

PART NUMBER SUMMARY / DIR NO:10004058813		
MATERIAL MASTER NO.	3D DIR	DESCRIPTION
PN-506749	10004683396	ASSY, MOT, 1M, AL RAILS, G4E-AC, ML (SHOWN)
PN-506753	10004683401	ASSY, MOT, 1M, AL RLS, SYNC, G4E-AC, ML

CRITICAL TO QUALITY CLASSIFICATION TABLE					
P=PERFORMANCE, F=FIT, A=ASSEMBLY X=IDENTIFIES APPLICABLE CLASSIFICATION(S) ◇=ENGINEERING AND/OR MANUFACTURING REQUIREMENT Ⓜ=REGULATORY REQUIREMENT-CONFORMANCE IS MANDATORY					
COMMENTS	DRAWING ZONE	P	F	A	R
ROHS	G1-HI				X

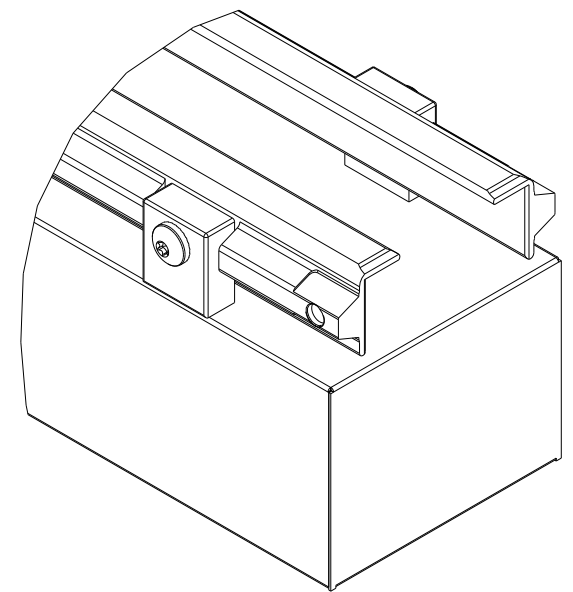
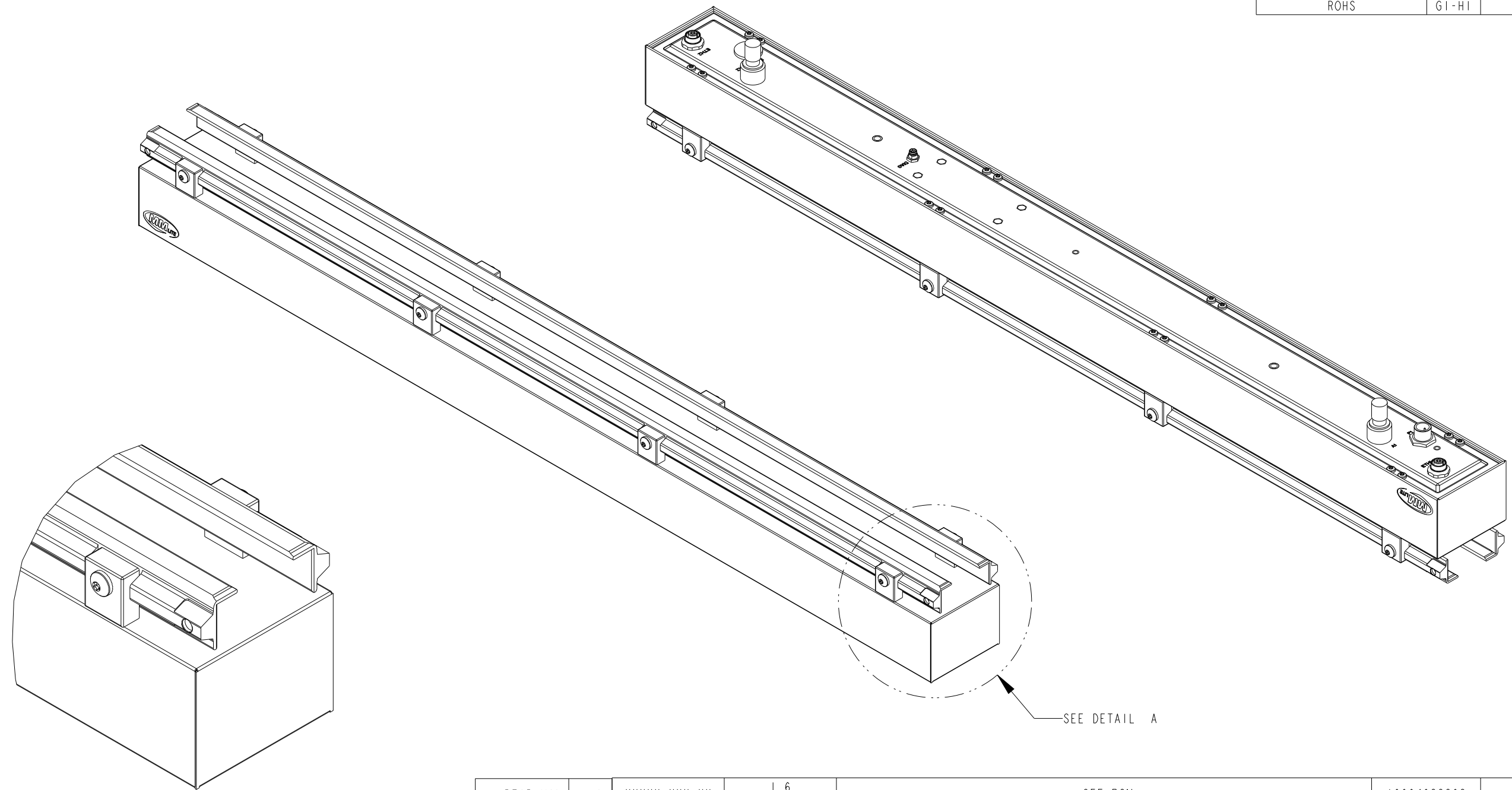

DETAIL A
SCALE 0.500

MUST COMPLY WITH ROCKWELL AUTOMATION ENVIRONMENTAL SPECIFICATION 970-20-01

- NOTES:
1. ALL DIMENSIONS ARE IN MM
 2. BREAK ALL SHARP EDGES
 3. CLEAN AND DEBURR
 4. USE MIN BEND RADII

J. PEARLMAN	1:4	XXXXX-XXX-XX	1.6	SEE BOM	10004683398	SEE TABLE		
ENGINEER	SCALE	WORKMANSHIP STANDARDS	FINISH	MATERIAL	MODEL/DIR NO.	PART/MMR NUMBER		
DIMENSION UNITS-mm		ALL UNDIMENSIONED GEOMETRIES ARE CONTROLLED BY THE CAD MODEL. IN CASE OF DIMENSION DISCREPANCY, CAD MODEL OVERRIDES.		Rockwell Automation		CONFIDENTIAL AND PROPRIETARY INFORMATION. THIS DOCUMENT CONTAINS CONFIDENTIAL AND PROPRIETARY INFORMATION OF ROCKWELL AUTOMATION, INC. AND MAY NOT BE USED, COPIED OR DISCLOSED TO OTHERS, EXCEPT WITH THE AUTHORIZED WRITTEN PERMISSION OF ROCKWELL AUTOMATION, INC.		
DIMENSIONS APPLY BEFORE SURFACE TREATMENT.		UNSPECIFIED TOLERANCES ARE AS FOLLOWS: X.XX ±0.13 X.X ±0.25 X. ±0.5 DEG ±0.5° TORQUE ±25%						
THIRD ANGLE PROJECTION		DESCRIPTION		DATE: 2019-03-01		SHEET 1 OF 2		
		ICD, MOT, 1M, AL RAILS, G4E-AC, ML		SIZE	DIR	VER		
		CREATED BY: ABHAYAR		CHANGED BY: *****		B	10004058813	01

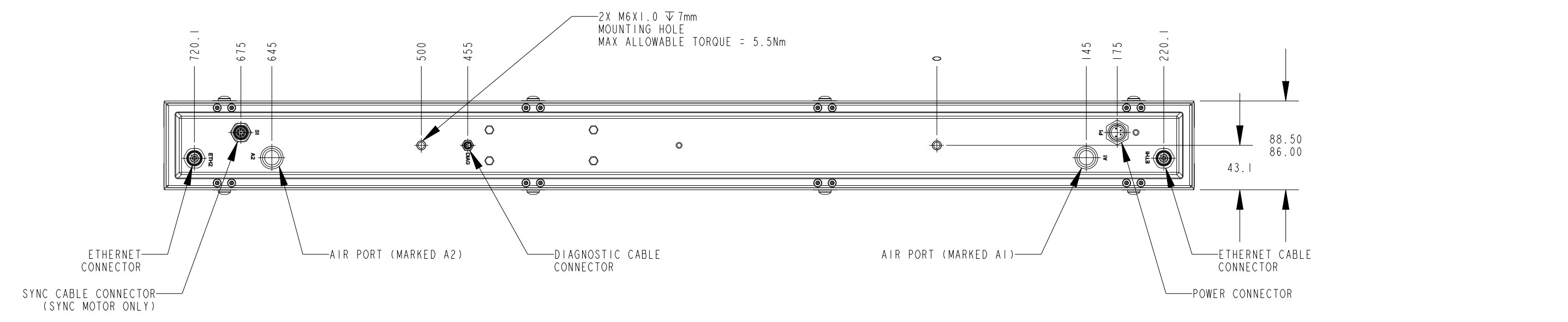
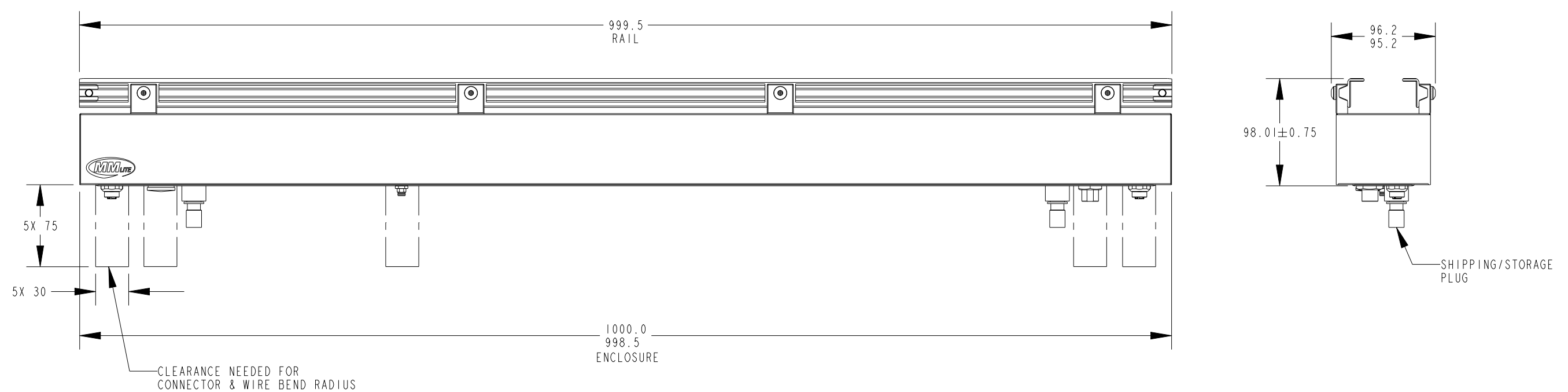

Rockwell Automation		CONFIDENTIAL AND PROPRIETARY INFORMATION. THIS DOCUMENT CONTAINS CONFIDENTIAL AND PROPRIETARY INFORMATION OF ROCKWELL AUTOMATION, INC. AND MAY NOT BE USED, COPIED OR DISCLOSED TO OTHERS, EXCEPT WITH THE AUTHORIZED WRITTEN PERMISSION OF ROCKWELL AUTOMATION, INC.	
DESCRIPTION ICD, MOT, 1M, AL RAILS, G4E-AC, ML		DATE: 2019-03-01	SHEET 2 OF 2
		SIZE B	DIR 10004058813
CREATED BY: ABHAYAR	CHANGED BY: *****	VER 01	