

PART NUMBER SUMMARY		
MATERIAL MASTER NO.	3D DIR	DESCRIPTION
700-1708-21	10004325033	ASSY, MOTOR, 250MM, SS RAILS, GEN4, ML
700-1708-24	10004325039	ASSY, MOTOR, 250MM, SS RAILS, SYNC, GEN4, ML

CRITICAL TO QUALITY CLASSIFICATION TABLE					
P=PERFORMANCE, F=FIT, A=ASSEMBLY X=IDENTIFIES APPLICABLE CLASSIFICATION(S) ◇=ENGINEERING AND/OR MANUFACTURING REQUIREMENT Ⓜ=REGULATORY REQUIREMENT-CONFORMANCE IS MANDATORY					
COMMENTS	DRAWING ZONE	P	F	A	R
ROHS	G1-HI				X

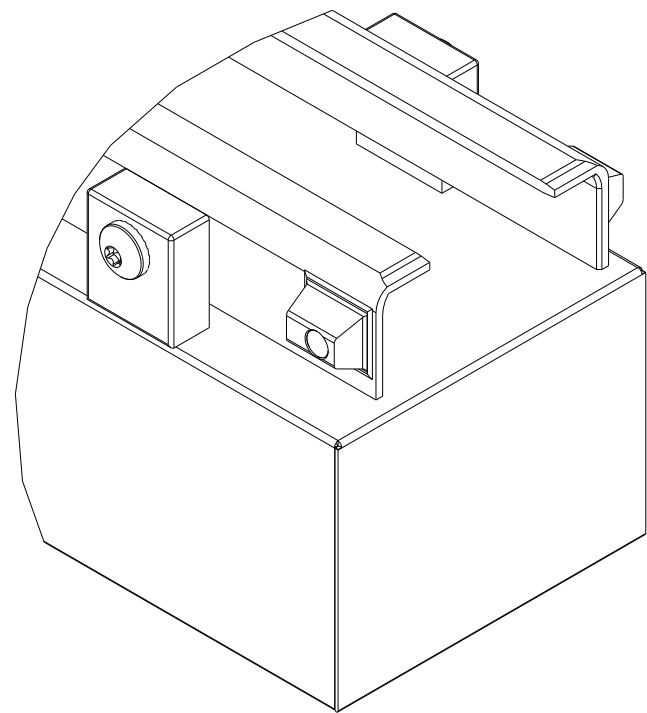

DETAIL A  
SCALE 0.667

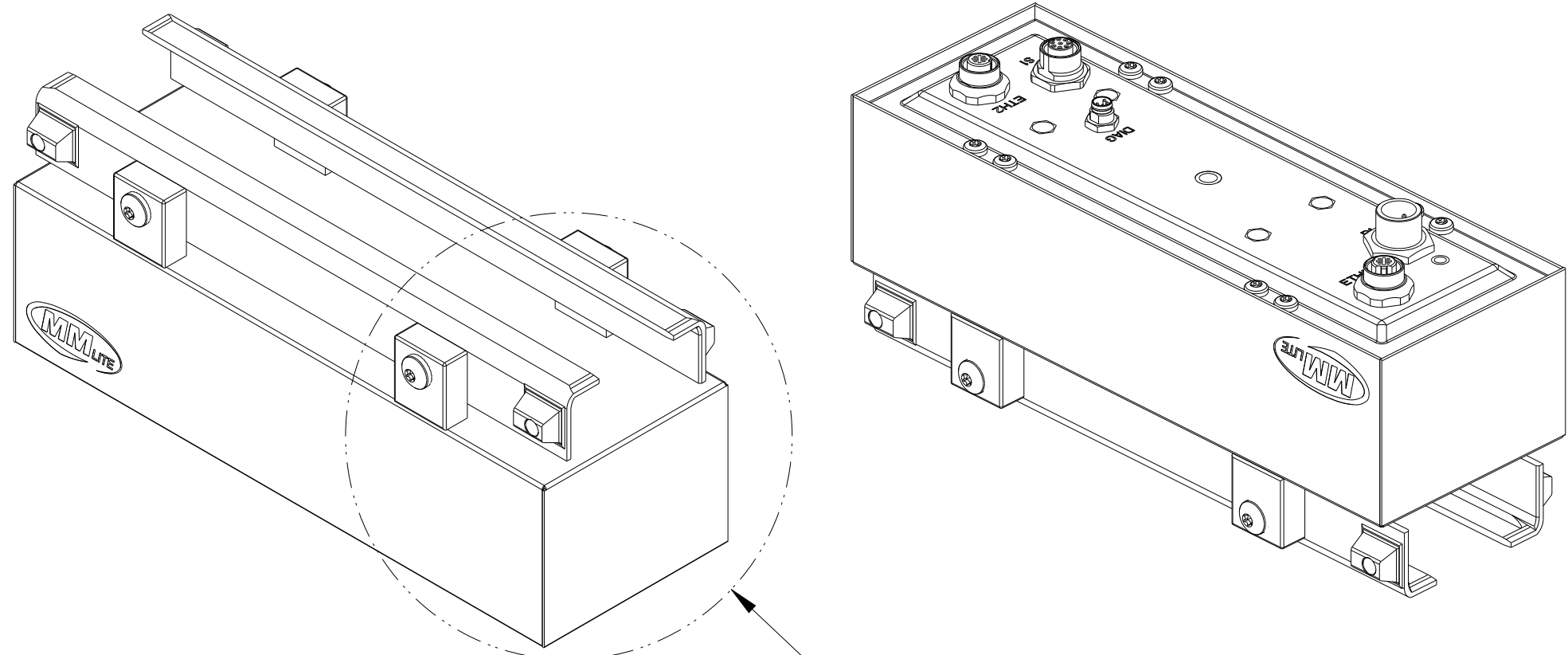

SEE DETAIL A

MUST COMPLY WITH ROCKWELL  
 AUTOMATION ENVIRONMENTAL  
 SPECIFICATION 970-20-01

E. GARDNER	1:2	XXXXX-XXX-XX	1.6	SEE BOM	10004325039	SEE TABLE
ENGINEER	SCALE	WORKMANSHIP STANDARDS	FINISH	MATERIAL	MODEL/DIR NO.	PART/MMR NUMBER
DIMENSION UNITS-mm <del>DIMENSIONS APPLY BEFORE SURFACE TREATMENT.</del> UNSPECIFIED TOLERANCES ARE AS FOLLOWS: X.XX ±0.13 X.X ±0.25 X. ±0.5 DEG ±0.5° TORQUE ±25%		ALL UNDIMENSIONED GEOMETRIES ARE CONTROLLED BY THE CAD MODEL. IN CASE OF DIMENSION DISCREPANCY, CAD MODEL OVERRIDES. THIRD ANGLE PROJECTION				CONFIDENTIAL AND PROPRIETARY INFORMATION. THIS DOCUMENT CONTAINS CONFIDENTIAL AND PROPRIETARY INFORMATION OF ROCKWELL AUTOMATION, INC. AND MAY NOT BE USED, COPIED OR DISCLOSED TO OTHERS, EXCEPT WITH THE AUTHORIZED WRITTEN PERMISSION OF ROCKWELL AUTOMATION, INC.
DESCRIPTION				ICD, MOTOR, 250MM, SS RAILS, G4E, ML		DATE: 2018-10-03
CREATED BY: ABHAYAR				CHANGED BY: *****		SHEET 1 OF 2
SIZE		DIR		VER		
B		10004342362		00		

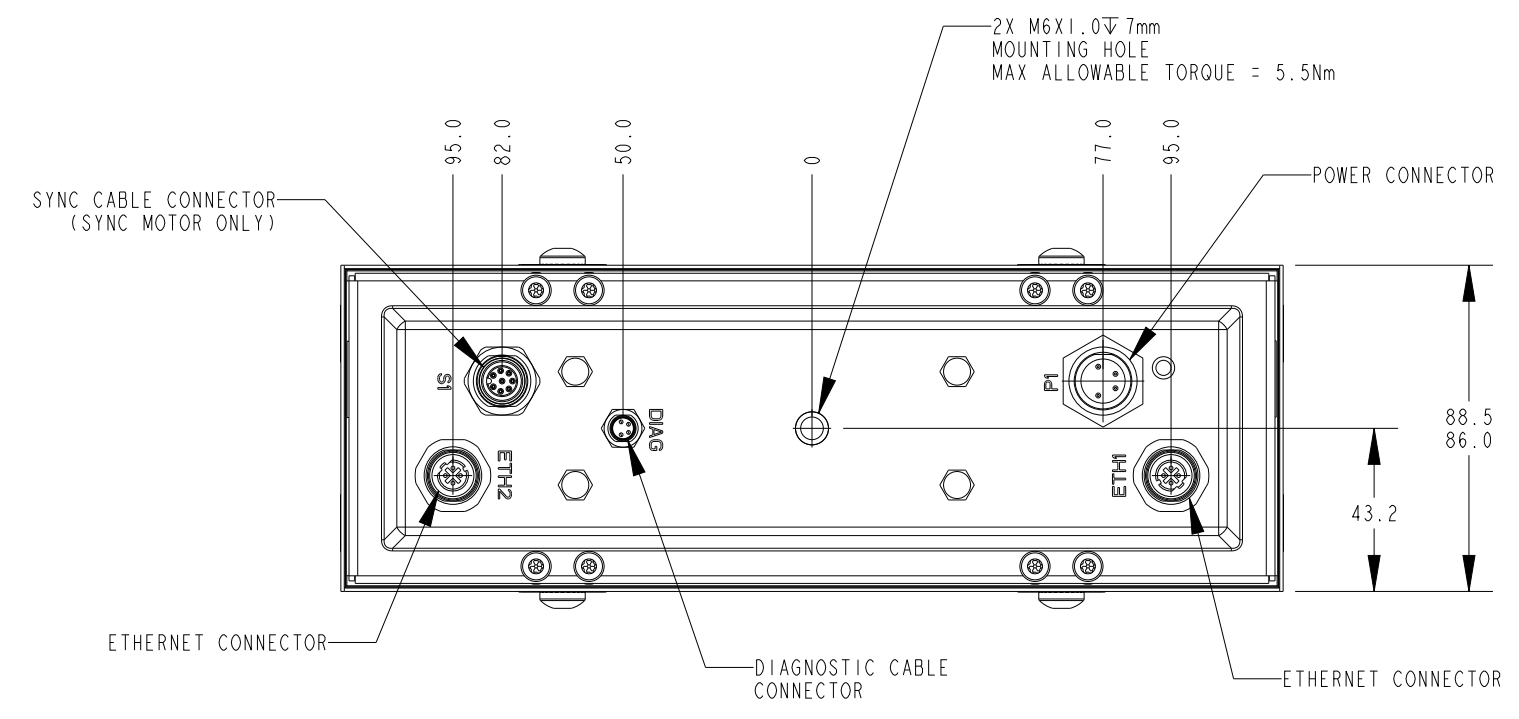
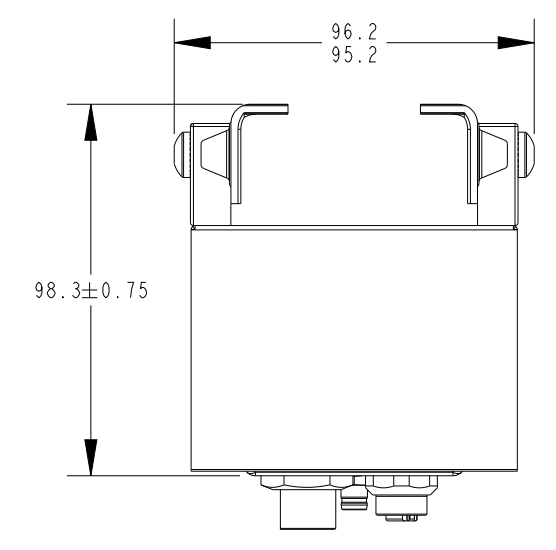
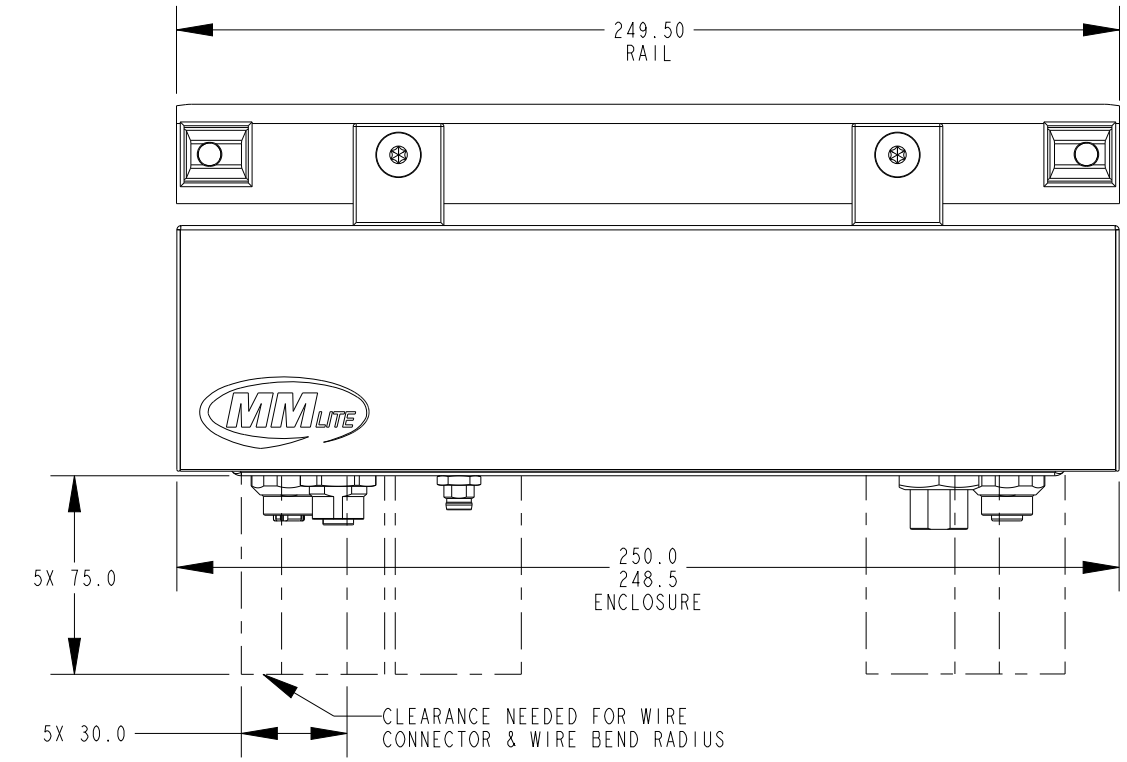

<p style="text-align: center;"><b>Rockwell Automation</b></p>		<p style="text-align: center;">CONFIDENTIAL AND PROPRIETARY INFORMATION. THIS DOCUMENT CONTAINS CONFIDENTIAL AND PROPRIETARY INFORMATION OF ROCKWELL AUTOMATION, INC. AND MAY NOT BE USED, COPIED OR DISCLOSED TO OTHERS, EXCEPT WITH THE AUTHORIZED WRITTEN PERMISSION OF ROCKWELL AUTOMATION, INC.</p>			
		DATE: 2018-10-03	SHEET 2 OF 2		
DESCRIPTION	ICD, MOTOR, 250MM, SS RAILS, G4E, ML		SIZE	DIR	VER
	CREATED BY: ABHAYAR	CHANGED BY: *****	<b>B</b>	<b>10004342362</b>	<b>00</b>