

1 2 3 4 5 6 7 8

A
B
C
D
E
F
G
H

CRITICAL TO QUALITY CLASSIFICATION TABLE					
P=PERFORMANCE, F=FIT, A=ASSEMBLY					
X=IDENTIFIES APPLICABLE CLASSIFICATION(S)					
⊕ENGINEERING AND/OR MANUFACTURING REQUIREMENT					
⊕REGULATORY REQUIREMENT-CONFORMANCE IS MANDATORY					
COMMENTS	DRAWING ZONE	P	F	A	R
ROHS	G1-H1				X

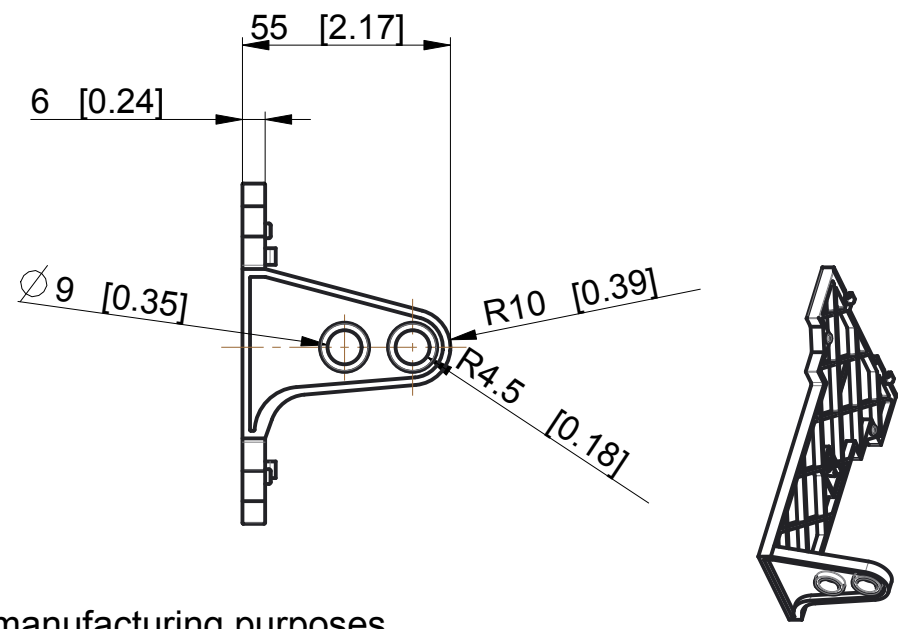
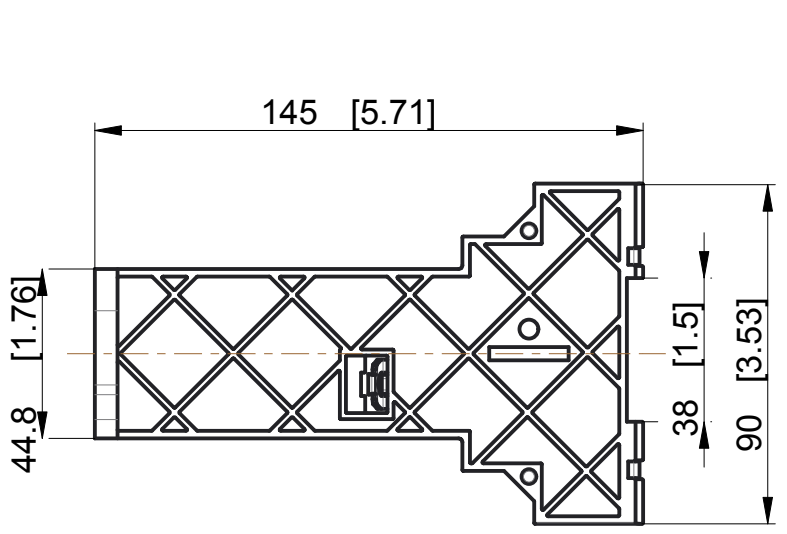

-Dimensions are shown in mm [inches]
 -Dimensions are not intended to be used for manufacturing purposes

			10004753987	PN-527900
WORKMANSHIP STANDARDS	FINISH	MATERIAL	MODEL/DIR NO.	PART/MMR NUMBER
ALL UNDIMENSIONED GEOMETRIES ARE CONTROLLED BY THE CAD MODEL. IN CASE OF DIMENSION DISCREPANCY, CAD MODEL OVERRIDES.			CONFIDENTIAL AND PROPRIETARY INFORMATION. THIS DOCUMENT CONTAINS CONFIDENTIAL AND PROPRIETARY INFORMATION OF ROCKWELL AUTOMATION, INC. AND MAY NOT BE USED, COPIED OR DISCLOSED TO OTHERS, EXCEPT WITH THE AUTHORIZED WRITTEN PERMISSION OF ROCKWELL AUTOMATION, INC.	
	140MP-A-SHS	CREATED BY:C.Gloor	CHANGED BY:C.Gloor	SIZE: A4 DIR: 10004753988 VER: 00

MUST COMPLY WITH ROCKWELL AUTOMATION ENVIRONMENTAL SPECIFICATION 970-20-01

1 2 3 4 5 6 7 8