

1 2 3 4 5 6 7 8

A
B
C
D
E
F
G
H

CRITICAL TO QUALITY CLASSIFICATION TABLE					
P=PERFORMANCE, F=FIT, A=ASSEMBLY					
X=IDENTIFIES APPLICABLE CLASSIFICATION(S)					
⊕ENGINEERING AND/OR MANUFACTURING REQUIREMENT					
⊕REGULATORY REQUIREMENT-CONFORMANCE IS MANDATORY					
COMMENTS	DRAWING ZONE	P	F	A	R
ROHS	F1-G1				X

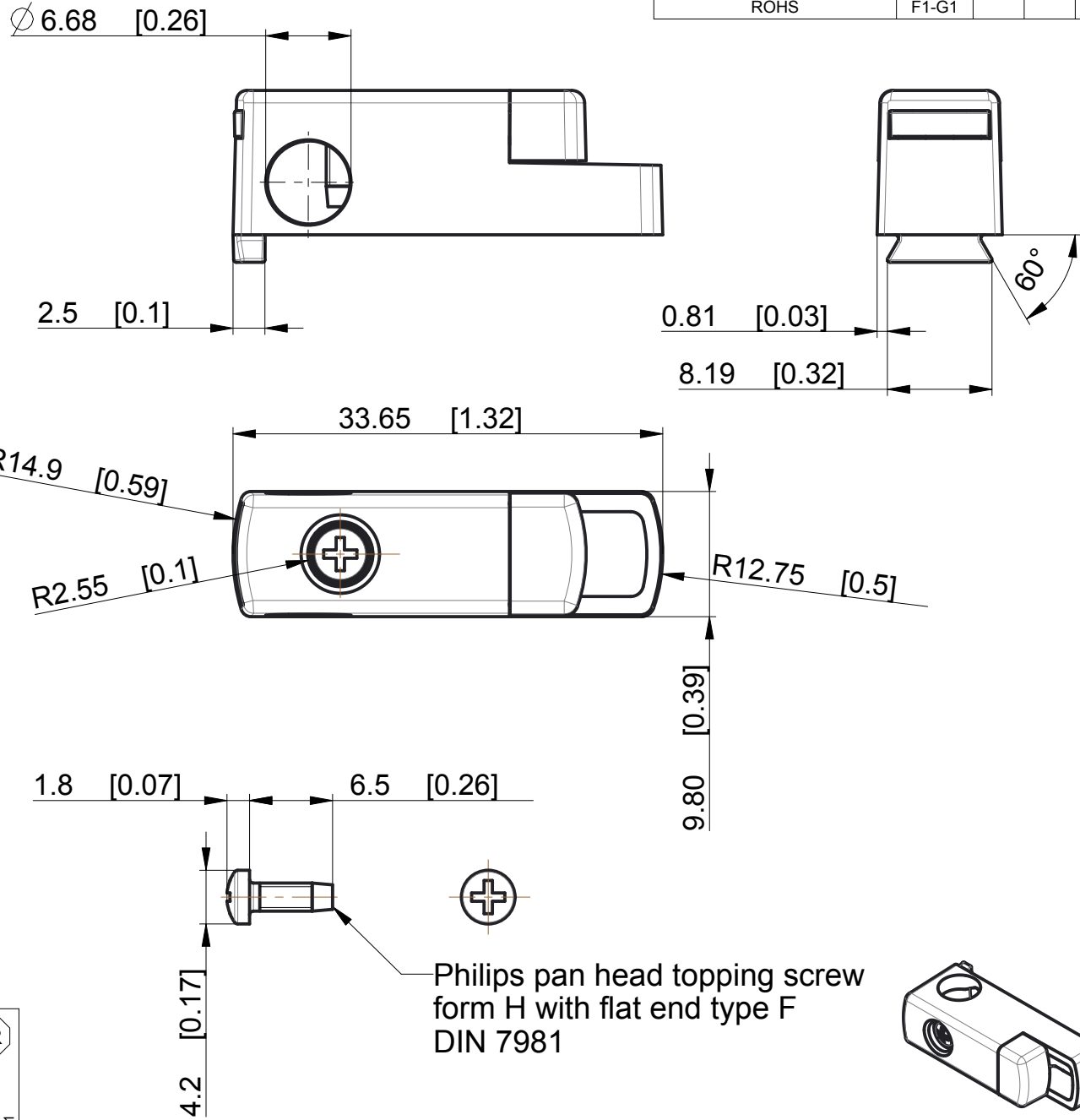

-Dimensions are shown in mm [inches]
 -Dimensions are not intended to be used for manufacturing purposes

MUST COMPLY WITH ROCKWELL AUTOMATION ENVIRONMENTAL SPECIFICATION 970-20-01

			10004827001	PN-527888
WORKMANSHIP STANDARDS	FINISH	MATERIAL	MODEL/DIR NO.	PART/MMR NUMBER

Rockwell Automation

CONFIDENTIAL AND PROPRIETARY INFORMATION. THIS DOCUMENT CONTAINS CONFIDENTIAL AND PROPRIETARY INFORMATION OF ROCKWELL AUTOMATION, INC. AND MAY NOT BE USED, COPIED OR DISCLOSED TO OTHERS, EXCEPT WITH THE AUTHORIZED WRITTEN PERMISSION OF ROCKWELL AUTOMATION, INC.

DESCRIPTION	140MP-A-KN1		DATE:2019-05-27		SHEET 1 OF 1	
	CREATED BY:C.Gloor	CHANGED BY:C.Gloor	SIZE	DIR	VER	
			A4	10004827002		00

1 2 3 4 5 6 7 8