

CRITICAL TO QUALITY CLASSIFICATION TABLE

P=PERFORMANCE, F=FIT, A=ASSEMBLY
 X=IDENTIFIES APPLICABLE CLASSIFICATION(S)
 ◇=ENGINEERING AND/OR MANUFACTURING REQUIREMENT
 ⊕=REGULATORY REQUIREMENT-CONFORMANCE IS MANDATORY

COMMENTS	DRAWING ZONE	P	F	A	R
ROHS	G1-H1				X

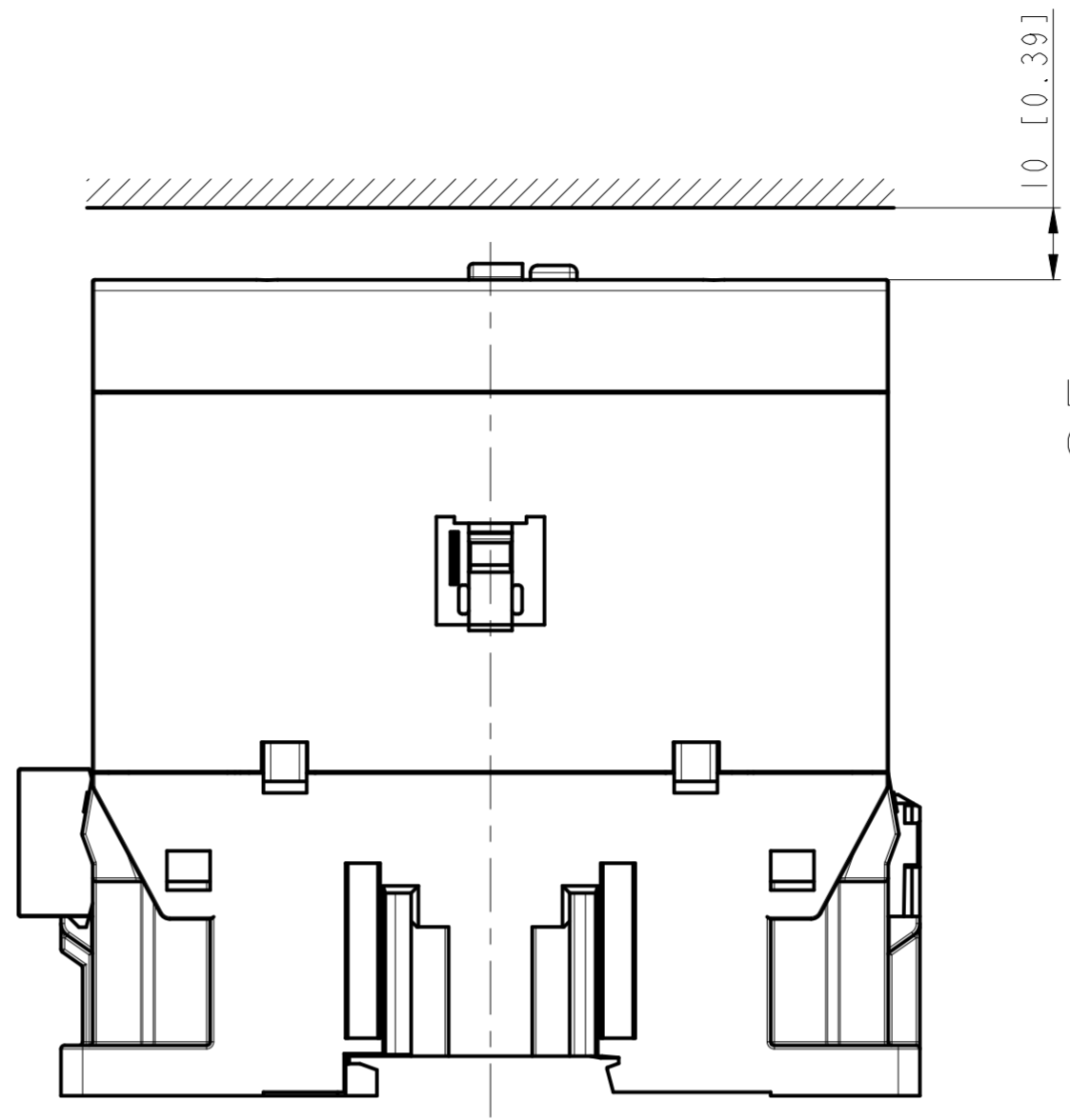
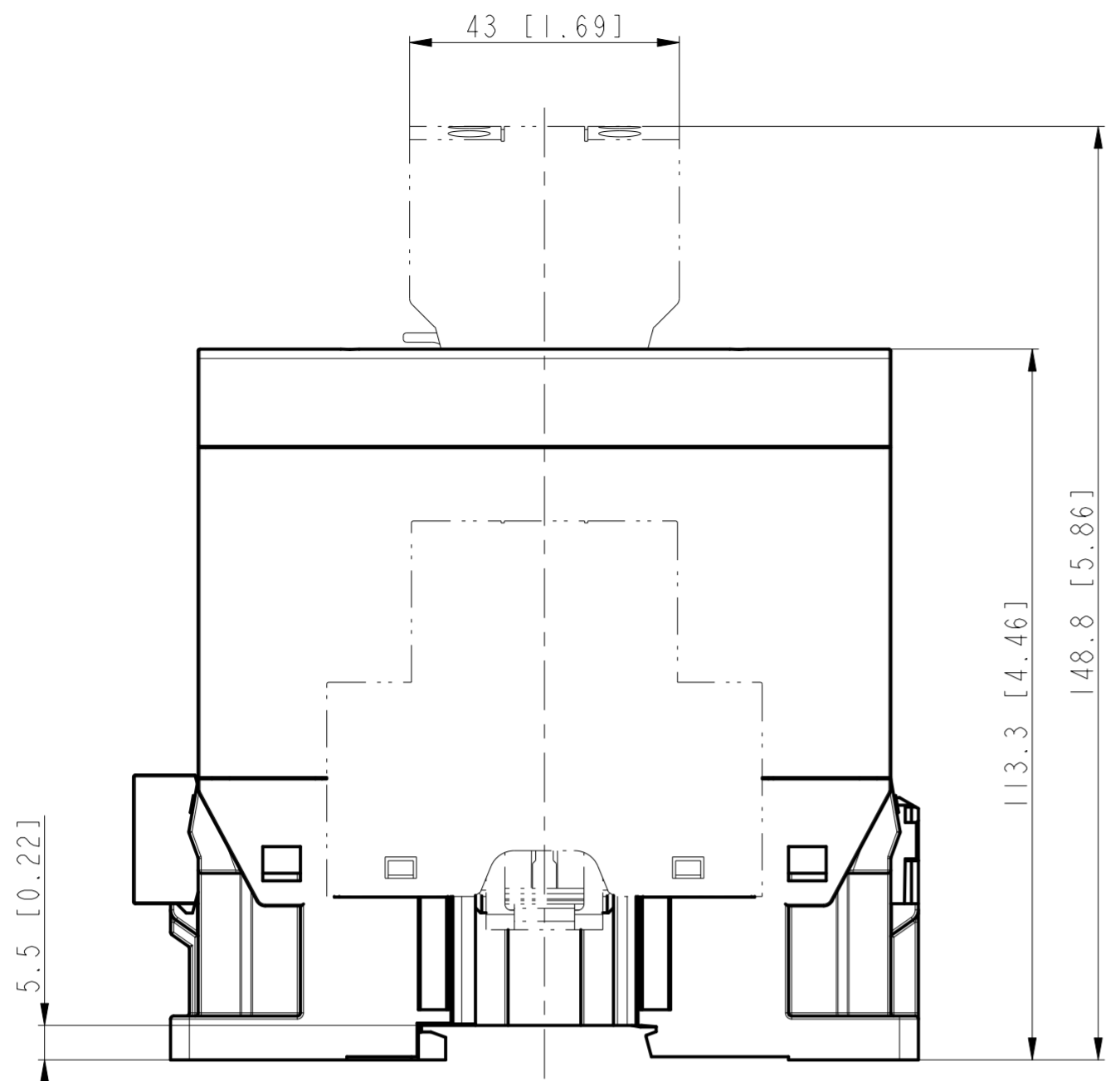

Lateral distance to grounded components
 0 mm [0"] allowed.

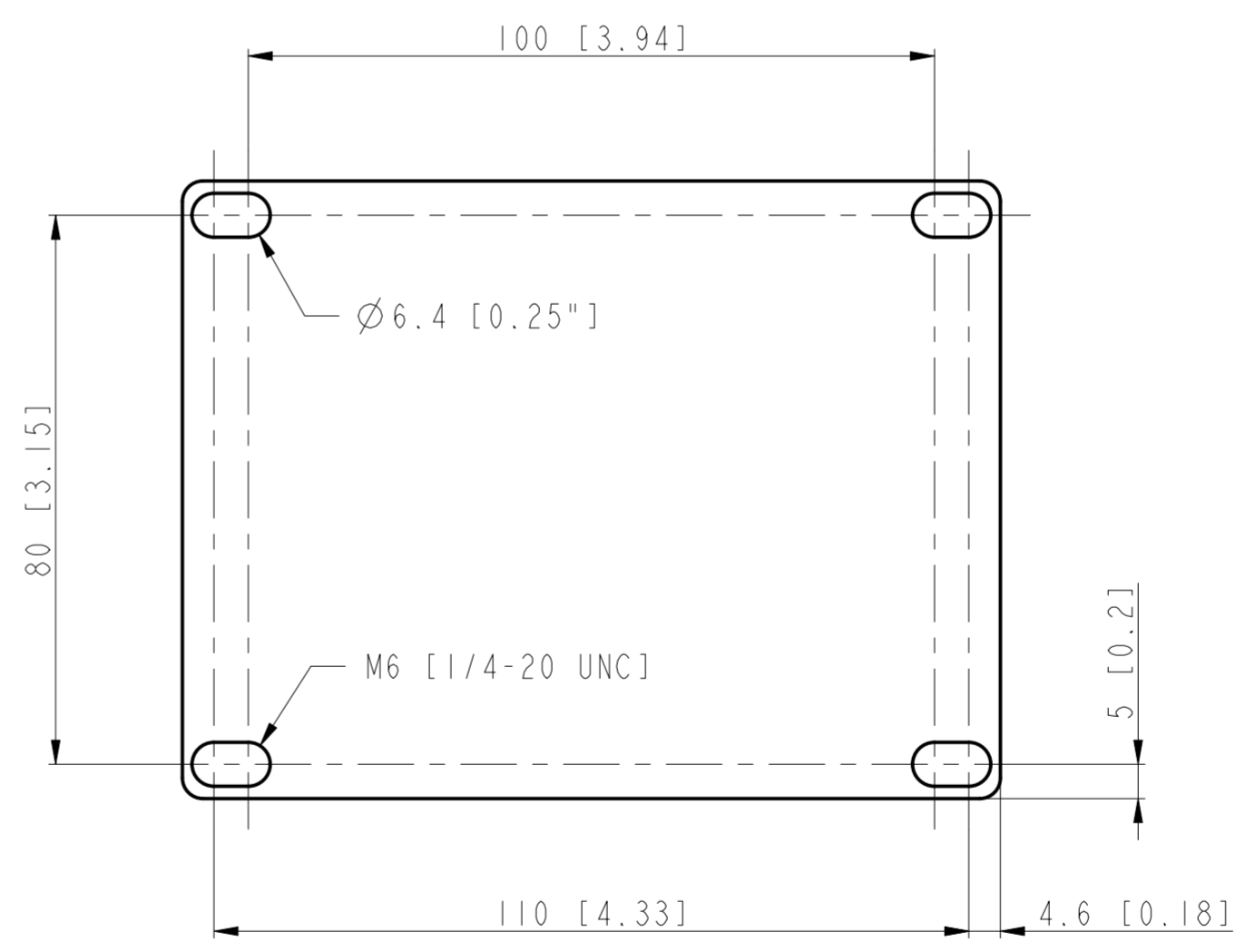
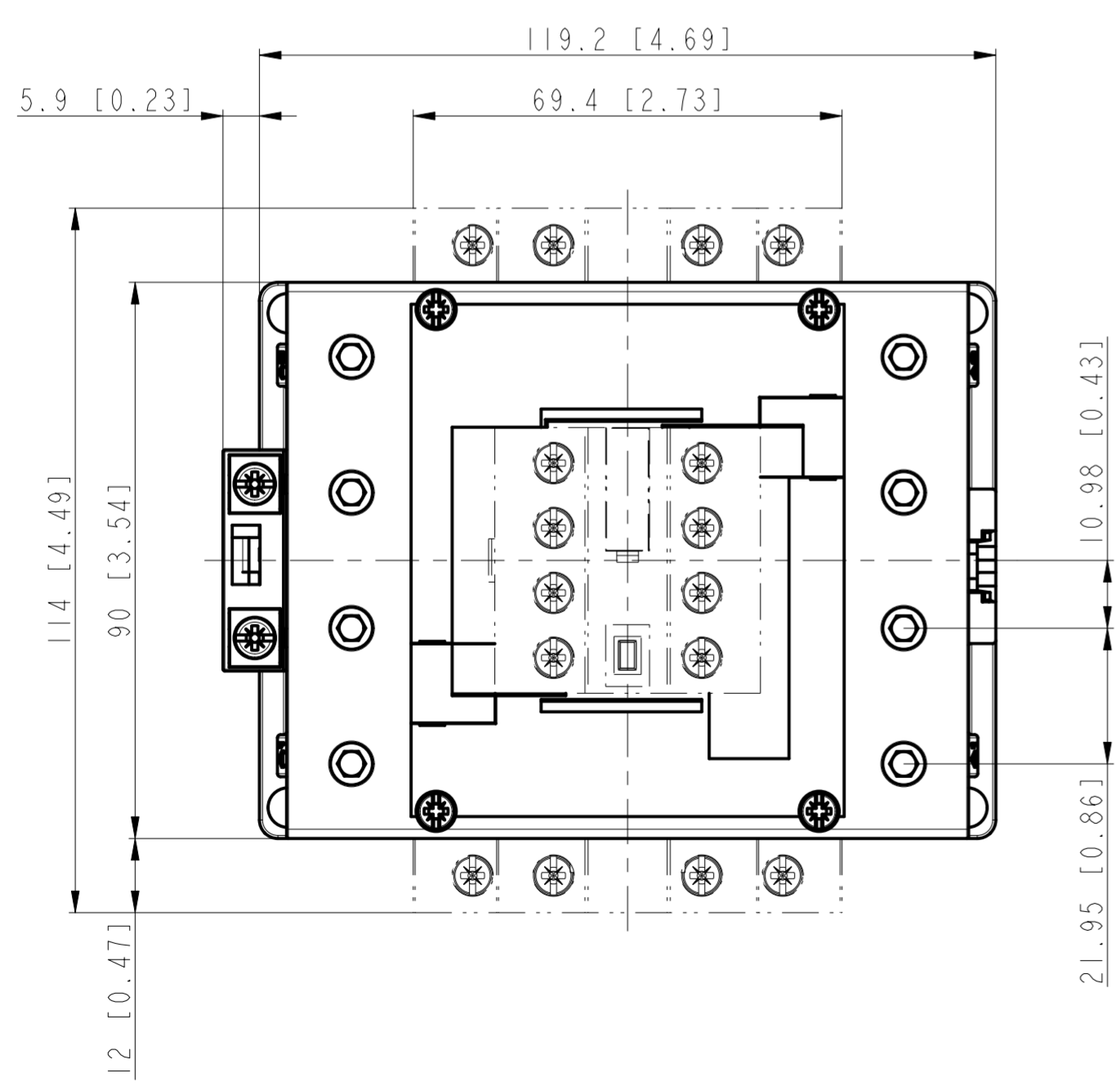

- Dimensions are shown in mm [inches]
 - Dimensions are not intended to be used for manufacturing purposes

MUST COMPLY WITH ROCKWELL AUTOMATION ENVIRONMENTAL SPECIFICATION 970-20-01

WORKMANSHIP STANDARDS	FINISH	MATERIAL	MODEL/DIR NO.	PART/MMR NUMBER
ALL UNDIMENSIONED GEOMETRIES ARE CONTROLLED BY THE CAD MODEL. IN CASE OF DIMENSION DISCREPANCY, CAD MODEL OVERRIDES.			10004760572	PN-525816 PN-525817 PN-525818 PN-525819
FIRST ANGLE PROJECTION			DATE: 2020-08-31	SHEET 1 OF 1
DESCRIPTION	300-DO*9400,4-pol,100-ES*/-EF*		SIZE DIR	VER
CREATED BY: uweber	CHANGED BY: uweber		A2	10005750083
				00

CONFIDENTIAL AND PROPRIETARY INFORMATION. THIS DOCUMENT CONTAINS CONFIDENTIAL AND PROPRIETARY INFORMATION OF ROCKWELL AUTOMATION, INC. AND MAY NOT BE USED, COPIED OR DISCLOSED TO OTHERS, EXCEPT WITH THE AUTHORIZED WRITTEN PERMISSION OF ROCKWELL AUTOMATION, INC.

