

CRITICAL TO QUALITY CLASSIFICATION TABLE					
P=PERFORMANCE, F=FIT, A=ASSEMBLY					
X=IDENTIFIES APPLICABLE CLASSIFICATION(S)					
◇=ENGINEERING AND/OR MANUFACTURING REQUIREMENT					
Ⓡ=REGULATORY REQUIREMENT-CONFORMANCE IS MANDATORY					
COMMENTS	DRAWING ZONE	P	F	A	R
ROHS	GI-HI				X

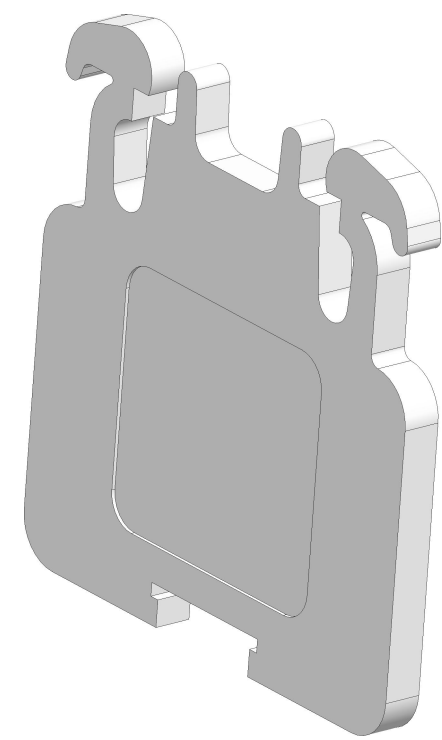
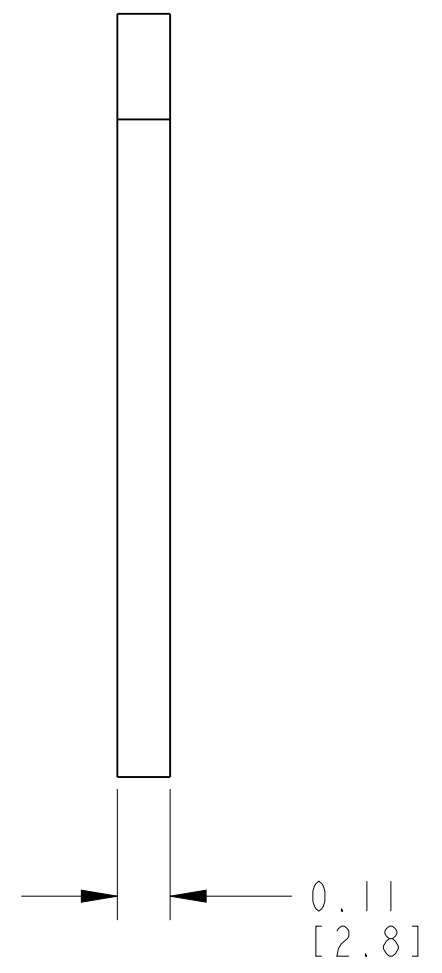
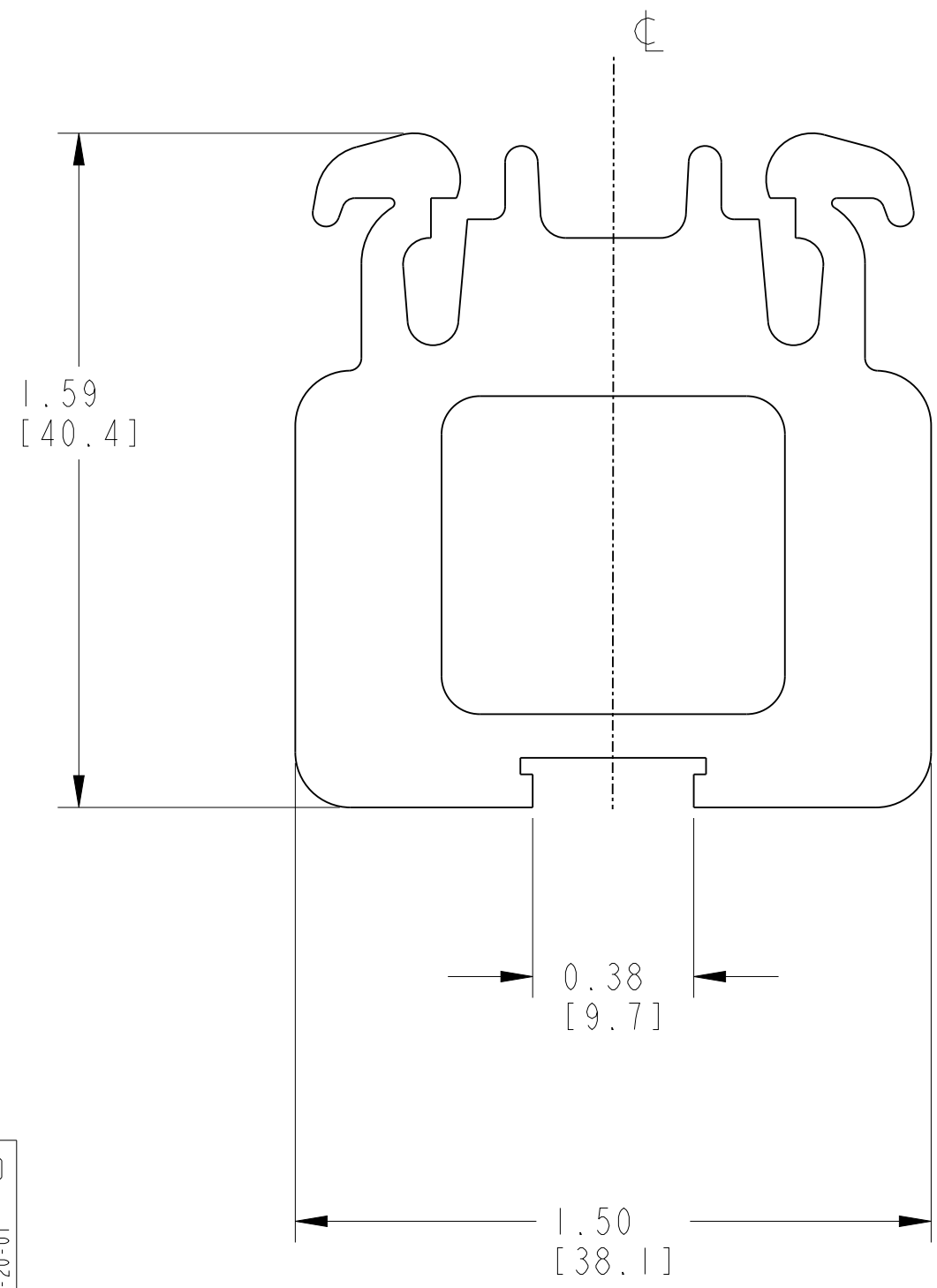

ISOMETRIC VIEW

NOTE:
DIMENSIONS ARE SHOWN IN INCHES [MILLIMETERS]
DIMENSIONS ARE NOT INTENDED TO USE FOR MANUFACTURING PURPOSE

MUST COMPLY WITH ROCKWELL AUTOMATION ENVIRONMENTAL SPECIFICATION 970-20-01



ALL UNDIMENSIONED GEOMETRIES ARE CONTROLLED BY THE CAD MODEL. IN CASE OF DIMENSION DISCREPANCY, CAD MODEL OVERRIDES. THIRD ANGLE PROJECTION 			CONFIDENTIAL AND PROPRIETARY INFORMATION. THIS DOCUMENT CONTAINS CONFIDENTIAL AND PROPRIETARY INFORMATION OF ROCKWELL AUTOMATION, INC. AND MAY NOT BE USED, COPIED OR DISCLOSED TO OTHERS, EXCEPT WITH THE AUTHORIZED WRITTEN PERMISSION OF ROCKWELL AUTOMATION, INC.	
			CUSTOMER DRAWING 1492-N16	
DESCRIPTION CREATED BY: BSOMAYAJI	CHANGED BY: -	SIZE B	DIR 10007238460	VER 00