

CRITICAL TO QUALITY CLASSIFICATION TABLE
P=PERFORMANCE, F=FIT, A=ASSEMBLY
X=IDENTIFIES APPLICABLE CLASSIFICATION(S)
⊕=ENGINEERING AND/OR MANUFACTURING REQUIREMENT
Ⓢ=REGULATORY REQUIREMENT-CONFORMANCE IS MANDATORY

COMMENTS	DRAWING ZONE	P	F	A	R
ROHS	G1-H1				X

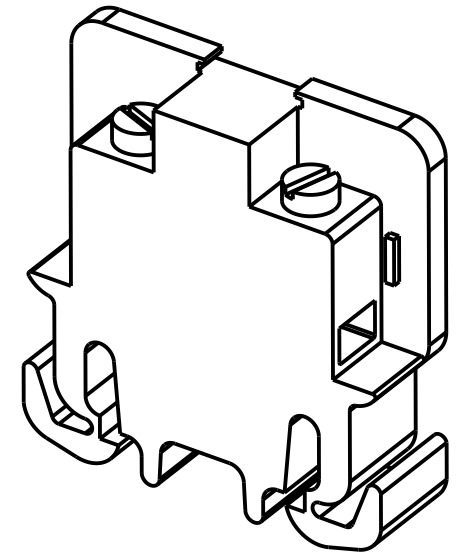
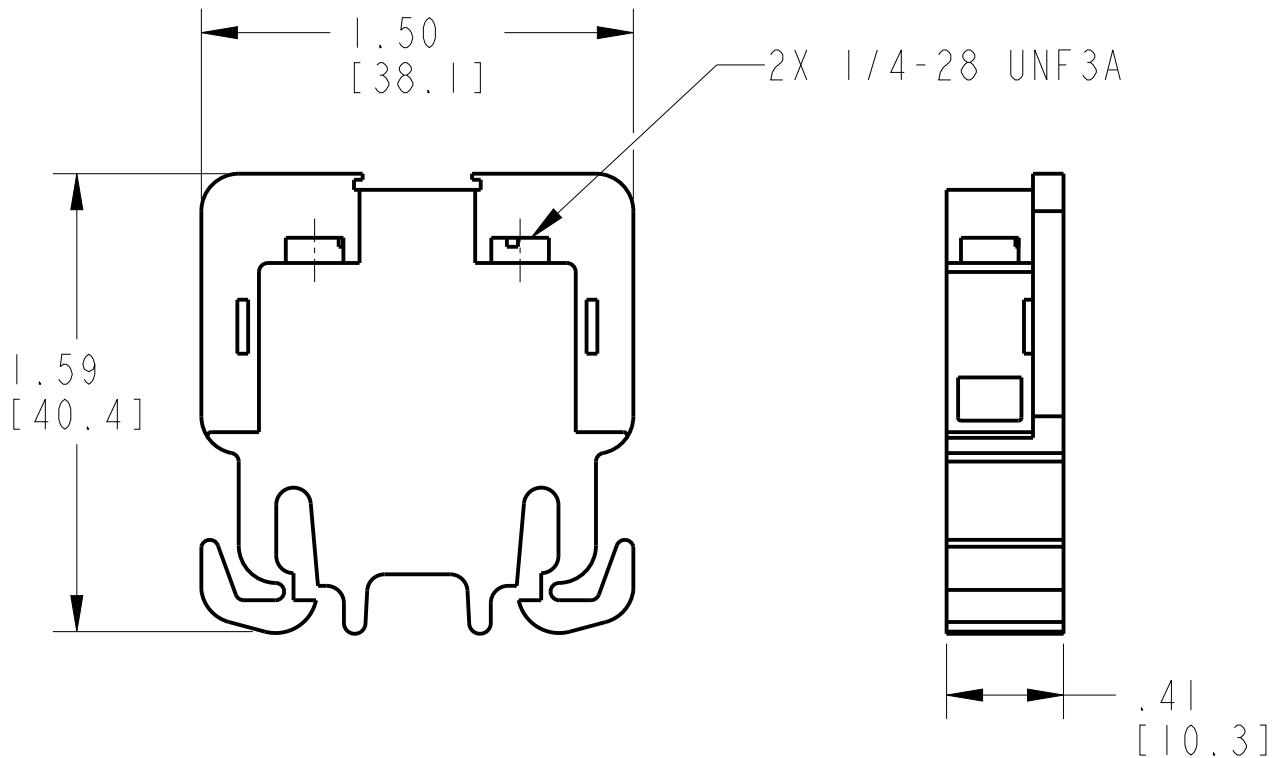

ISOMETRIC VIEW

NOTE:
1. APPROXIMATE DIMENSIONS ARE SHOWN IN INCHES [MILLIMETERS].
DIMENSIONS ARE NOT INTENDED TO BE USED FOR MANUFACTURING PURPOSES.

MUST COMPLY WITH ROCKWELL AUTOMATION ENVIRONMENTAL SPECIFICATION 970-20-01



ALL UNDIMENSIONED GEOMETRIES ARE CONTROLLED BY THE CAD MODEL. IN CASE OF DIMENSION DISCREPANCY, CAD MODEL OVERRIDES.



Rockwell Automation

CONFIDENTIAL AND PROPRIETARY INFORMATION. THIS DOCUMENT CONTAINS CONFIDENTIAL AND PROPRIETARY INFORMATION OF ROCKWELL AUTOMATION, INC. AND MAY NOT BE USED, COPIED OR DISCLOSED TO OTHERS, EXCEPT WITH THE AUTHORIZED WRITTEN PERMISSION OF ROCKWELL AUTOMATION, INC.

THIRD ANGLE PROJECTION

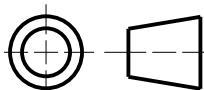

DESCRIPTION

1492-CA1
CUSTOMER DRAWING

DATE: 2023-07-28

SHEET 1 OF 1

SIZE

DIR

VER

A

10007517143

00

CREATED BY: AKHAN24

CHANGED BY: -