

CRITICAL TO QUALITY CLASSIFICATION TABLE					
P=PERFORMANCE, F=FIT, A=ASSEMBLY					
X=IDENTIFIES APPLICABLE CLASSIFICATION(S)					
◇=ENGINEERING AND/OR MANUFACTURING REQUIREMENT					
Ⓡ=REGULATORY REQUIREMENT-CONFORMANCE IS MANDATORY					
COMMENTS	DRAWING ZONE	◇ P	◇ F	◇ A	◇ R
ROHS	G-1				X

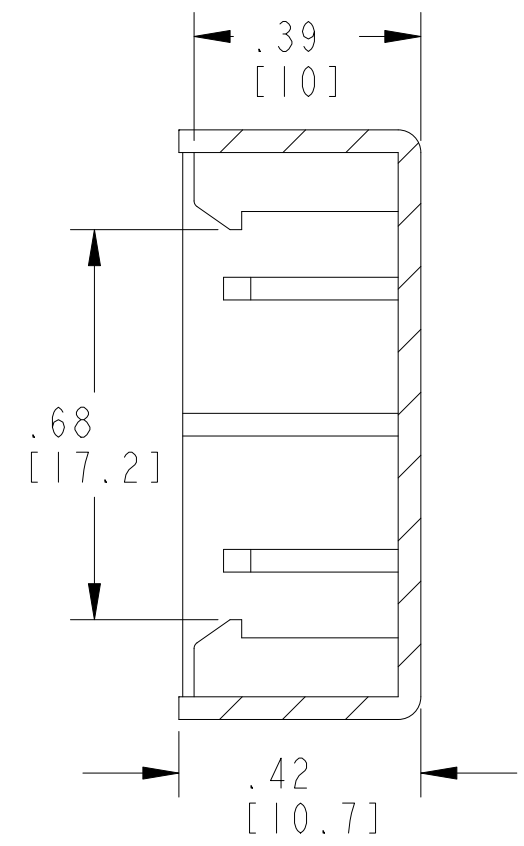

SECTION A-A

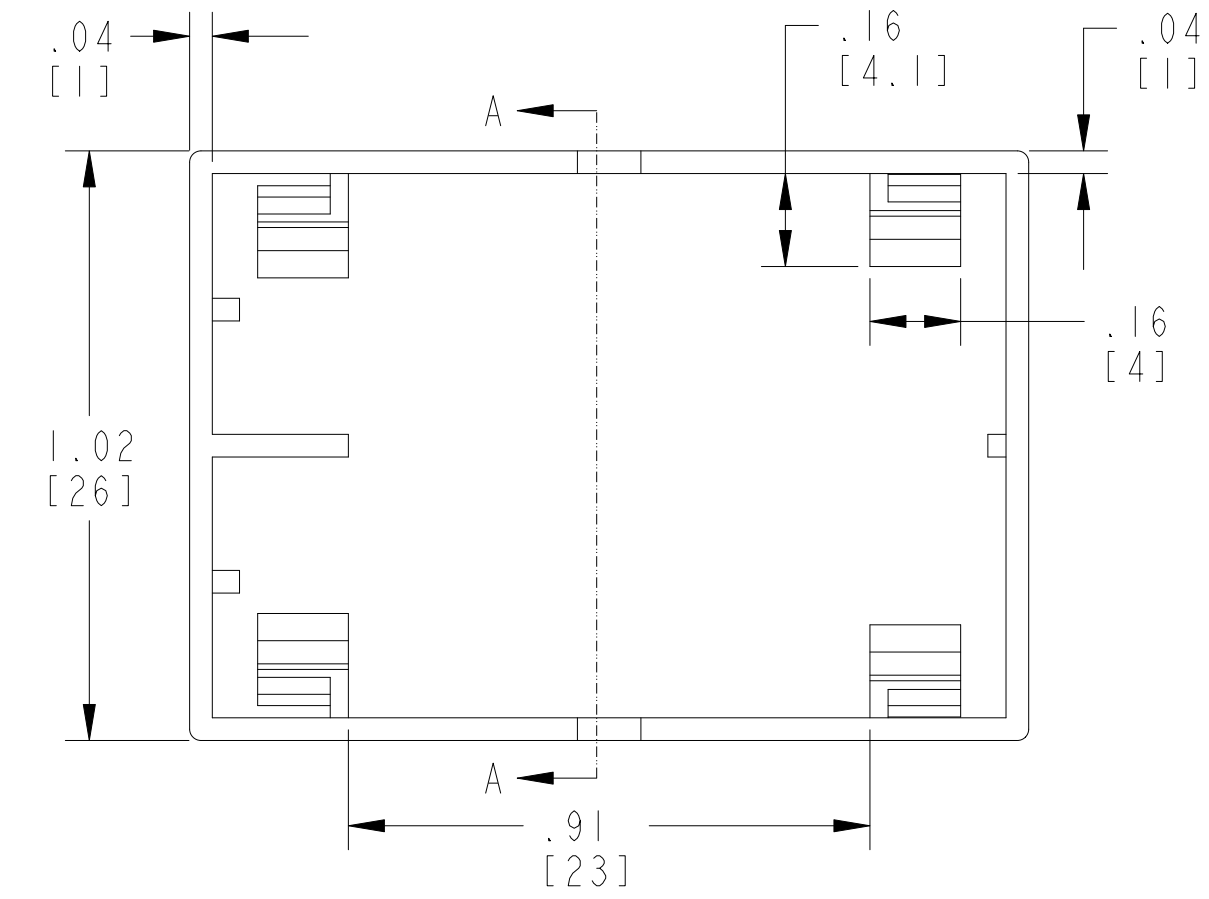
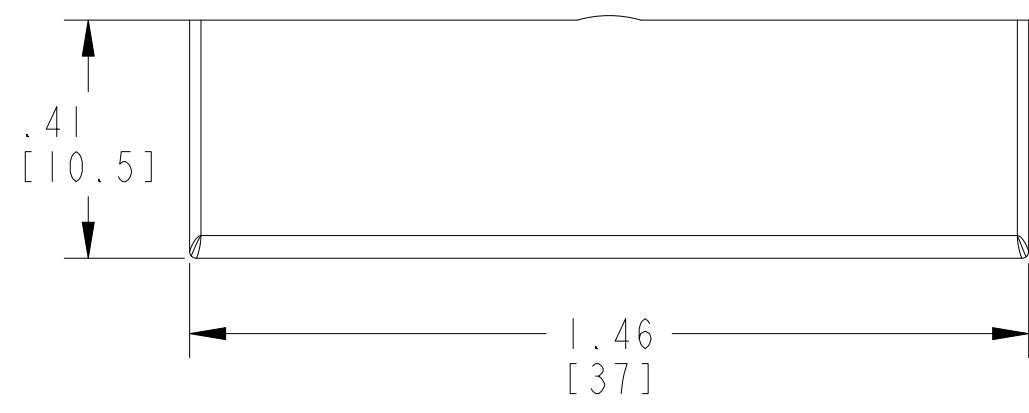
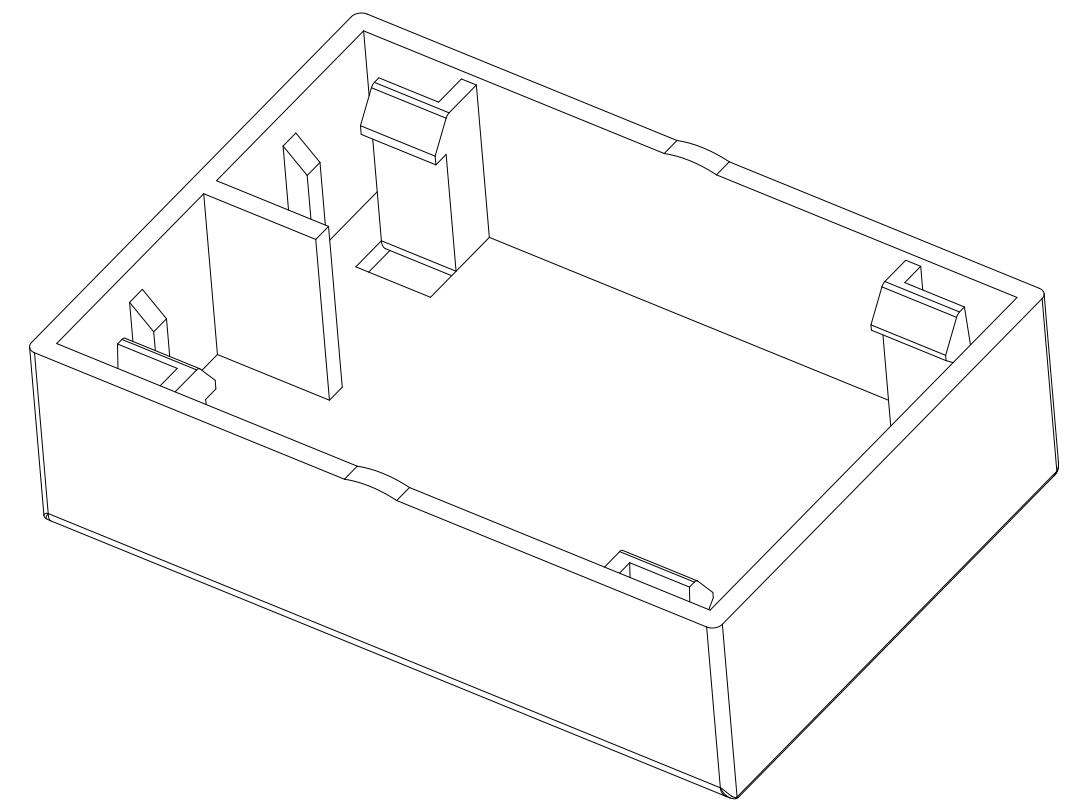

NOTE:
 1. APPROXIMATE DIMENSIONS ARE SHOWN IN INCHES [MILLIMETERS].
 DIMENSIONS ARE NOT INTENDED TO BE USED FOR MANUFACTURING PURPOSES.

MUST COMPLY WITH ROCKWELL AUTOMATION ENVIRONMENTAL SPECIFICATION 970-20-01



ALL UNDIMENSIONED GEOMETRIES ARE CONTROLLED BY THE CAD MODEL. IN CASE OF DIMENSION DISCREPANCY, CAD MODEL OVERRIDES.			CONFIDENTIAL AND PROPRIETARY INFORMATION. THIS DOCUMENT CONTAINS CONFIDENTIAL AND PROPRIETARY INFORMATION OF ROCKWELL AUTOMATION, INC. AND MAY NOT BE USED, COPIED OR DISCLOSED TO OTHERS, EXCEPT WITH THE AUTHORIZED WRITTEN PERMISSION OF ROCKWELL AUTOMATION, INC.		
	THIRD ANGLE PROJECTION 		100-SCC, PROTECTIVE CAP FOR CONTACTOR CUSTOMER DRAWING		DATE: 2024-03-28
DESCRIPTION		CREATED BY: AKHAN24		SHEET 1 OF 1	
CHANGED BY: -		SIZE: B	DIR: 10007888510		VER: 00