

1 2 3 4 5 6 7 8

A
B
C
D
E
F
G
H

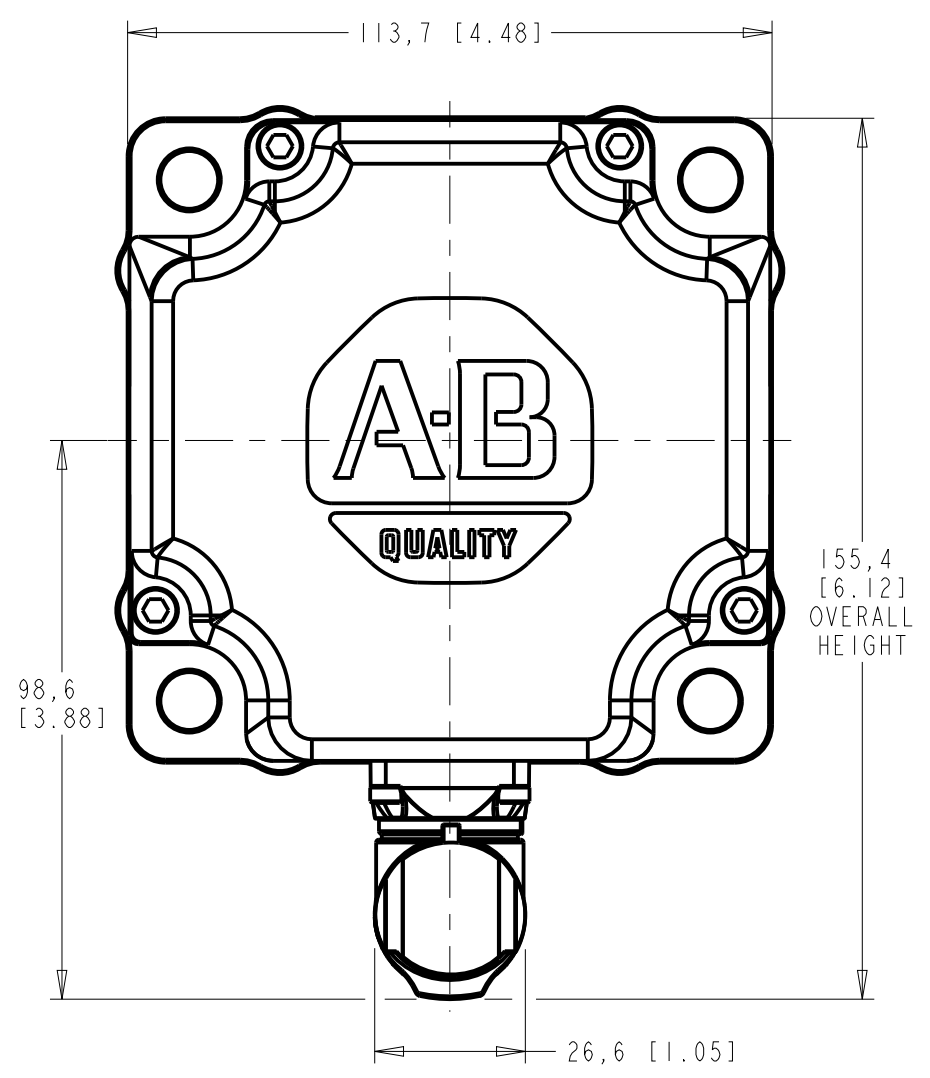

CONNECTOR HOUSING MAY BE ROTATED FOR REARWARD CONNECTOR ORIENTATION

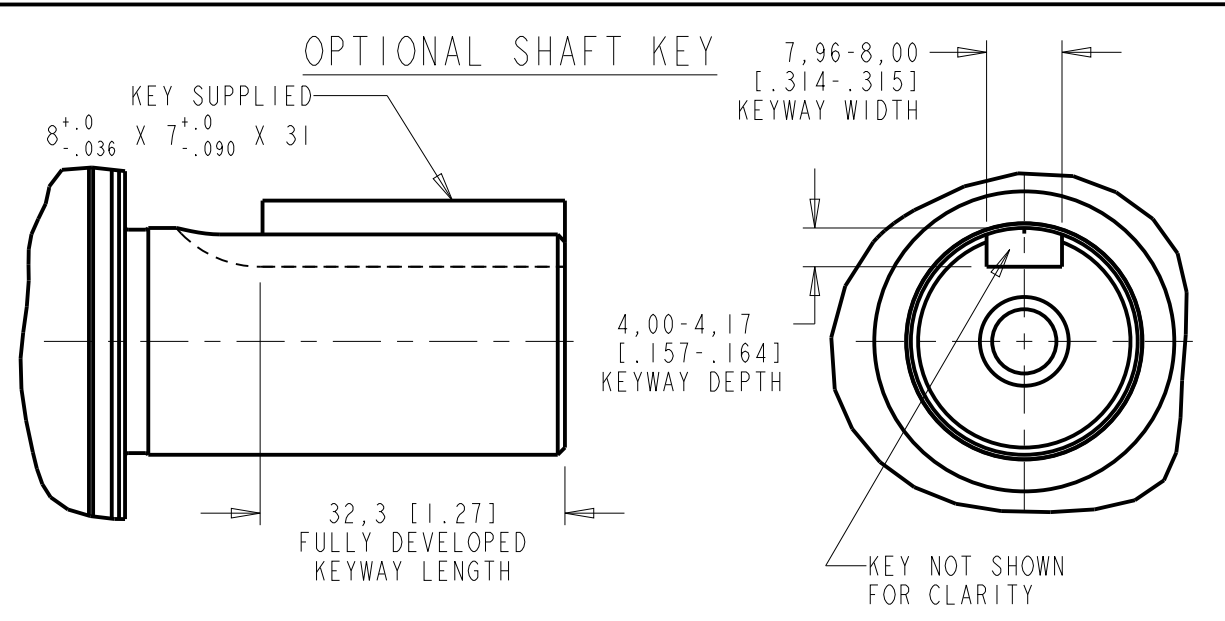
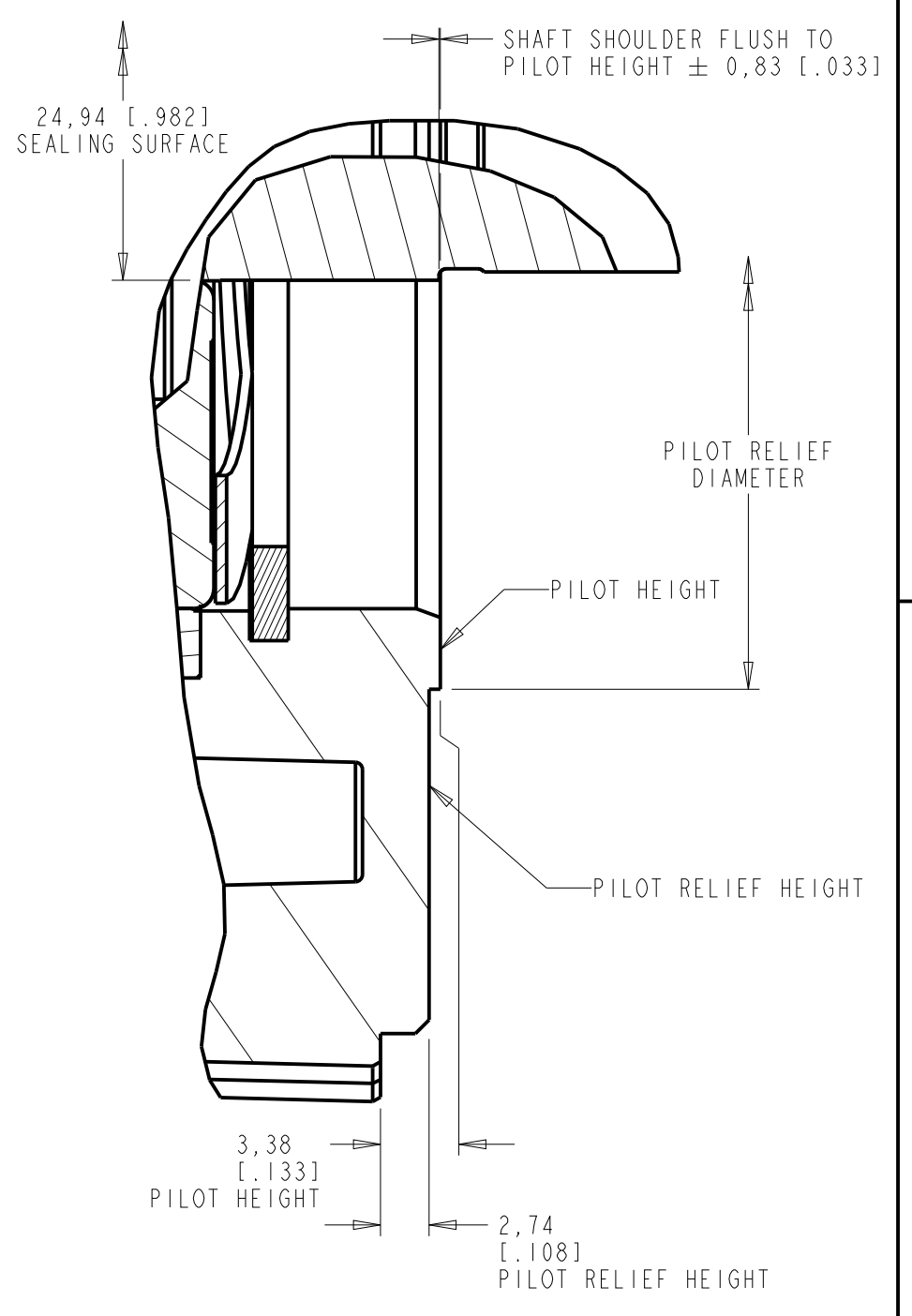
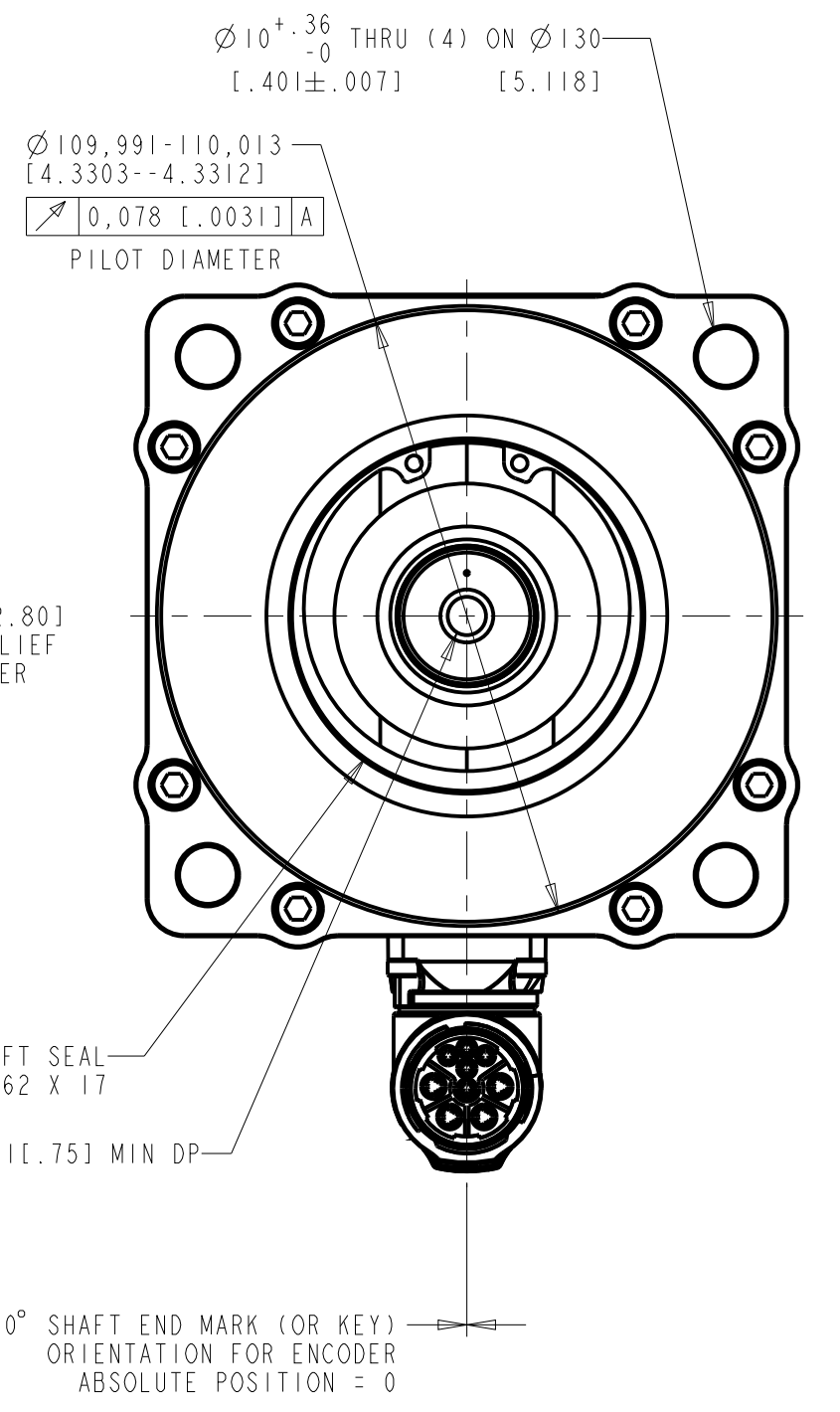
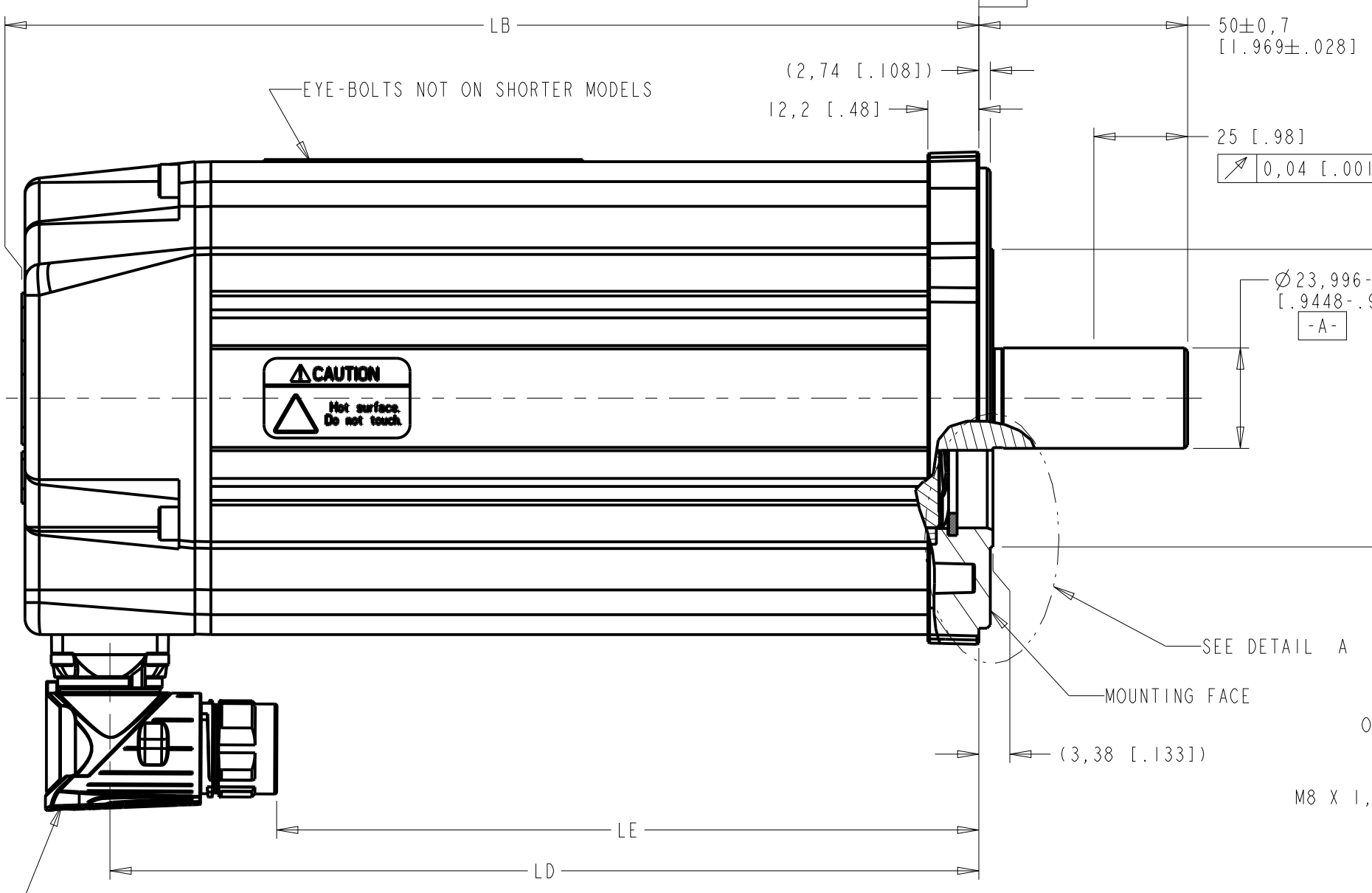

| PIN-OUT CONNECTOR | |
|-------------------|-----------|
| PIN | FUNCTION |
| A | U |
| B | V |
| C | W |
| ⊕ | GND |
| E | DSL+/EPWR |
| F | MBRK+ |
| G | MBRK- |
| H | DSL-/ECOM |
| L | - |

| MODEL | LB | LD | LE |
|-------|---------------|--------------|--------------|
| 1303 | 228,8 [9.01] | 207,8 [8.18] | 167,9 [6.61] |
| 1304 | 254,2 [10.01] | 233,2 [9.18] | 193,3 [7.61] |
| 1306 | 305 [12.01] | 284 [11.18] | 244,1 [9.61] |

- NOTE:
- DXF OF THIS DRAWING MUST BE SCALED TO LENGTH, SEE CHART ABOVE. MODEL SHOWN IS VPL-B1303x-xk14AA
 - 3D STEP (.stp) FILES AVAILABLE AT ALL LENGTHS.
 - COVERS SINGLE AND MULTI-TURN ABSOLUTE ENCODER 240V AND 480V MODELS (i.e., VPL-x130xx-Cx14xx and VPL-x130xx-Px14xx).

UNLESS OTHERWISE SPECIFIED
DO NOT SCALE DRAWING DIMENSIONS ARE IN MILLIMETERS WITH INCHES REFERENCED (X) UNTOLERANCED DIMENSIONS ARE REFERENCE
3RD ANGLE PROJECTION

Rockwell Automation

ESM, VPL, 130, BRK

Drawn by: JMREDIG Date: 11-04-2013

CONFIDENTIAL AND PROPRIETARY INFORMATION. THIS DOCUMENT CONTAINS CONFIDENTIAL AND PROPRIETARY INFORMATION OF ROCKWELL AUTOMATION, INC. AND MAY NOT BE USED, COPIED OR DISCLOSED TO OTHERS, EXCEPT WITH THE AUTHORIZED WRITTEN PERMISSION OF ROCKWELL AUTOMATION, INC.

| | | |
|--------------|-------------|----|
| Sheet 1 Of 1 | | |
| Size | Ver | |
| C | 10000169951 | 02 |