

APPROX. WEIGHT (LBS)
11

ECO No	DESCRIPTION	REV BY	DATE

CRITICAL TO QUALITY CLASSIFICATION TABLE				
P-PROFORMANCE FIT ASSEMBLY F-IDENTIFIABLE CLASSIFICATION S-ENGINEERING MANUFACTURING REQUIREMENT R-REGULATORY REQUIREMENT/COMPLIANCE MANDATORY				
COMMENTS	DRAWING ZONE	F	A	R
ROHS	G1-H1			X

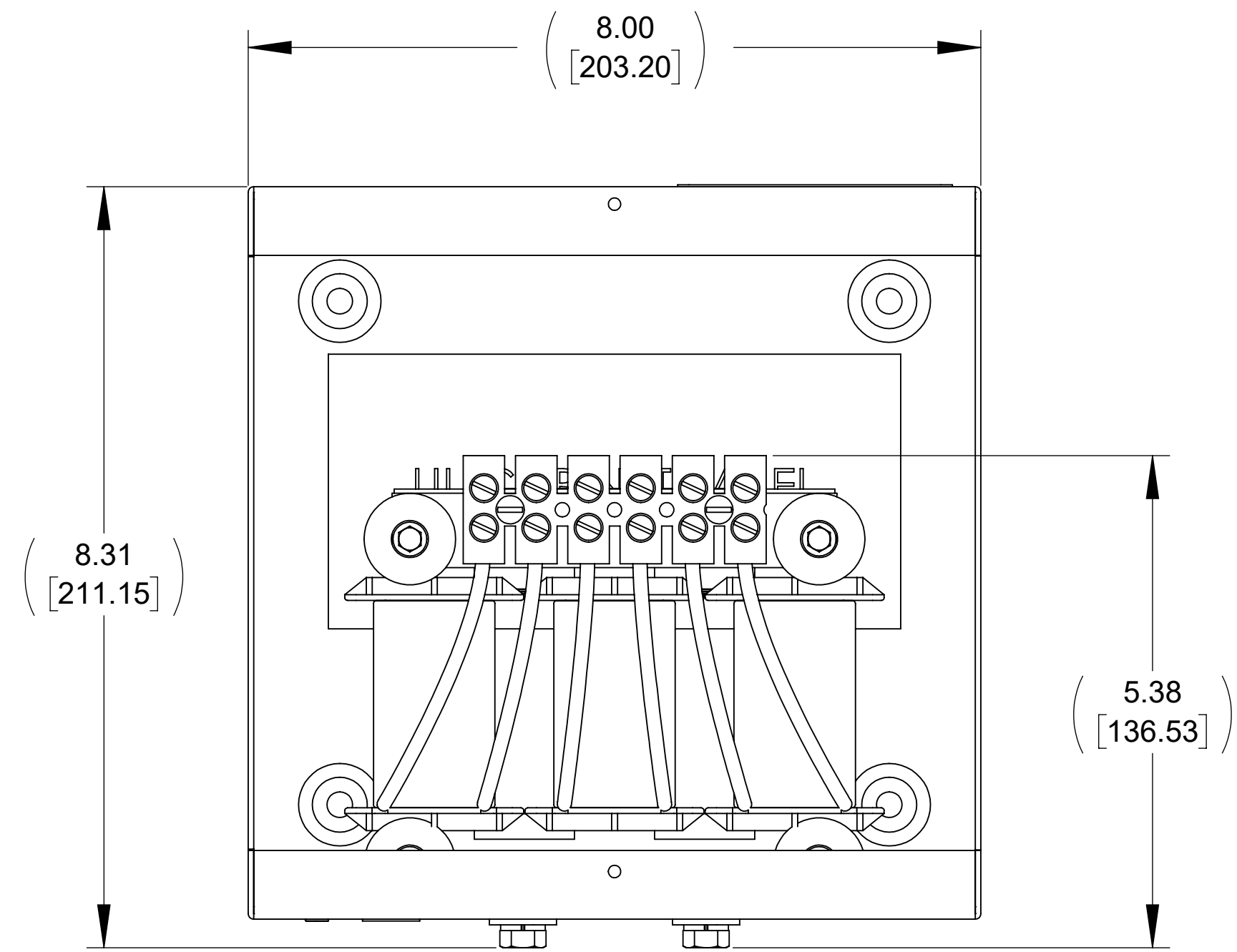

FRONT VIEW (PANELS REMOVED)

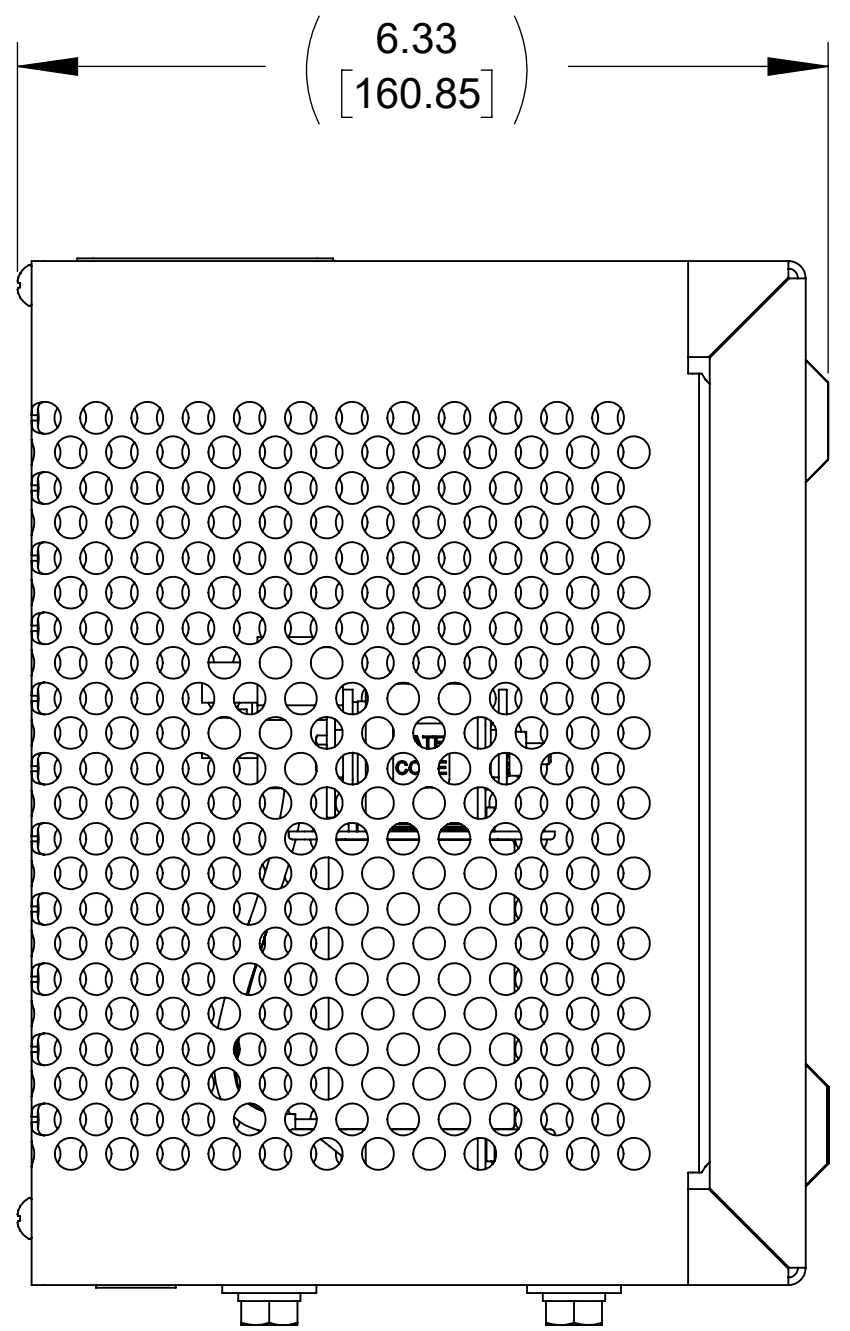

SIDE VIEW

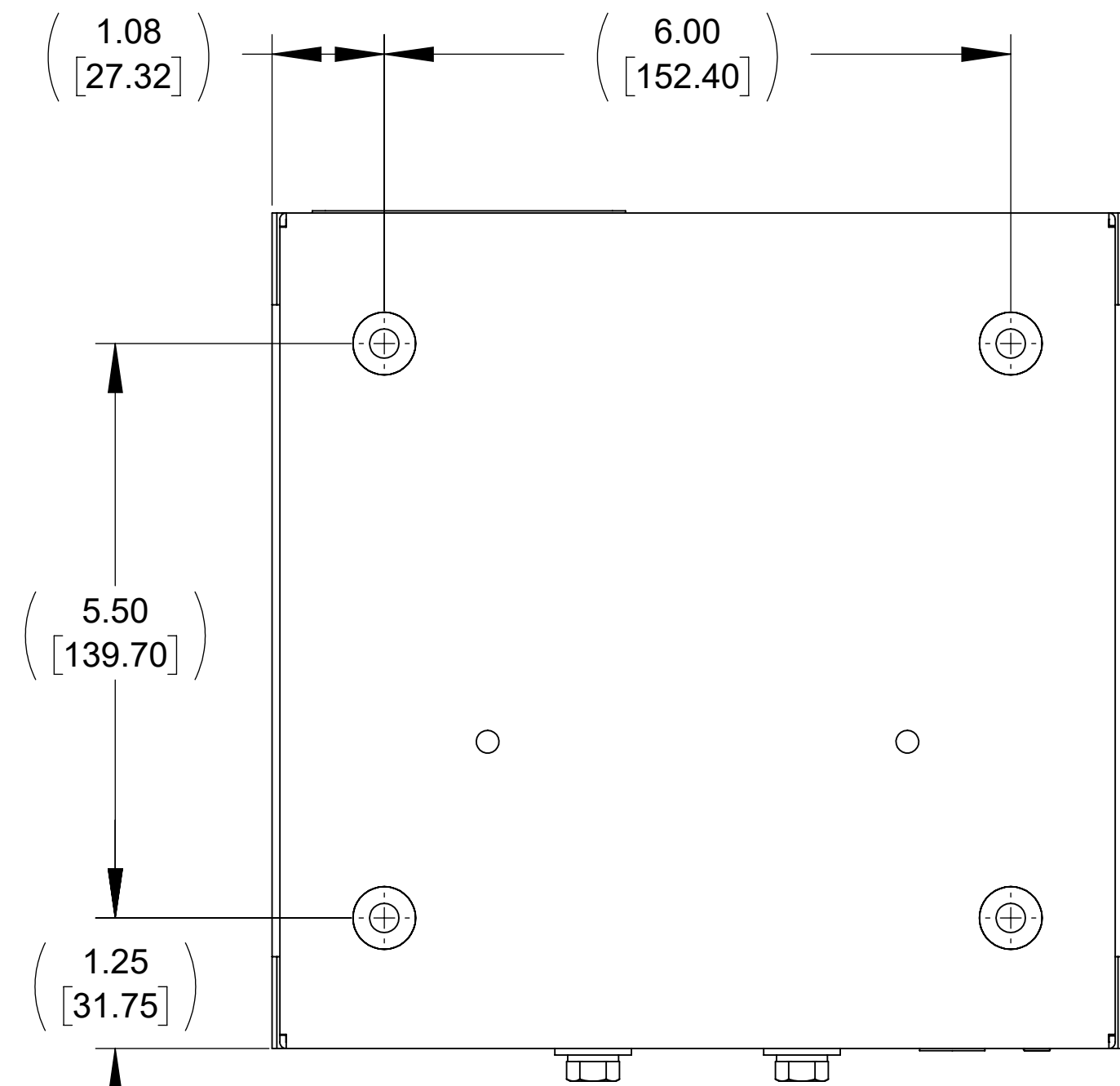

REAR VIEW

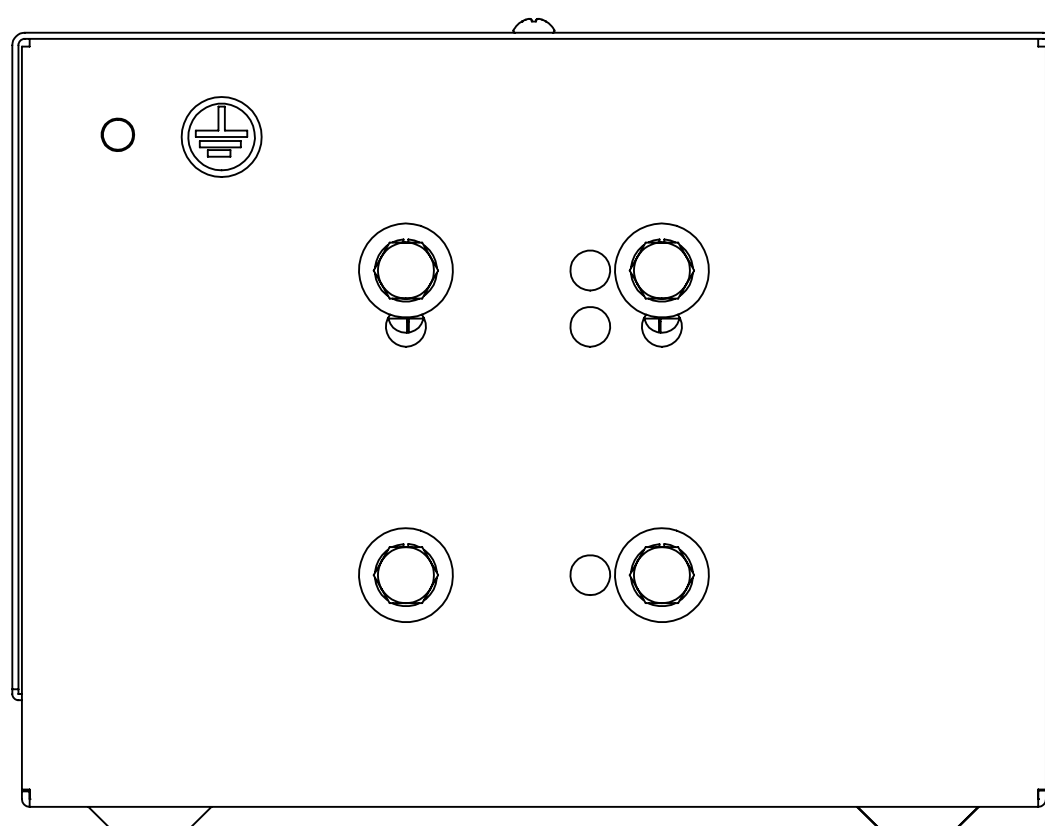

BOTTOM VIEW

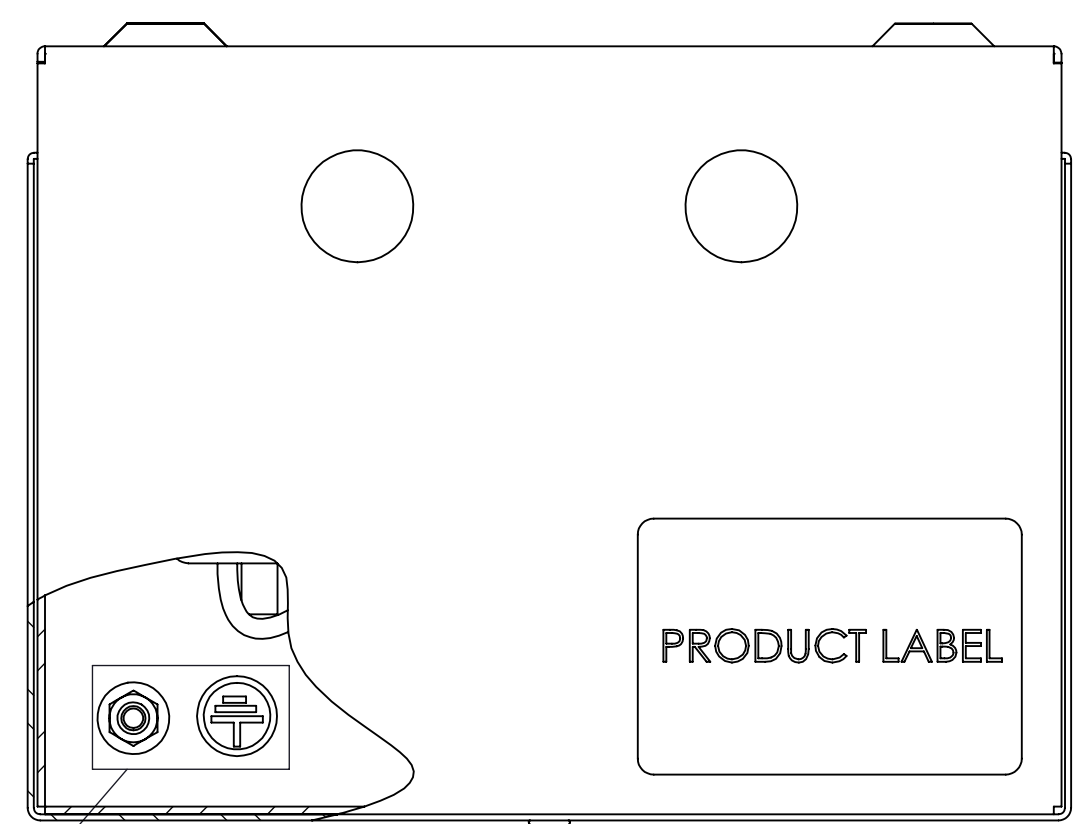

TOP VIEW

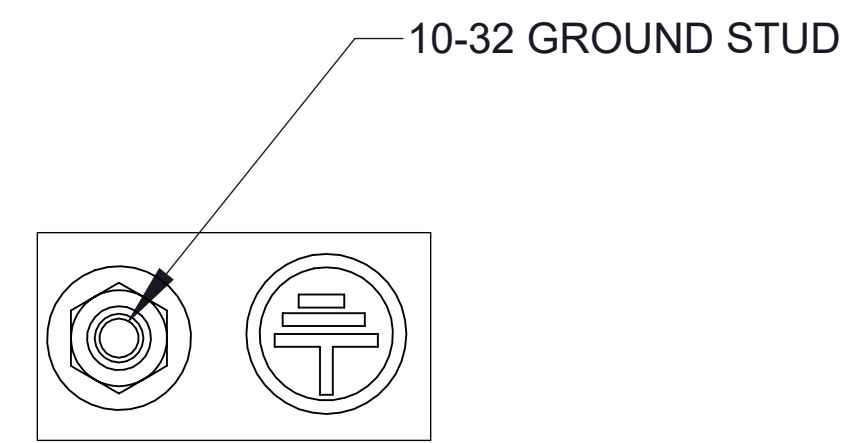

DETAIL A

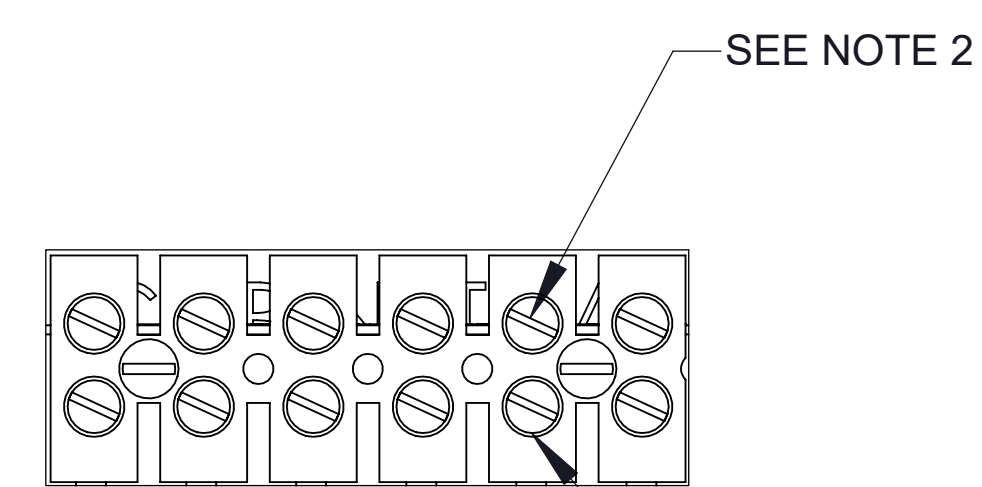

CUSTOMER CONNECTION DETAIL VIEW

NOTES:

1. TERMINAL WIRE RANGE: 4-14 AWG.
2. TERMINAL SCREW TIGHTENING TORQUE: 16 IN.LBS.

THE COMPONENT, PART OR ASSEMBLY DESCRIBED IN THIS DOCUMENT MUST COMPLY WITH THE EU (EUROPEAN UNION) DIRECTIVE ROHS2 CONTAINS <0.1% OF ANY SVHC BY WEIGHT PER REACH REGULATION		MATERIAL		CONFIDENTIAL AND PROPRIETARY INFORMATION THIS DOCUMENT CONTAINS CONFIDENTIAL AND PROPRIETARY INFORMATION OF MTE CORPORATION AND MAY NOT BE USED, COPIED OR DISCLOSED TO OTHERS EXCEPT WITH THE AUTHORIZED WRITTEN PERMISSION OF MTE CORPORATION	
UNLESS OTHERWISE SPECIFIED DIMENSIONS ARE IN INCHES [MM] TOLERANCES ARE: ANGLES: ± 1° 1 PLACE .X: ± .1 [2.5] 2 PLACE .XX: ± .03 [0.76] 3 PLACE .XXX: ± .010 [0.254]				DESCRIPTION LINE/LOAD REACTOR w/ENCLOSURE	
DRAWN WF CHECKED WF APPROVED PY	DATE 01/22/20 DATE 01/24/20 DATE 01/24/20	SIZE D SCALE 1:1.5	DWG No. CD 1321-3RA12-A	REV 00	SHEET 1 OF 1