

APPROX. WEIGHT (LBS)
53

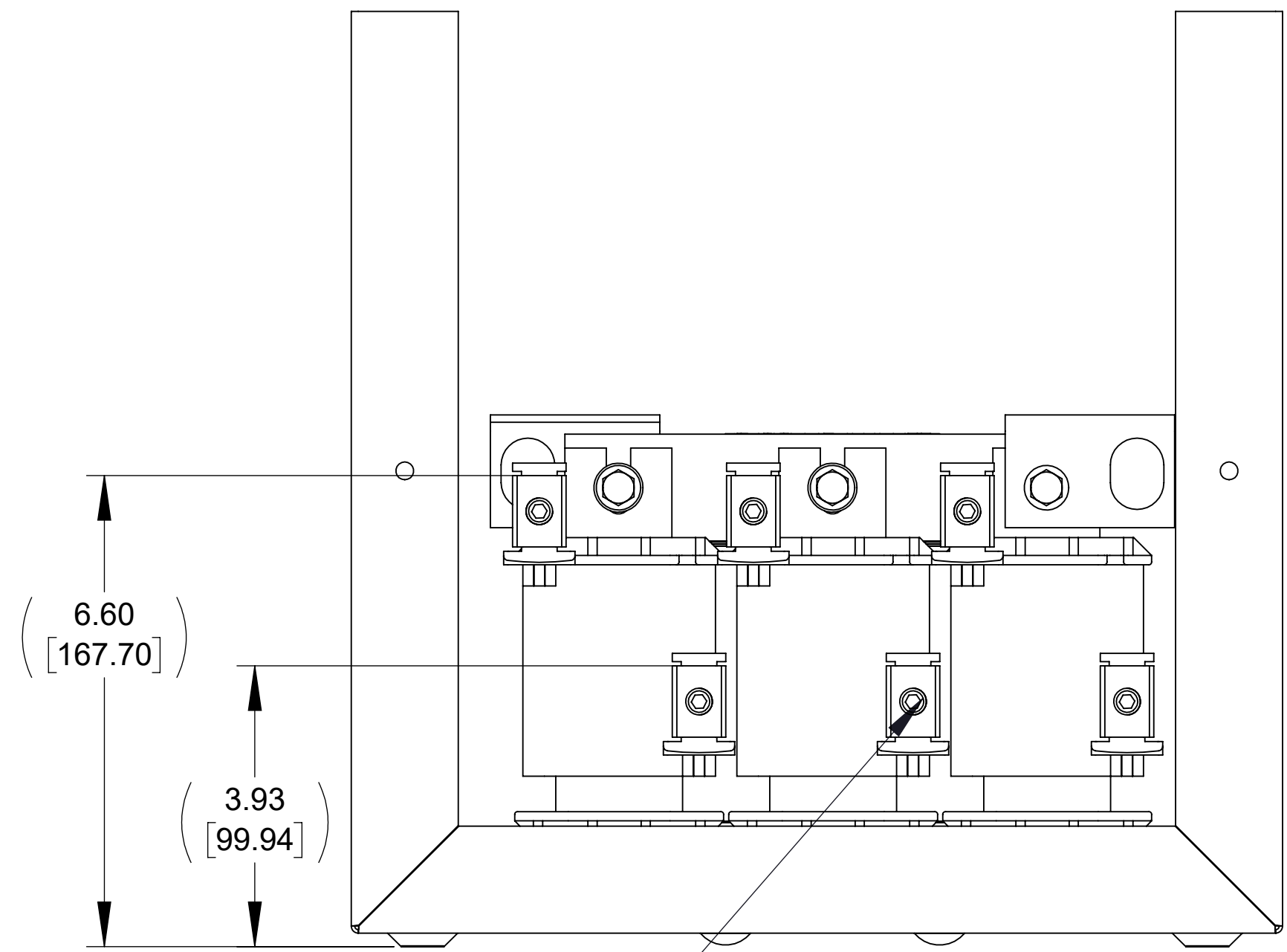

SEE NOTE 2

FRONT VIEW
(PANEL REMOVED)

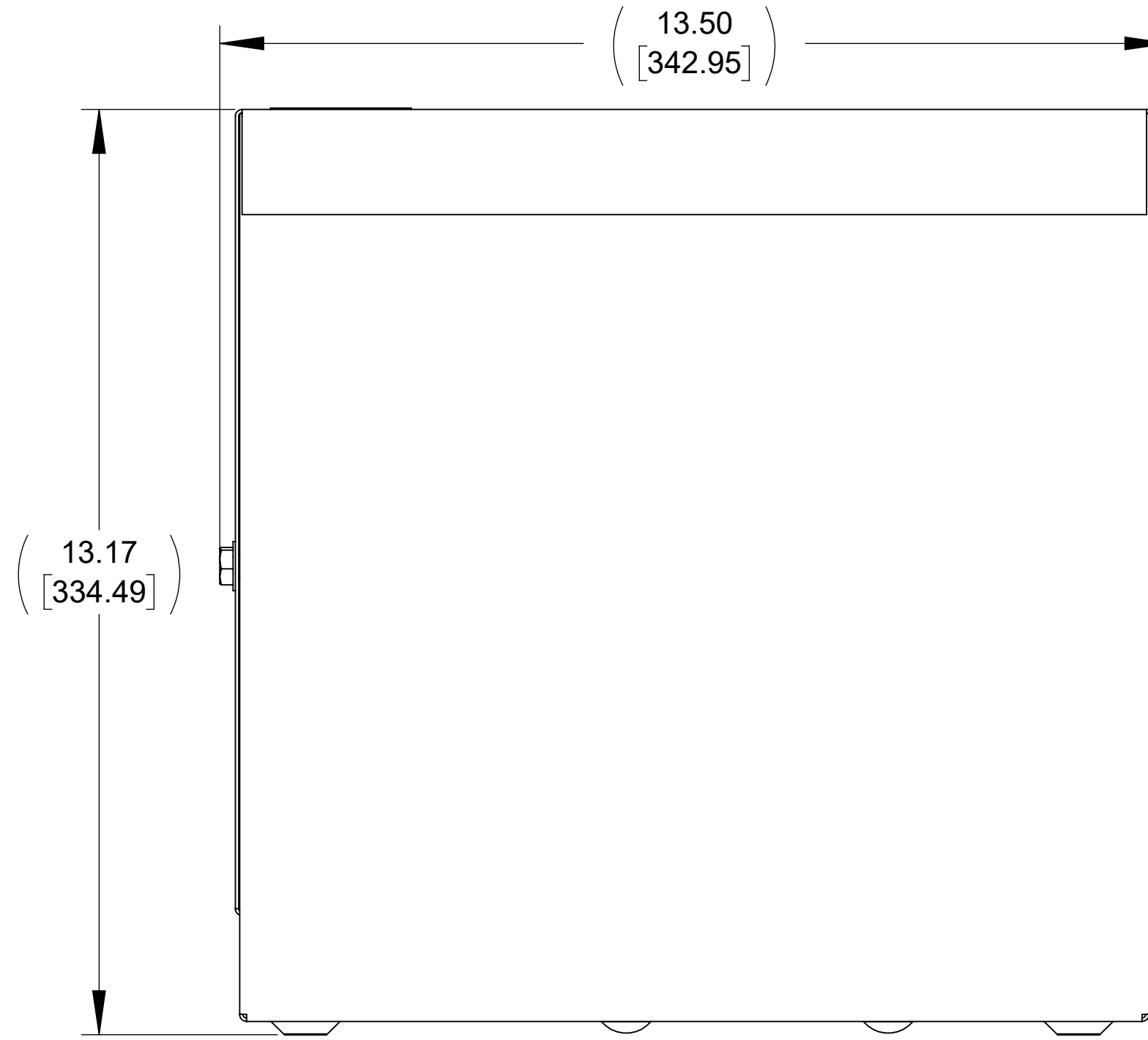

SIDE VIEW

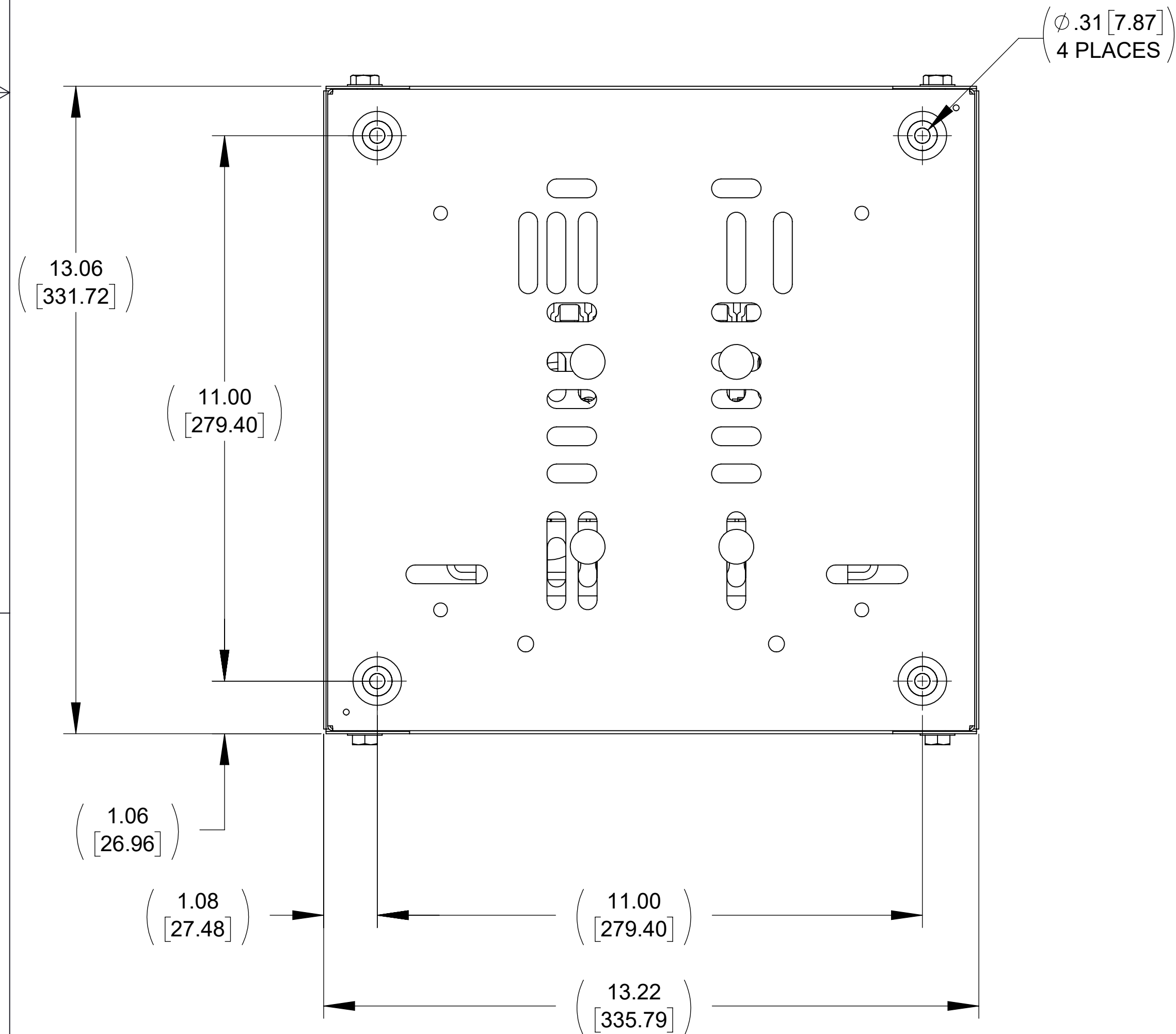
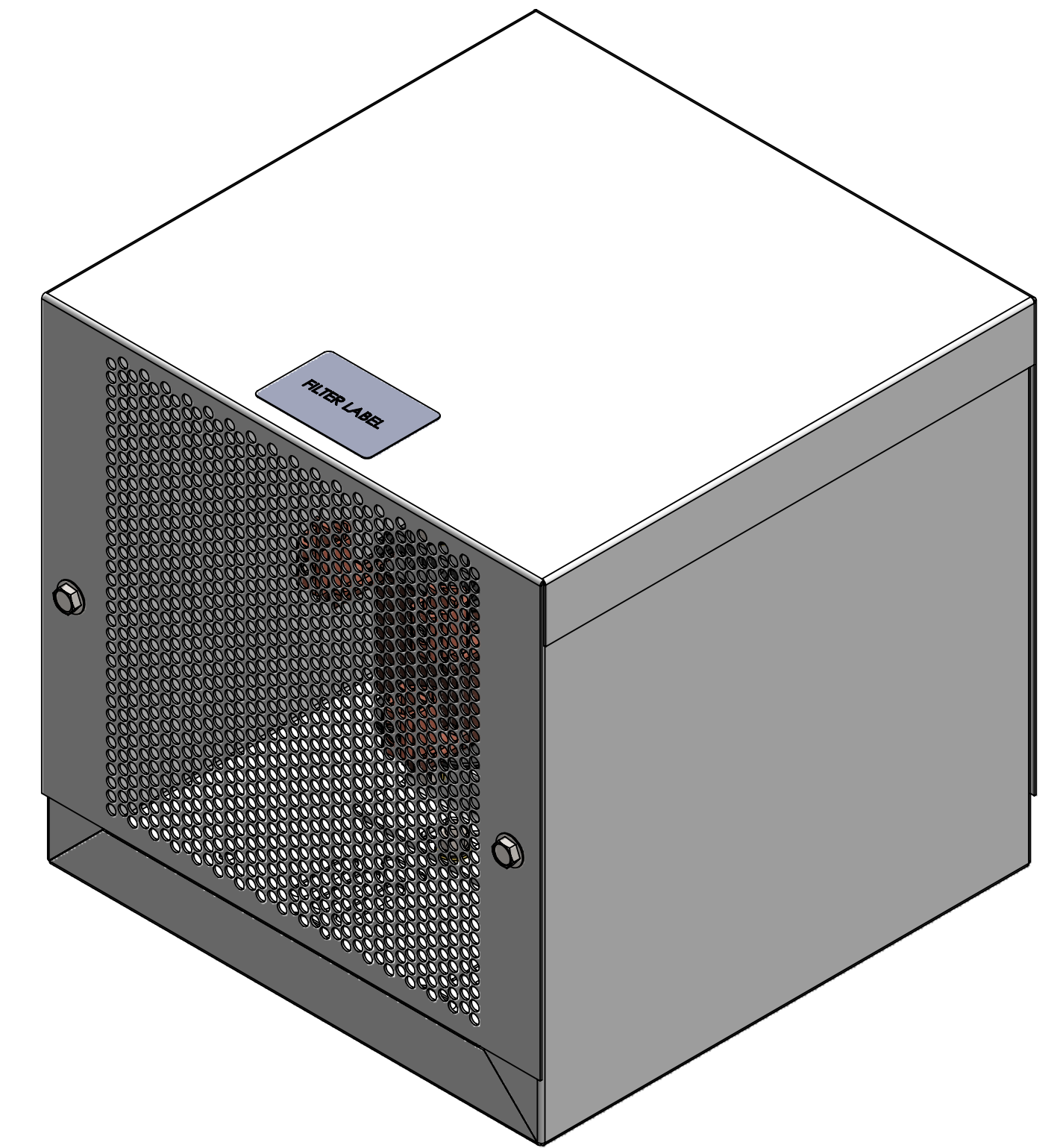

BOTTOM VIEW

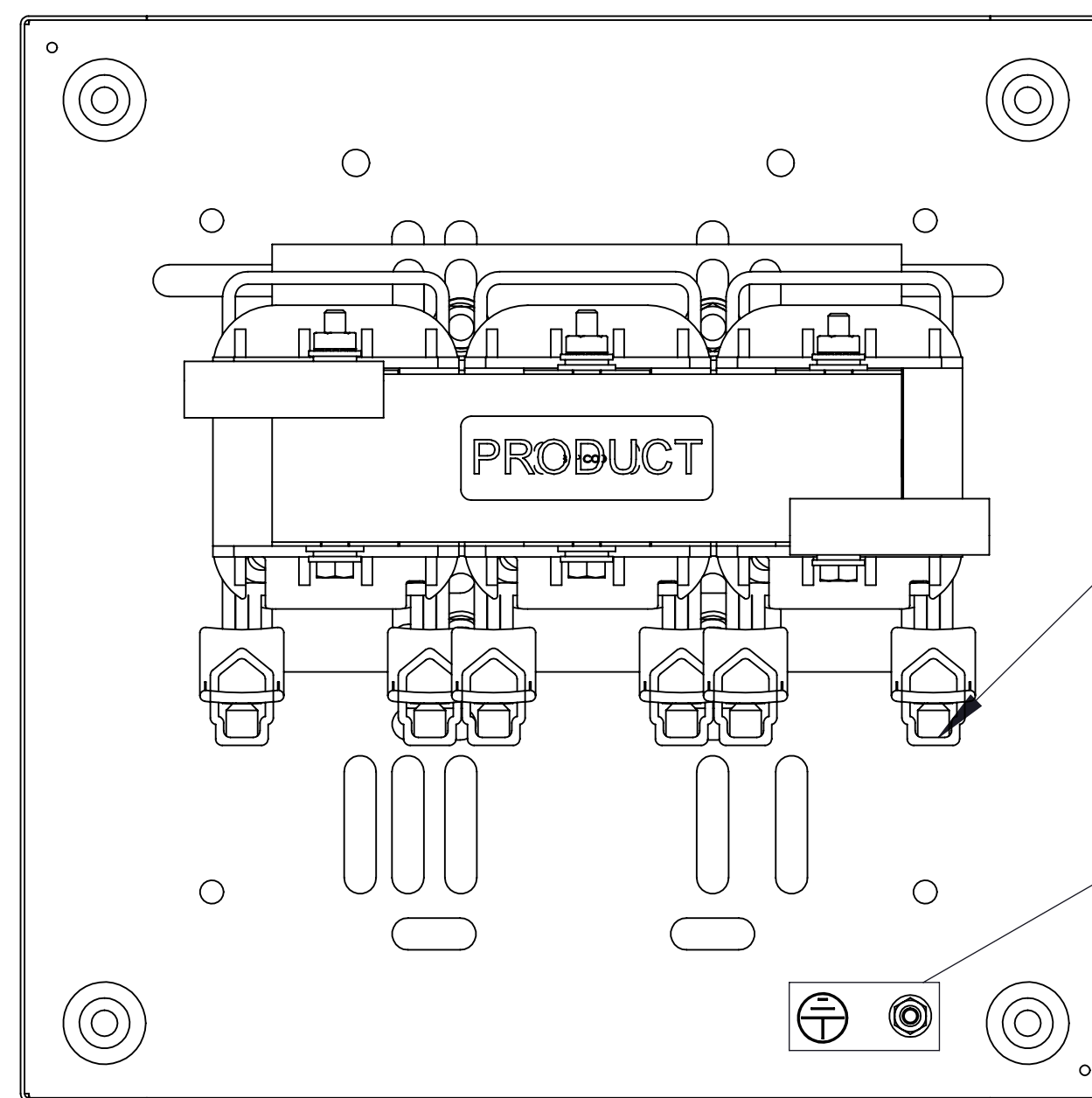

TOP VIEW
(PANEL REMOVED)

#10-32 GROUND STUD

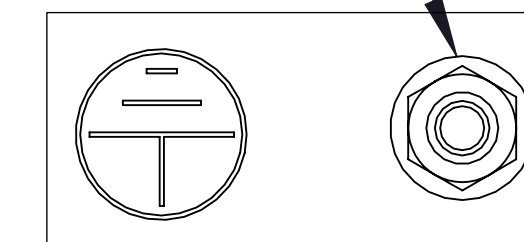

SEE NOTE 1

NOTES:

1. TERMINAL WIRE RANGE: 6-0 AWG.
2. TERMINAL SCREW TIGHTENING TORQUE: 6-4 (45 IN/LBS, 2-0 (50 IN/LBS).
3. REFER TO USER MANUAL FOR COMPLETE INSTALLATION INSTRUCTIONS.

Rockwell Automation

THE COMPONENT, PART OR ASSEMBLY DESCRIBED IN THIS DOCUMENT MUST COMPLY WITH THE EU (EUROPEAN UNION) DIRECTIVE RoHS2

CONTAINS <0.1% OF ANY SVHC BY WEIGHT PER REACH REGULATION

UNLESS OTHERWISE SPECIFIED DIMENSIONS ARE IN INCHES [MM] TOLERANCES ARE:

- ANGLES: $\pm 1^\circ$
 1 PLACE .X: $\pm .1 [2.5]$
 2 PLACE .XX: $\pm .03 [0.76]$
 3 PLACE .XXX: $\pm .010 [0.254]$

MATERIAL

| | | | |
|----------|----|------|----------|
| DRAWN | WF | DATE | 01/22/20 |
| CHECKED | WF | DATE | 01/23/20 |
| APPROVED | PY | DATE | 01/24/20 |

CONFIDENTIAL AND PROPRIETARY INFORMATION
THIS DOCUMENT CONTAINS CONFIDENTIAL AND PROPRIETARY INFORMATION OF MTE CORPORATION AND MAY NOT BE USED, COPIED OR DISCLOSED TO OTHERS EXCEPT WITH THE AUTHORIZED WRITTEN PERMISSION OF MTE CORPORATION

DESCRIPTION

LINE/LOAD REACTOR w/ENCL O SURE=

| | | | | | |
|-------|-----|---------|------------------|-----|--------------|
| SIZE | D | DWG No. | CD 1321-3RA160-A | REV | 00 |
| SCALE | 1:2 | | | | SHEET 1 OF 1 |

| ECO No | DESCRIPTION | REV BY | DATE |
|--------|-------------|--------|------|
| | | | |

CRITICAL TO QUALITY CLASSIFICATION TABLE

P-PROFORMANCE FIT (ASSEMBLY)
 F-IDENTIFIED APPLICABLE CLASSIFICATIONS
 E-ENGINEERING AND/OR MANUFACTURING REQUIREMENT
 R-REGULATORY REQUIREMENT (COMPLIANCE IS MANDATORY)

| COMMENTS | DRAWING ZONE | P | F | E | R |
|----------|--------------|---|---|---|---|
| ROHS | G1-H1 | | | | X |