

CRITICAL TO QUALITY CLASSIFICATION TABLE				
P=PERFORMANCE, F=FIT, A=ASSEMBLY				
X=IDENTIFIES APPLICABLE CLASSIFICATION(S)				
◇=ENGINEERING AND/OR MANUFACTURING REQUIREMENT				
Ⓢ=REGULATORY REQUIREMENT-CONFORMANCE IS MANDATORY				
COMMENTS	DRAWING ZONE	P	F	A
ROHS	GI-HI			X

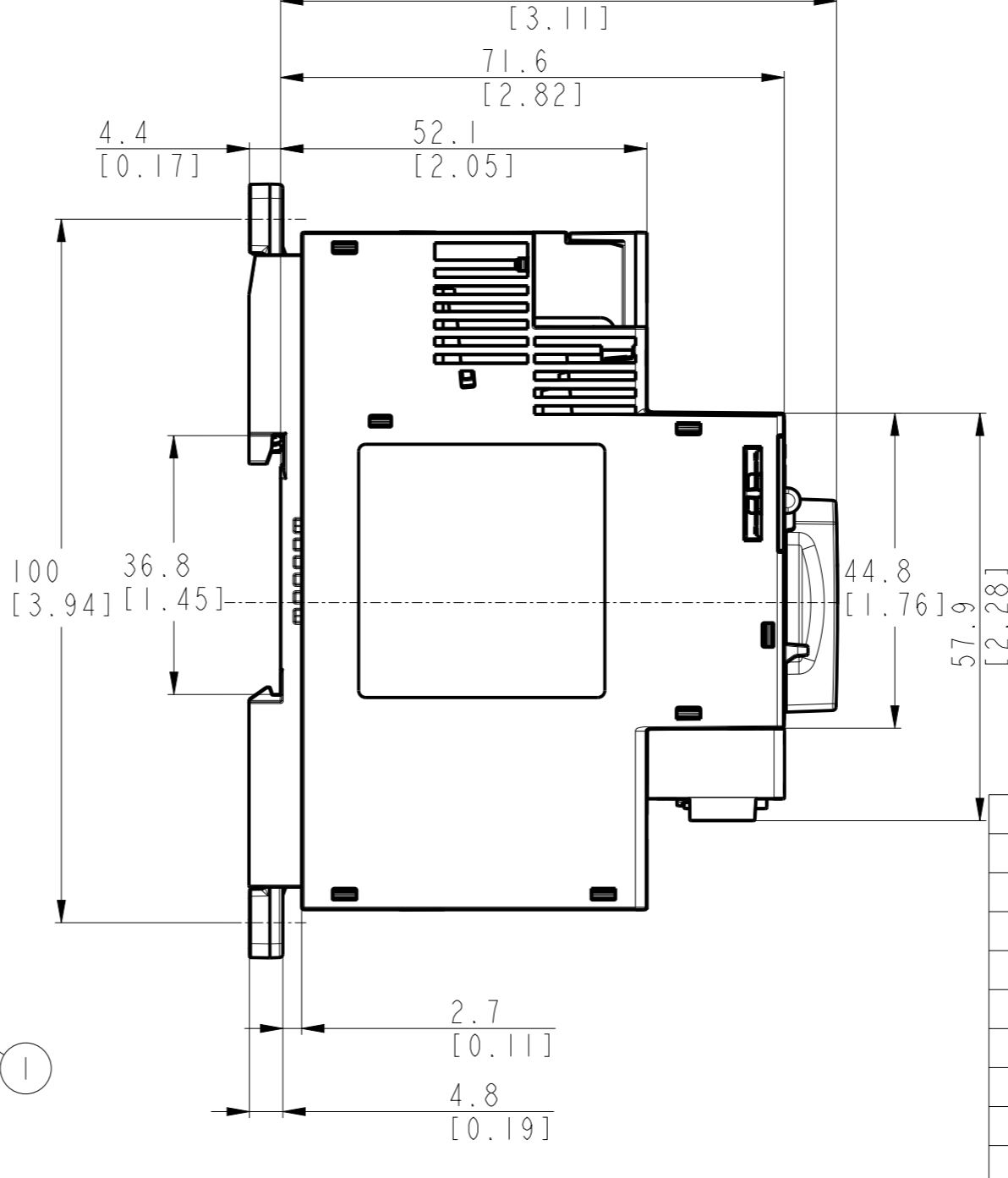
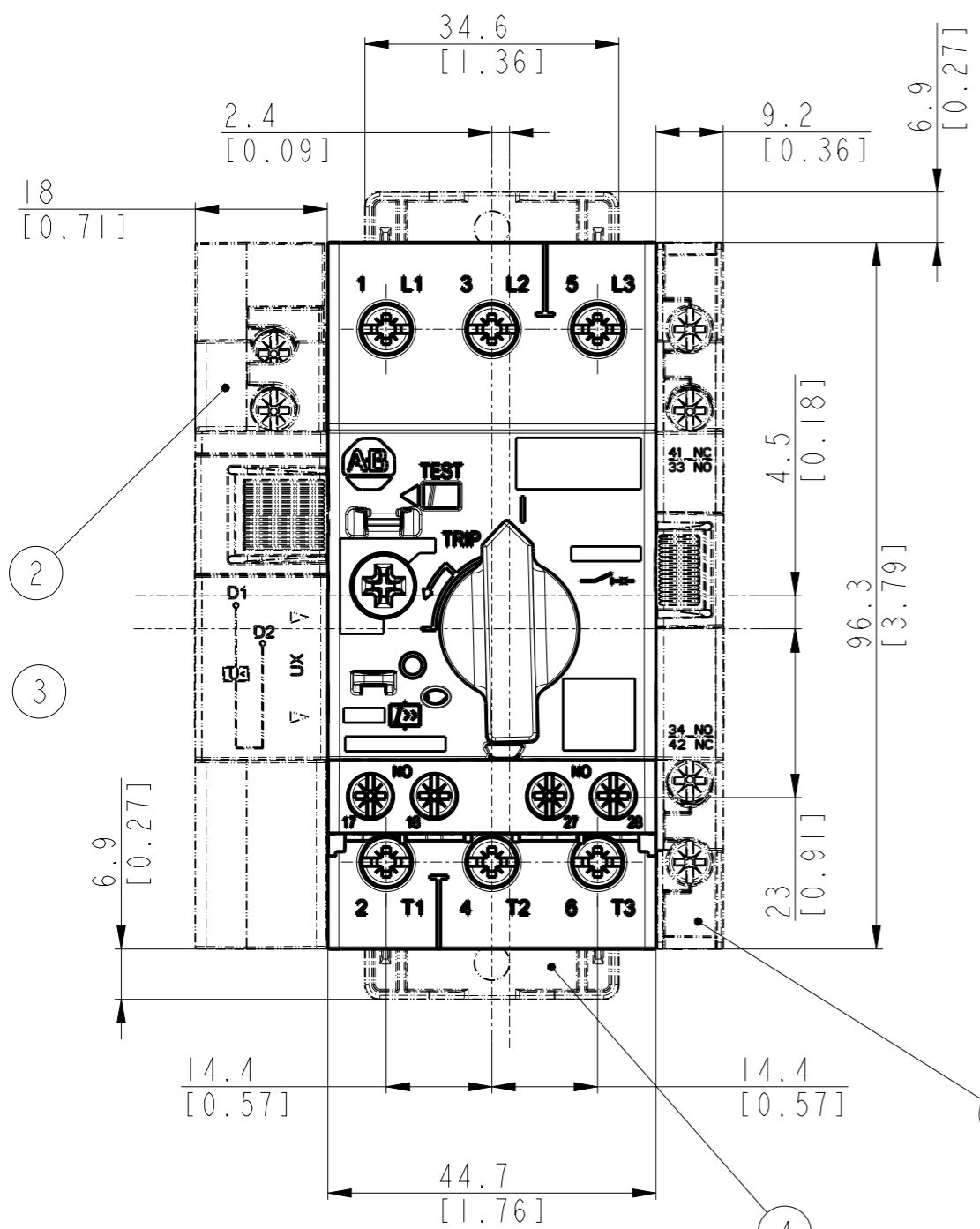
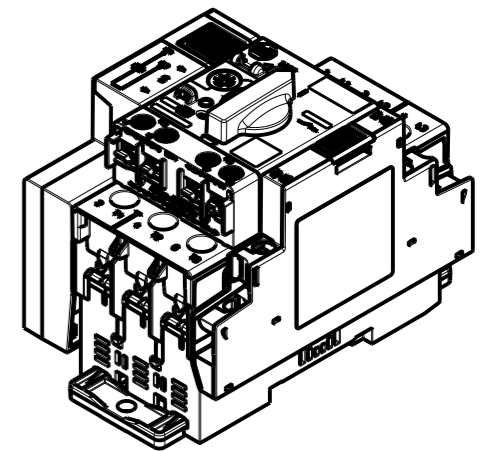

Catalog No	Model /Dir No	Material No
I40MT-C3E-C32	10003311756	PN-494444
I40MT-C3E-C29		PN-494443
I40MT-C3E-C25		PN-494442
I40MT-C3E-C20		PN-494441
I40MT-C3E-C16		PN-494440
I40MT-C3E-C10		PN-494439
I40MT-C3E-B63		PN-494438
I40MT-C3E-B40		PN-494437
I40MT-C3E-B25		PN-494436
I40MT-C3E-B16		PN-494435
I40MT-C3E-B10		PN-494434
I40MT-C3E-A63		PN-494430
I40MT-C3E-A40		PN-494422
I40MT-C3E-A25		PN-494421
I40MT-C3E-A16		PN-494401

- ① Side Mounted, Auxiliary Contact I40MT-C-ASA*
- ② Undervoltage trip or Shunt trip I40MT-C-UX*
I40MT-C-SN*
- ③ Front Mount, Auxiliary Contact I40MT-C-AFA*
- ④ Screw Mounting Adapter I40MT-C-N45

MUST COMPLY WITH ROCKWELL AUTOMATION ENVIRONMENTAL SPECIFICATION 970-20-01

-Dimensions are shown in mm [inches]
-Dimensions are not intended to be used for manufacturing purposes

ALL UNDIMENSIONED GEOMETRIES ARE CONTROLLED BY THE CAD MODEL. IN CASE OF DIMENSION DISCREPANCY, CAD MODEL OVERRIDES.



CONFIDENTIAL AND PROPRIETARY INFORMATION. THIS DOCUMENT CONTAINS CONFIDENTIAL AND PROPRIETARY INFORMATION OF ROCKWELL AUTOMATION, INC. AND MAY NOT BE USED, COPIED OR DISCLOSED TO OTHERS, EXCEPT WITH THE AUTHORIZED WRITTEN PERMISSION OF ROCKWELL AUTOMATION, INC.

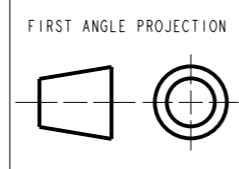

DESCRIPTION	140MT-C3E	
CREATED BY:RPAMPAT	CHANGED BY:PKLANDE	

DATE: 2021-08-20		SHEET 1 OF 1	
SIZE	DIR	VER	
A3	10005888483	00	