

FLANGE 4P ASSEMBLY

ITEM	DESCRIPTION	QTY	AB CAT NUMBER
1	MOLDED CASE CIRCUIT BREAKER	1	140G-G-4P CB
2	FLANGE 4P	1	140G-G-EP4

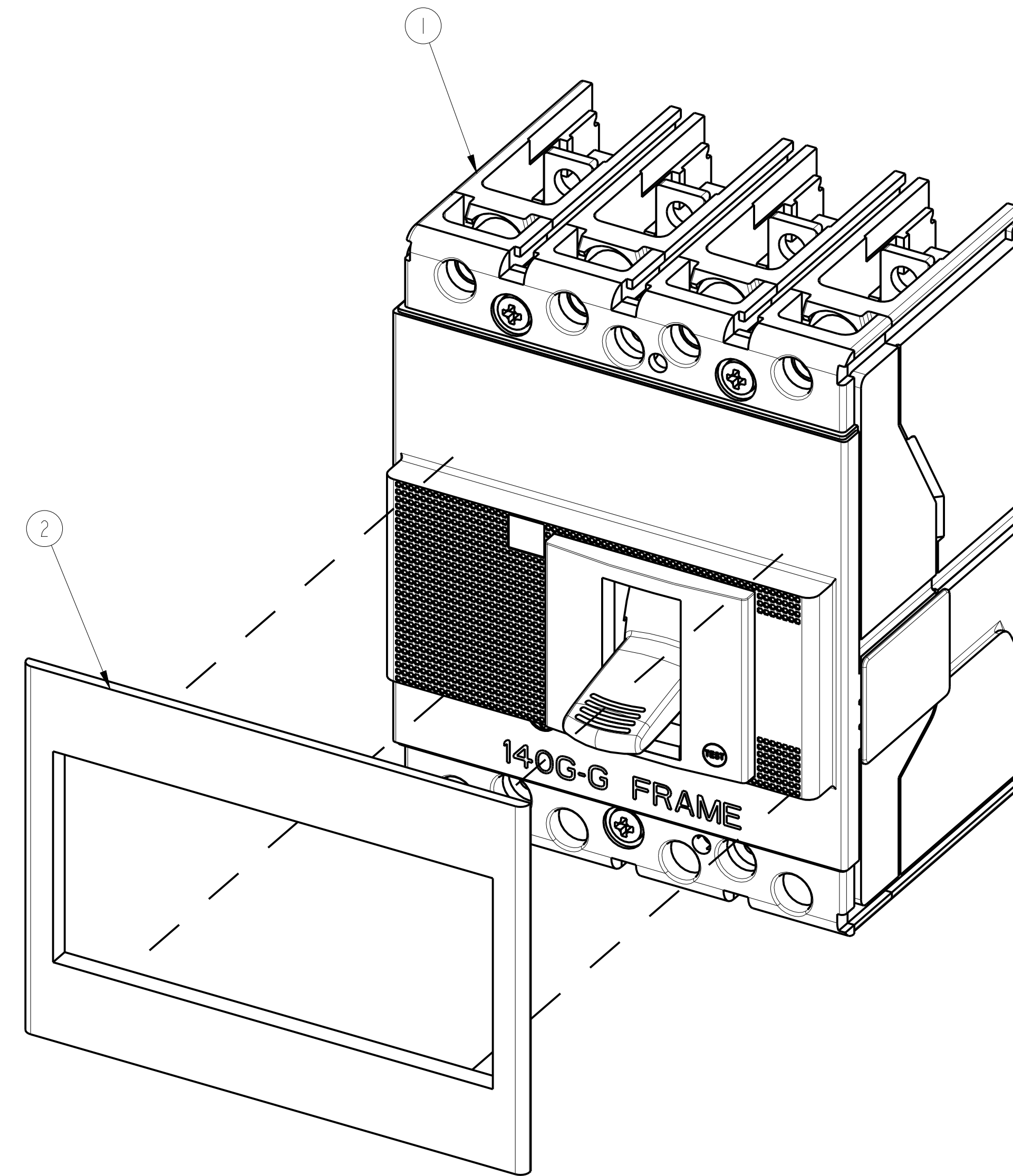

FLANGE 4P ASSEMBLED TO 140G-G-4-POLE
SCALE 1.3:1

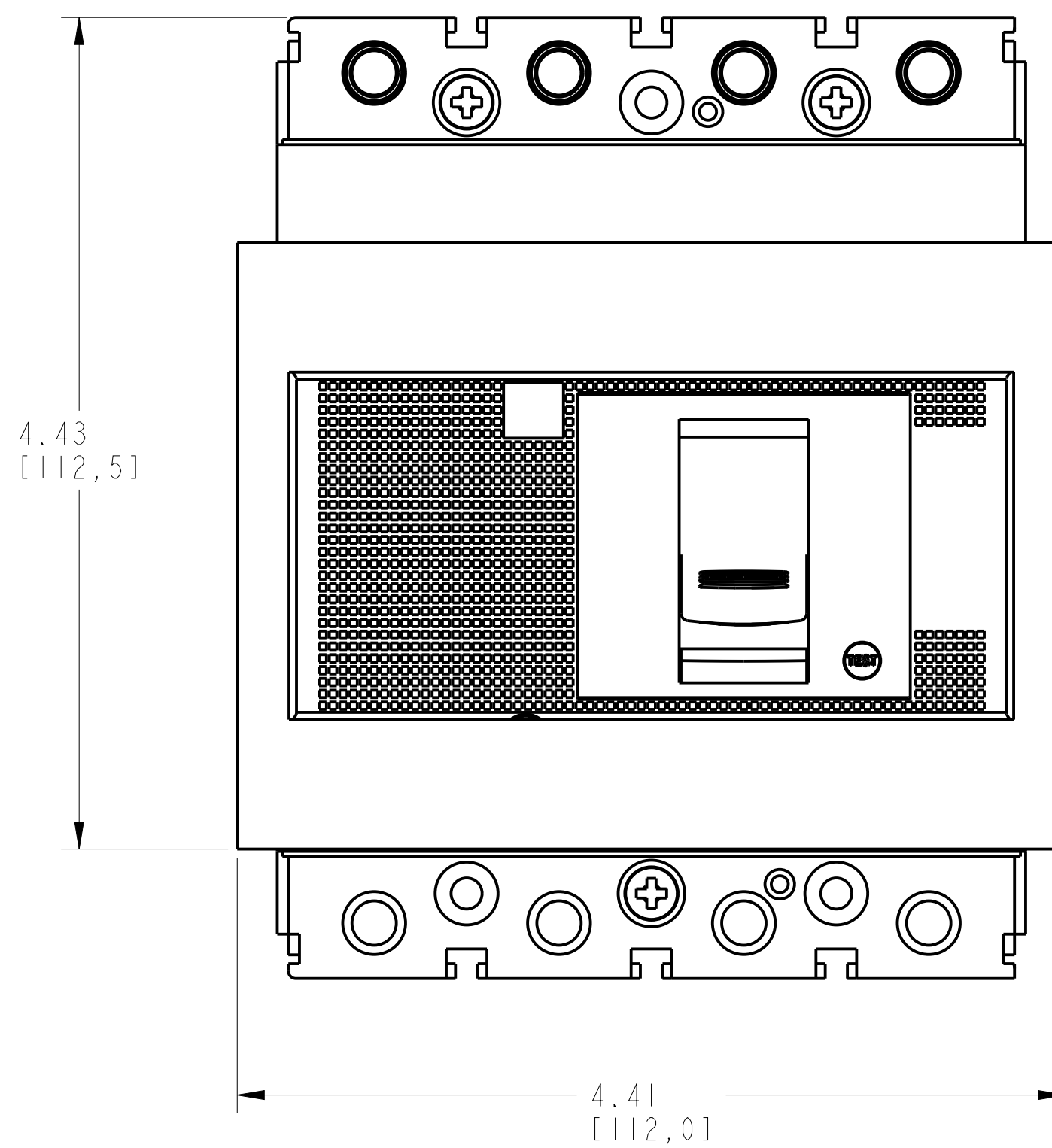
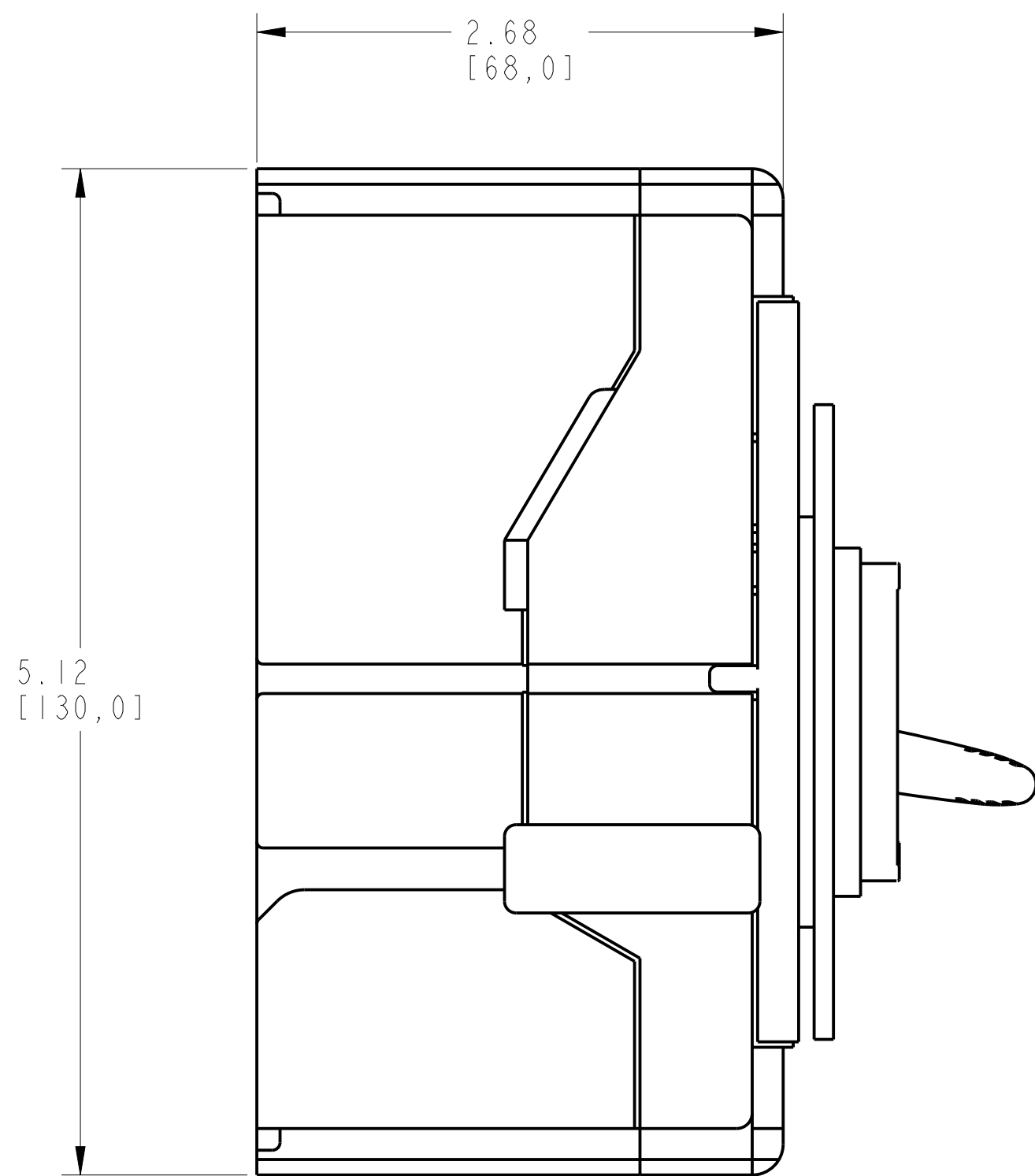
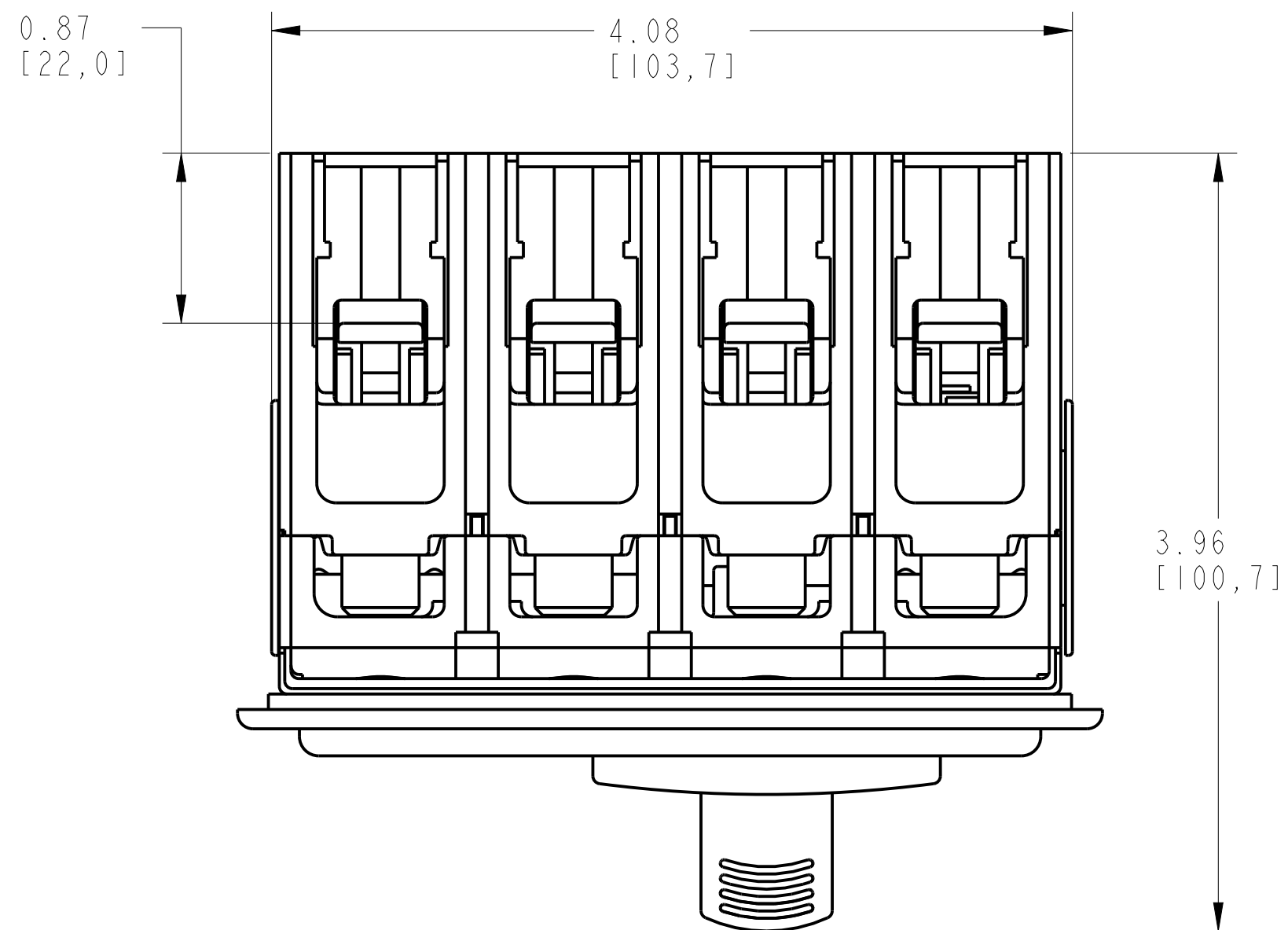
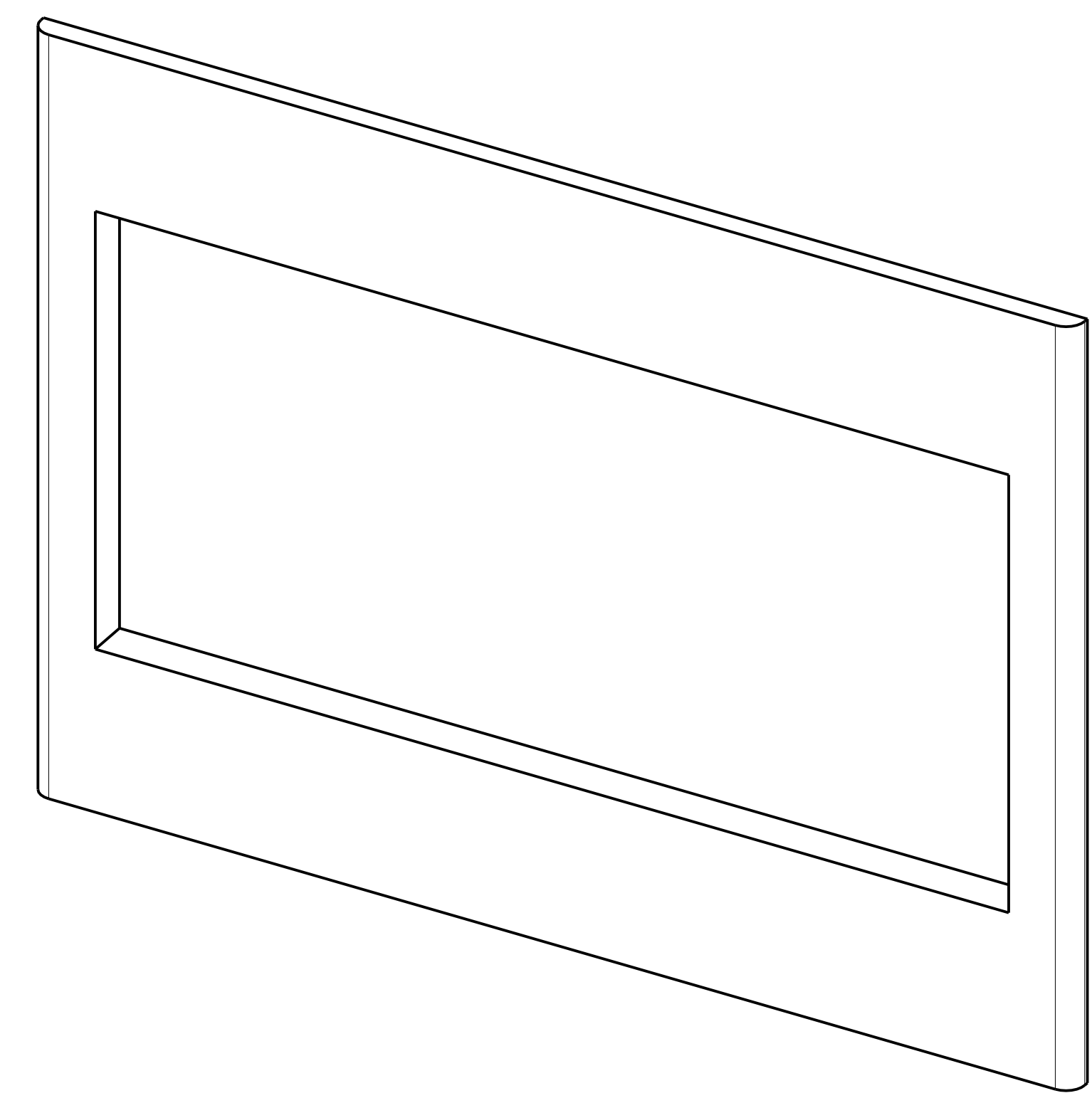
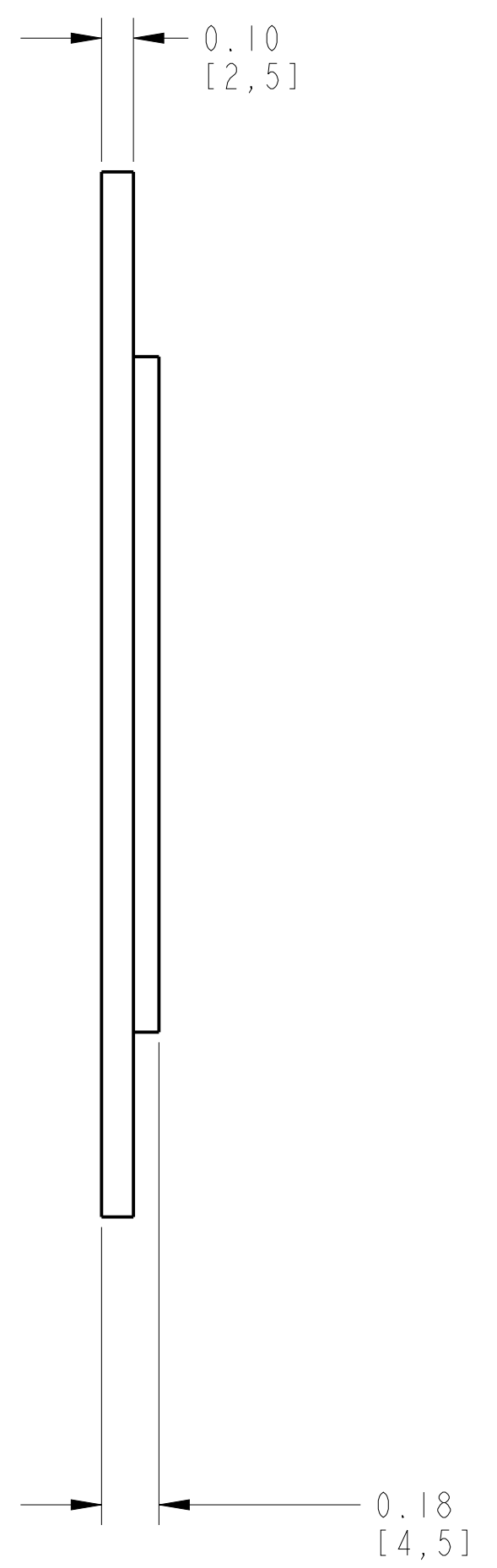
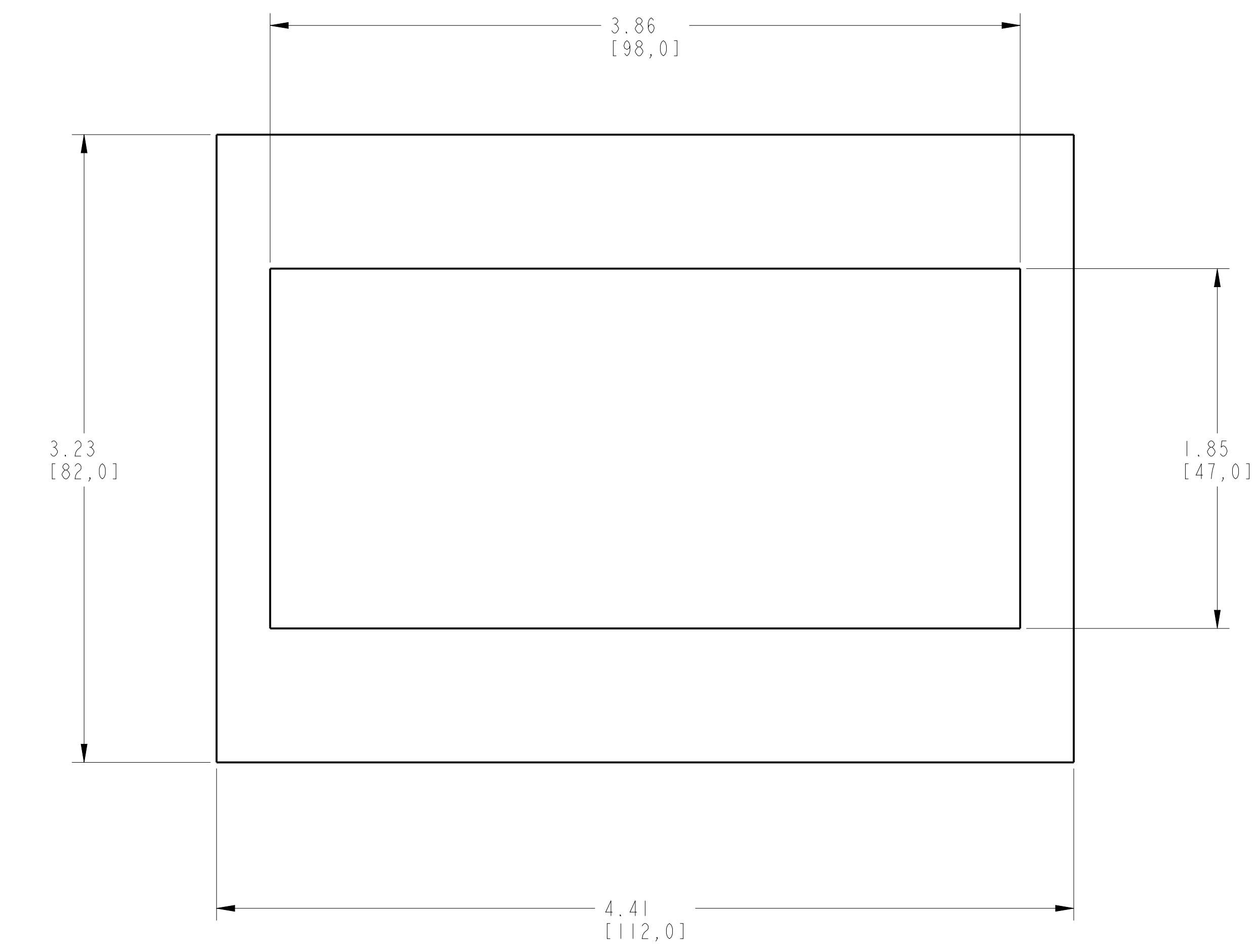

ISOMETRIC VIEW

ITEM 2 : FLANGE 4P
SCALE 2:1

		<small>CONFIDENTIAL AND PROPRIETARY INFORMATION. THIS DOCUMENT CONTAINS CONFIDENTIAL AND PROPRIETARY INFORMATION OF ROCKWELL AUTOMATION, INC. AND MAY NOT BE USED, COPIED OR DISCLOSED TO OTHERS, EXCEPT WITH THE AUTHORIZED WRITTEN PERMISSION OF ROCKWELL AUTOMATION, INC.</small>	
		Sheet 2 Of 2	
FLANGE 4P ASSEMBLED TO 140G-G-4P CB		Size D	Ver 00
Drawn by: UMUNUSW	Date: 10-25-13	1000853675	