

CRITICAL TO QUALITY CLASSIFICATION TABLE					
P=PERFORMANCE, F=FIT, A=ASSEMBLY					
X=IDENTIFIES APPLICABLE CLASSIFICATION(S)					
◇=ENGINEERING AND/OR MANUFACTURING REQUIREMENT					
⊗=REGULATORY REQUIREMENT-CONFORMANCE IS MANDATORY					
COMMENTS	DRAWING ZONE	P	F	A	R
ROHS	G1-H1				X

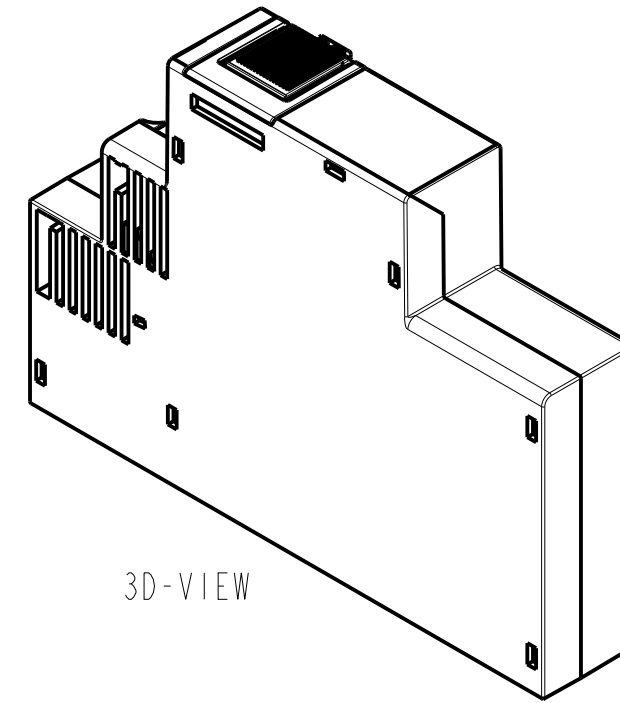
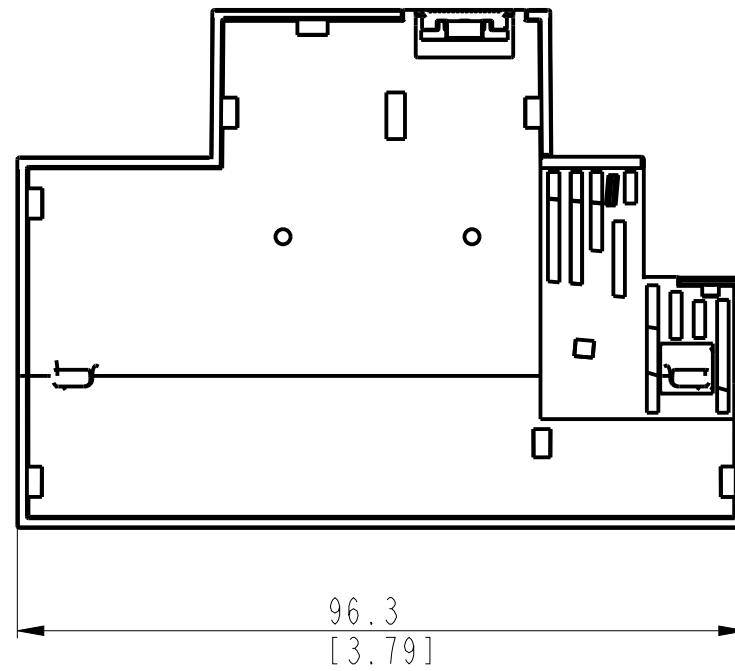
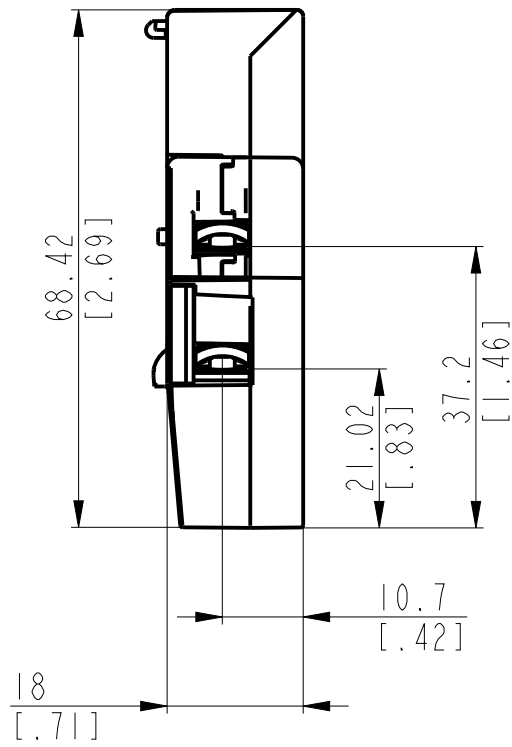

Catlog No.	Model/Dir No	Part No
140MT-C-SNK	10005886176	PN-514007
140MT-C-SND		PN-514008
140MT-C-SNF		PN-514009
140MT-C-SNA		PN-514013
140MT-C-SNT		PN-514014
140MT-C-SNN		PN-514015
140MT-C-SNB		PN-514021
140MT-C-SNZJ		PN-514022
140MT-C-UXK		PN-514024
140MT-C-UXD		PN-514025
140MT-C-UXF		PN-514026
140MT-C-UXA		PN-514029
140MT-C-UXN		PN-514030
140MT-C-UXB	PN-514032	

-Dimensions are shown in mm [inches]
 -Dimensions are not intended to be used for manufacturing purposes

MUST COMPLY WITH ROCKWELL AUTOMATION ENVIRONMENTAL SPECIFICATION 970-20-01



ALL UNDIMENSIONED GEOMETRIES ARE CONTROLLED BY THE CAD MODEL. IN CASE OF DIMENSION DISCREPANCY, CAD MODEL OVERRIDES.



CONFIDENTIAL AND PROPRIETARY INFORMATION. THIS DOCUMENT CONTAINS CONFIDENTIAL AND PROPRIETARY INFORMATION OF ROCKWELL AUTOMATION, INC. AND MAY NOT BE USED, COPIED OR DISCLOSED TO OTHERS, EXCEPT WITH THE AUTHORIZED WRITTEN PERMISSION OF ROCKWELL AUTOMATION, INC.

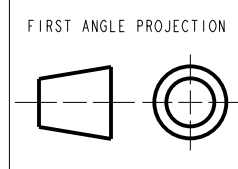

DESCRIPTION
140MT-C-SN/UX Customer Drawing
 CREATED BY:T.Polak CHANGED BY:PKLANDE

DATE:2021-08-19 SHEET 1 OF 1
 SIZE DIR VER
A3 10005900982 00