



en Installation instructions

de Installationsanleitung

fr Notice d'installation

it Istruzioni per l'installazione

zh 安装说明

es Instrucciones de instalación

ru инструкция по установке

pt Instruções de instalação

ko 설치 매뉴얼



IEC/EN 60947-4-1

UL 60947-4-1

CAN/CSA-C22.2 No. 60947-4-1



At the end of its life, this equipment should be collected separately from any unsorted municipal waste.



en ATTENTION! HAZARDOUS VOLTAGE!

The installation and the operation of this device and any maintenance must be carried out by a qualified person in accordance with specific local standards and safety regulations. Before installing this device, read these operating instructions carefully. Do not touch live parts. To avoid damages to persons and material the devices have to be replaced in case of mechanical and/or electrical damage.

de ACHTUNG! GEFÄHRLICHE SPANNUNG!

Die Installation und die Inbetriebnahme dieses Gerätes sowie jegliche Wartungsarbeiten müssen durch eine qualifizierte Fachkraft durchgeführt werden. Dabei sind lokale Normen und Sicherheitsvorschriften zu beachten. Vor der Installation des Gerätes muss diese Betriebsanleitung aufmerksam gelesen werden. Spannung führende Teile nicht berühren. Um Personen- und Sachschäden auszuschließen, müssen die Geräte im Fall einer mechanischen und/oder elektrischen Beschädigung unbedingt ausgetauscht werden.

fr DANGER! TENSION ÉLECTRIQUE DANGEREUSE!

L'installation et la mise en service de cet appareil ainsi que toute opération de maintenance doivent être réalisées par une personne qualifiée, dans le respect des normes locales et des dispositions en matière de sécurité. Avant d'installer cet appareil, lisez attentivement cette notice d'utilisation. Ne pas toucher les éléments sous tension. Afin d'éviter des dommages corporels et matériels, les appareils doivent être remplacés en cas de dommage mécanique et/ou électrique.

it ATTENZIONE! TENSIONE PERICOLOSA!

L'installazione e la messa in esercizio di questo apparecchio e tutti gli interventi di manutenzione dovranno essere eseguiti da tecnici qualificati, in osservazione delle norme di legge locali e delle disposizioni di sicurezza. Non toccare le parti in tensione! Per escludere lesioni a persone e danni materiali, sostituire gli apparecchi in caso di danneggiamento meccanico e/o elettrico.

zh 注意! 电压危险!

此设备的安装和运行以及任何保养工作必须由具备资格的专业人员进行，并遵守当地的有关标准和安全规则。在安装此设备前，请仔细阅读这些使用说明。不要触摸带电部件。为避免造成人员伤害和物质损坏，发生机械和/或电气损坏时必须更换设备。

es ¡ATENCIÓN! ¡TENSION PELIGROSA!

La instalación y la puesta en funcionamiento de este dispositivo, así como cualquier trabajo de mantenimiento, deberán ser ejecutados por una persona competente cualificada. En esto, deberán observarse las normas locales y las normas de seguridad. No tocar piezas que se encuentren bajo tensión. Para evitar daños personales y materiales, los dispositivos deberán ser sustituidos al presentar cualquier daño mecánico y/o eléctrico.

ru ВНИМАНИЕ! ОПАСНОЕ НАПРЯЖЕНИЕ!

Монтаж и ввод в эксплуатацию данного прибора, а также любые работы по техобслуживанию, должны производиться квалифицированными специалистами. При этом, необходимо соблюдать местные нормы и правила техники безопасности. Не прикасаться к деталям, которые находятся под напряжением. Чтобы исключить нанесение травм, а также материальные ущербы, в случае механических и/или электрических повреждений приборы необходимо заменить.

pt ATENÇÃO TENSÃO PERIGOSA!

A instalação e operação deste dispositivo e qualquer manutenção devem ser feitas por pessoal qualificado, de acordo com as normas locais e regulamentações de segurança. Antes de instalar este dispositivo, leia com atenção as instruções de operação. Não toque em peças energizadas. Para evitar danos a pessoas e materiais, os dispositivos devem ser substituídos em caso de dano mecânico e/ou elétrico.



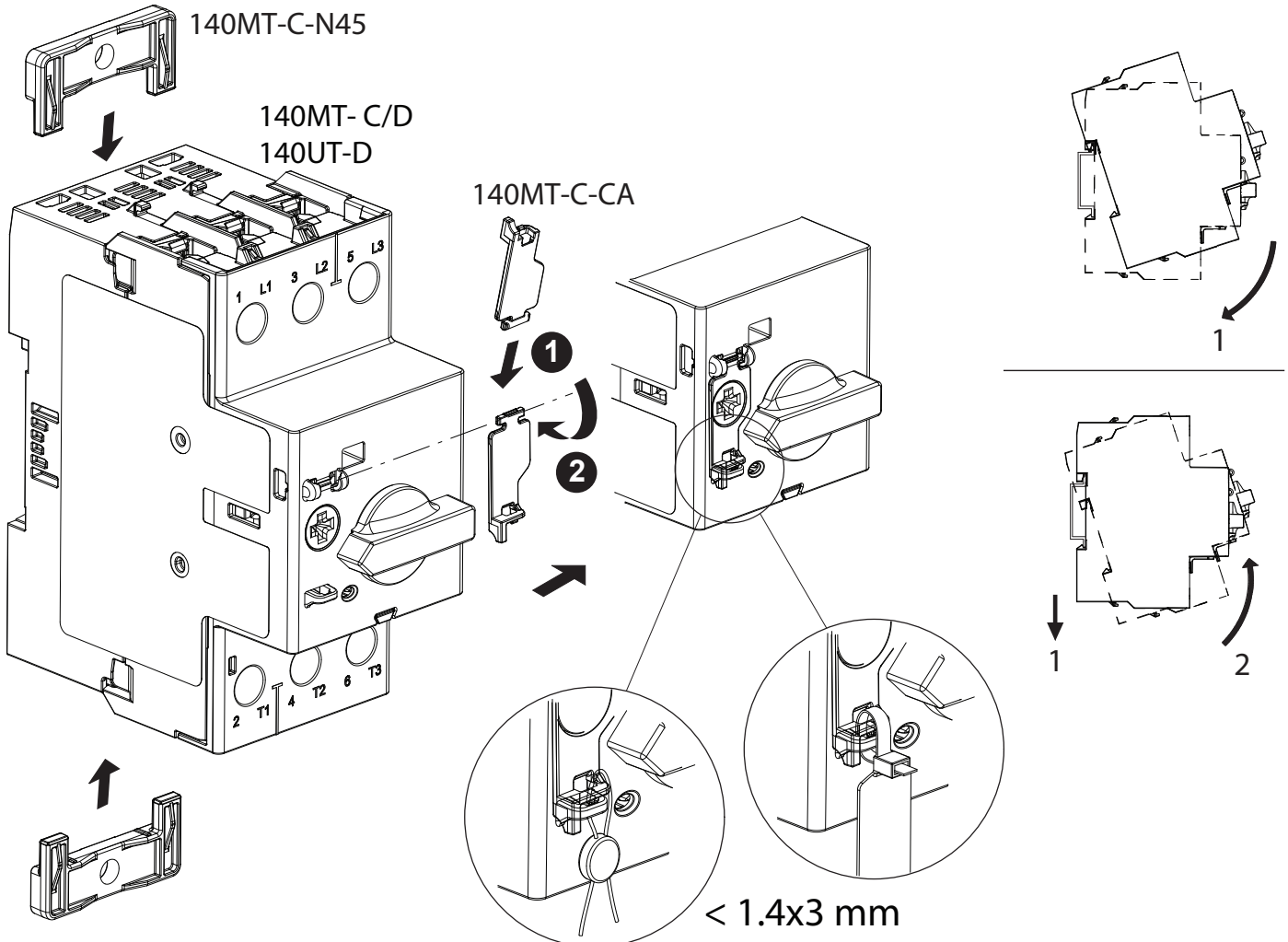

ko 주의 위험한 전압

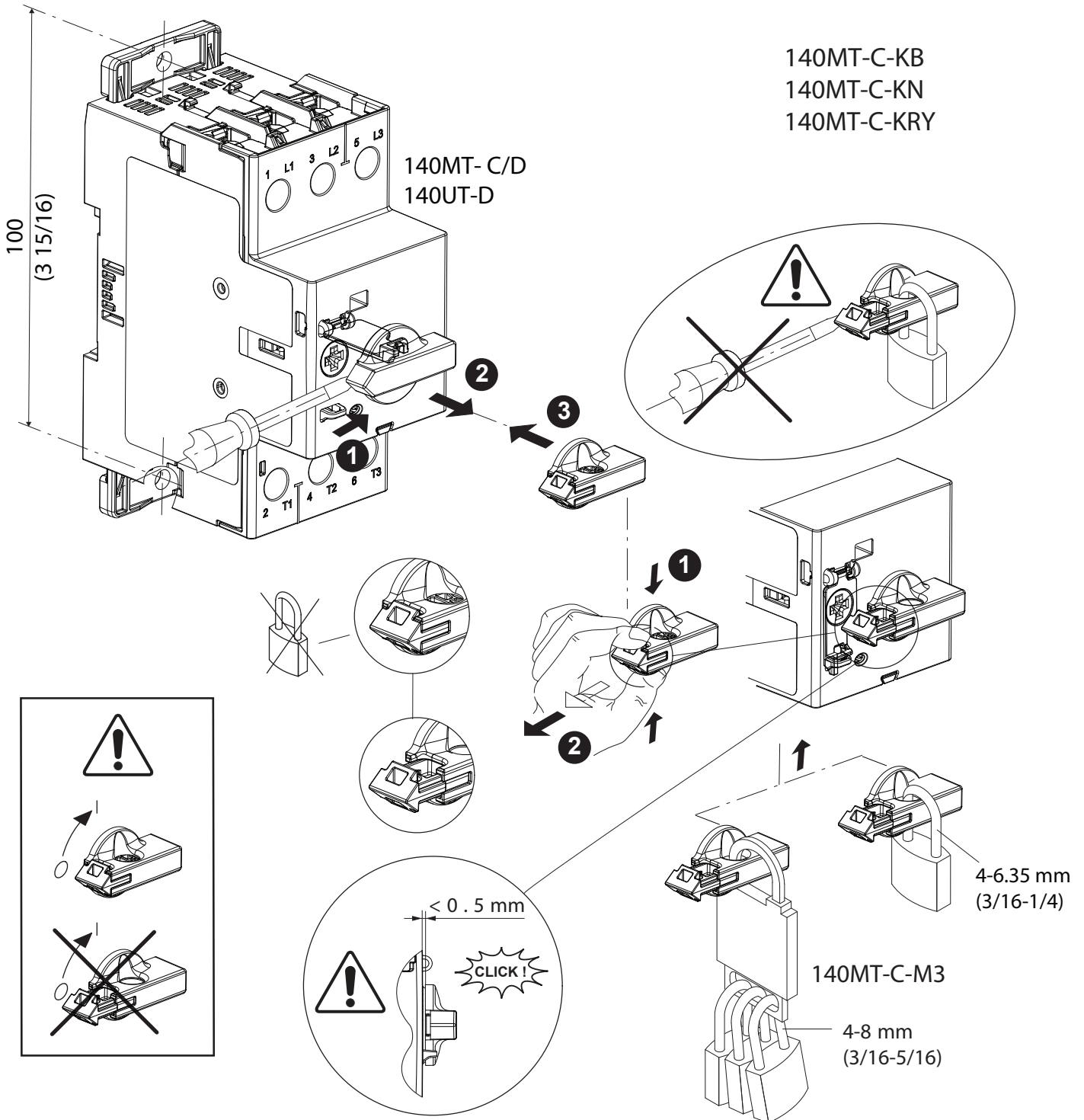
이 장치의 설치 및 작동과 유지 보수는 유자격 직원이 지역 표준 및 안전 규정에 따라 수행해야 합니다. 이 장치를 설치하기 전에, 사용자 매뉴얼을 주의 깊게 읽으십시오. 작동 중인 부품에 손을 대지 마십시오. 인적 및 물적 피해를 방지할 수 있도록 기계적 및/또는 전기적 손상이 발생하는 경우에 장치를 교체해야 합니다.





Attention! Not to be used as primary lockout-tagout device. An additional locking device may be required in the overall installation to comply with local standards and safety regulations.

Connect with us.    

For Technical Support, visit rok.auto/support.

Rockwell Automation maintains current product environmental compliance information on its website at rok.auto/pec.

Product certificates are located in the Rockwell Automation Literature Library: rok.auto/certifications.

Rockwell Otomasyon Ticaret A.Ş., Kar Plaza İş Merkezi E Blok Kat:6 34752 İçerenköy, İstanbul, Tel: +90 (216) 5698400

EEE Yönetmeliğine Uygundur.

rockwellautomation.com

expanding human possibility™

AMERICAS: Rockwell Automation, 1201 South Second Street, Milwaukee, WI 53204-2496 USA, Tel: 414.382.2000, Fax: (1) 414.382.4444

EUROPE/MIDDLE EAST/AFRICA: Rockwell Automation NV, Pegasus Park, De Kleetlan 12a, 1831 Diegem, Belgium, Tel: (32) 2663 0600, Fax: (32) 2663 0640

ASIA PACIFIC: Rockwell Automation, Level 14, Core F, Cyberport 3, 100 Cyberport Road, Hong Kong, Tel: (852) 2887 4788, Fax: (852) 2501846

Publication 140MT-IN005A-MU-P - March 2021

Copyright © 2021 Rockwell Automation, Inc. All Rights Reserved. Printed in USA.



PN-D177448

DIR 10005514158 (Version 00)