



Analog & Digital I/O Conversion Module

(Cat 1492-CM1771-LA004)

I. Description

This I/O Conversion Module provides for the conversion of (1) 1771, 8 Ch Analog I/O module to be converted to (1) or (2) 1756, 6 Ch Analog I/O module(s) and consists of the following:

(1) 1771 I/O Module (8ch) to (1) 1756 I/O Module (6ch)

(1) Conversion Module: 1492-CM1771-LA004

(1) Cable: 1492-CONACAB005F or 1492-CONACAB005K or 1492-CONACAB005L (Table 2)

(1) Conversion Mounting Assembly: 1492-MUA... (Table 1)

(1) 1771 I/O Module (8ch) to (2) 1756 I/O Modules (6ch) - (4ch) on each 1756 I/O Module

(1) Conversion Module(s): 1492-CM1771-LA004

(1) Cable: 1492-CONACAB005T1 or 1492-CONACAB005T2 (Table 2)

(1) Conversion Mounting Assembly: 1492-MUA... (Table 1)

This I/O Conversion Module also provides for the conversion of (2) 1771 Digital I/O modules that also use the 1771-WF swing arm. In this case, this I/O conversion modules provide for the conversion of (2) 1771, 8 pt. Digital I/O modules to be converted to (1) 1756, 16 pt. Digital I/O module and consists of the following:

(2) 1771 Module (8pt) to (1) 1756 Module (16pt)

(2) Conversion Modules: 1492-CM1771-LA004

(1) Cable: 1492-C005005XT (Table 2)

(1) Conversion Mounting Assembly: 1492-MUA... (Table 1)

These conversions are accomplished without the removal of any field wires from the existing 1771 Swing Arms. The existing 1771 Swing Arms fit directly onto the edge connector of the 1492 Conversion Modules. On one end of the 1492 Cable are (2) connectors for the Conversion Modules and on the other end is (1) Removable Terminal Block (RTB) for the 1756 I/O module. See the photos below.

The I/O signals are routed through the 1492 Conversion Module(s) and the 1492 Cable(s) to the appropriate terminals on the 1756 I/O module(s) per the Wiring Diagrams in Section V. As standard, the 1492 Cables are 0.5M long, but we also offer a 1.0M cable length. Refer to the footnotes in Table 2 for further details.



WARNING

De-energize and lockout any and all power to all I/O field devices connected to the A-B 1771 I/O chassis, and the power to the 1771 I/O chassis itself. Ensure all power is de-energized and locked out to any device in the control cabinet where the conversion is to be performed. Ensure work is performed by qualified personnel.

I. Description (Cont'd)

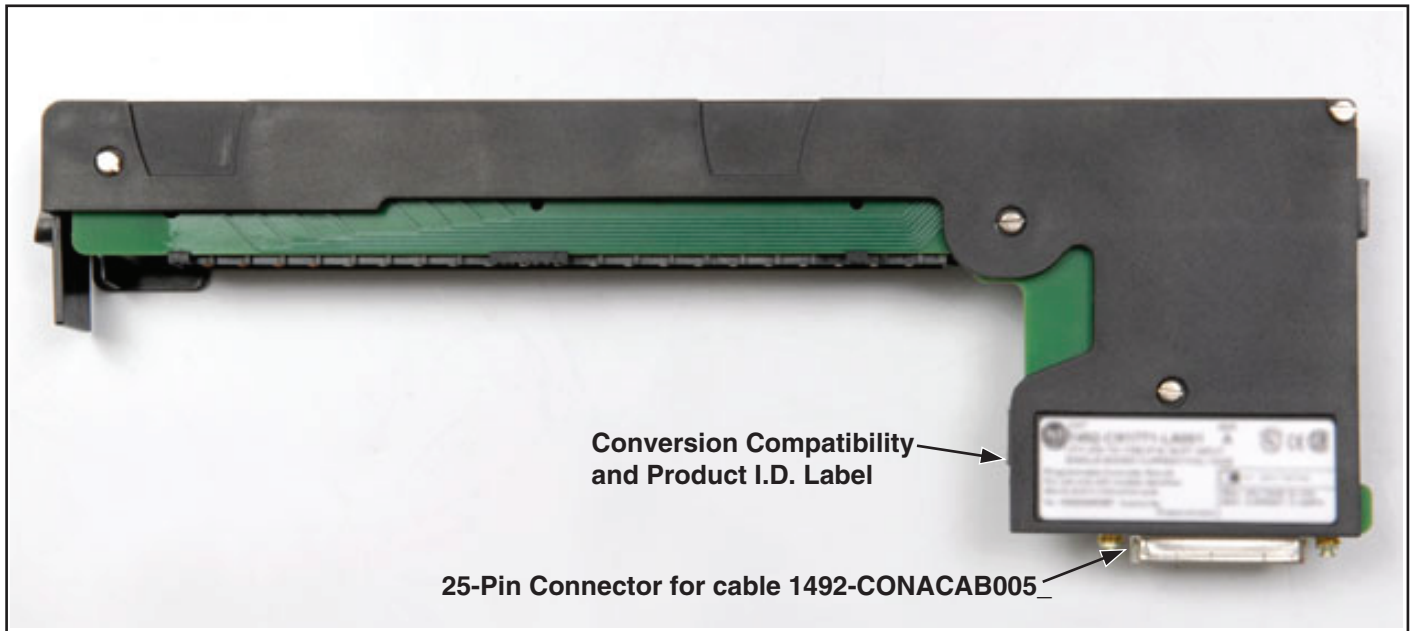

1492-CM1771-LA004 Conversion Module

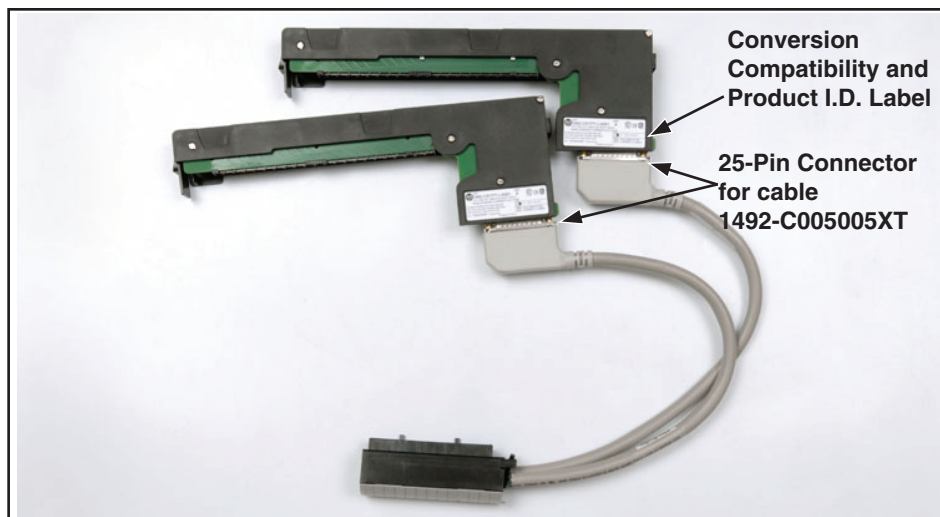
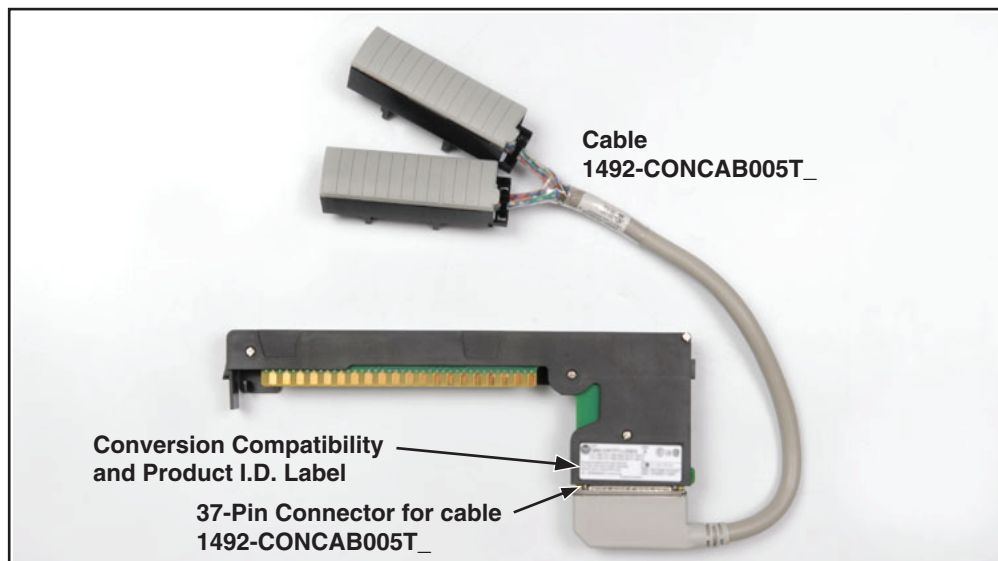

II. Installation

The 1492 Conversion Modules must be installed in a 1492 Conversion Mounting Assembly (see Table 1 below). A complete System Installation Manual ships with the 1492 Conversion Mounting Assembly.

- 1) Determine the quantity of each type of 1771 I/O modules used in the 1771 I/O Chassis to be converted.
- 2) Select the applicable 1492 Conversion Modules from Table 2, Section III.
- 3) Review the Max Slots for I/O and Chassis Width data from the Table 1 below.
- 4) Select a 1756 I/O Chassis which has enough I/O Slots.

NOTE: (2) I/O slots are required in the 1756 Chassis for conversions where (1) 1771 I/O module converts to (2) 1756 I/O modules.

- 5) Select the 1492 Conversion Mounting Assembly which has enough Conversion Module slots.

NOTE: (2) Conversion Module slots are required in the 1492 Conversion Mounting Assembly for conversions where (2) 1771 I/O module convert to (1) 1756 I/O modules.

NOTE: The 1492 Conversion Mounting Assembly has the same Height & Width foot-print as the 1771 Chassis and is designed to use the same mounting hardware. The combined Depth of the 1492 Conversion Mounting Assembly with the 1756 Chassis mounted on top is 10.25 inches (Controller w/key) or 10.0 inches (Controller w/o key). Dimension drawings are included in the System Installation Manual that ships with the 1492 Conversion Mounting Assembly.

Table 1: Bulletin 1771 to 1756 Chassis Conversion

1771 Chassis				1756 Chassis			Conversion Mounting Assembly		
Cat. No.	Max Slots for I/O	Chassis Width ^②		Cat. No.	Max Slots for I/O	Chassis Width	Cat. No.	Max Slots for Conversion Modules	Chassis Width
		without Power Supply	with Power Supply						
1771-A1B	4	9.01	12.61	1756-A4	3	10.35	1492-MUA1B-A4-A7	4	9.01
				1756-A7	6	14.49			
1771-A2B	8	14.01	17.61	1756-A7	6	14.49	1492-MUA2B-A7-A10	8	14.01
				1756-A10	9	19.02			
1771-A3B1 ^①	12	19.01		1756-A10	9	19.02	1492-MUA3-A10-A13	12	19.01
				1756-A13	12	23.15			
1771-A4B	16	24.01		1756-A13	12	23.15	1492-MUA4-A13-A17	16	24.01
				1756-A17	16	29.06			

Foot Notes:

^① 1771-A3B is not listed as it is used for 19 inch wide instrumentation panels.

^② Notice that the 1756 Chassis Width sometimes exceeds the 1771 Chassis Width, with or without the Power Supply. The Cover-Plate of the 1492 Conversion Mounting Assembly allows the 1756 Chassis to be Left justified, Right justified or Centered. A complete System Installation Manual ships with the 1492 Conversion Mounting Assembly.

III. Compatibility

1771 Analog I/O Module ^①	1756 Analog I/O Module ^①	1492 I/O Conversion Module	1492 Cable
1771-IL	1756-IF6I (6 ch Current)	1492-CM1771-LA004	1492-CONACAB005K ^②
1771-IL	1756-IF6I (6 ch Voltage)	1492-CM1771-LA004	1492-CONACAB005L ^②
1771-IL	1756-IF6I (6 ch Current) (Qty 2)	1492-CM1771-LA004	1492-CONACAB005T1 ^②
1771-IL	1756-IF6I (6 ch Voltage) (Qty 2)	1492-CM1771-LA004	1492-CONACAB005T2 ^②
1771-IR	1756-IR6I	1492-CM1771-LA004	1492-CONACAB005F ^②
1771-OQ (Qty 2) (Digital)	1756-OB16I	1492-CM1771-LA004	1492-C005005XT ^③

Foot Notes:

- ① To understand any issues concerning I/O module compatibility, refer to the Installation Manuals for the specific 1771 and 1756 I/O modules involved.
- ② The 3 numbers indicate the length of the 1492 Cable. Recommended cable lengths of 0.5M are shown. Additional cable lengths are as follows:
 1.0M = 1492-CONACAB010F or 1492-CONACAB010K or 1492-CONACAB010L
 1.0M = 1492-CONACAB010T1 or 1492-CONACAB010T2
- ③ The 6 numbers indicate the cable length of each portion of the 1492 Cable. Recommended cable lengths of 0.5M / 0.5M are shown. Additional cable lengths are as follows:
 1.0M / 1.0M = 1492-C010010XT
 0.5M / 1.0M = 1492-C005010XT
 1.0M / 0.5M = 1492-C010005XT

IV. Conversion Module Specifications

(Operating specifications are when installed in the Conversion System base / cover-plate assembly)

Specification	Value
Dimensions	11.81 in. (height) x 4.38 in. (depth) x 1.5 in. (width) 300 mm. (height) x 111.25 mm (depth) x 38.1 mm (width)
Approximate Shipping Weight	250.6 g (0.55 lbs) (includes carton)
Storage Temperature	-40 to +85 C (-40 to 185° F)
Operating Temperature	0 to 60 C (32 to 40° F)
Operating Humidity	5 to 95% at 60° C (non-condensing)
Shock	
Non-operating	50g
Operating	30g
Operating Vibration	2g at 10 to 500Hz (Agrees with 1756 I/O module specification)
Maximum Operating Voltage	30 Vdc
Max. Module Operating Current	
Per Point:	2 Amps
Per Module:	12 Amps
	NOTICE Refer to the Wiring Diagram(s) for current limits for a specific configuration.
Agency Certifications	UL Classified: Under UL File Number E113724 CSA CE: compliant for all applicable directives
Pollution Degree	2
Environmental Rating	IP20



WARNING

There are several key application considerations and system specifications (bottom of drawing) when using these components (conversion module, cable and input module). Read and understand these considerations before installation.

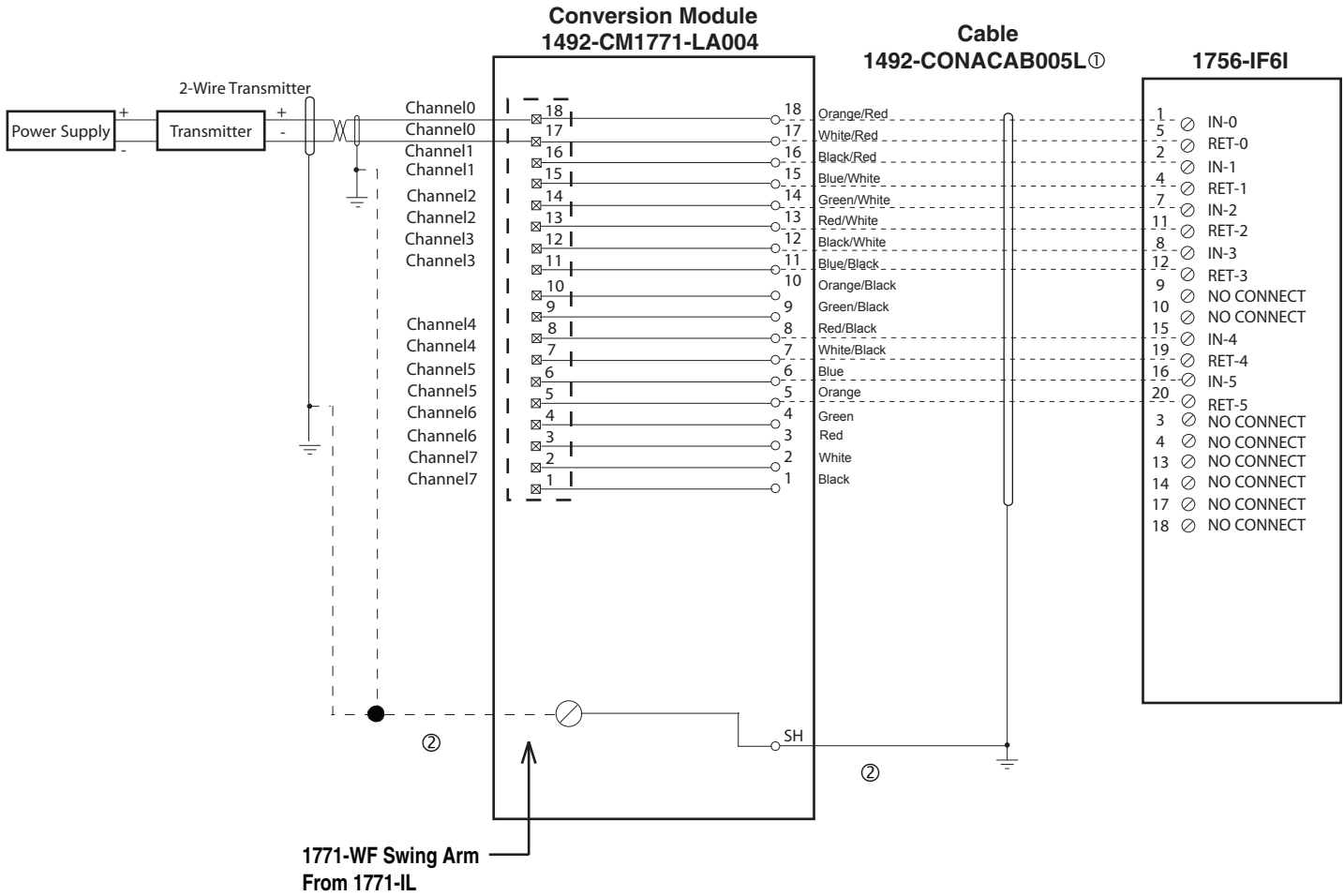

Conversion Module Installation and Application Considerations

① This Bul. 1492 cable consists of a cable wired to one 1756-IF6I RTB. Recommended cable lengths of 0.5M or 1.0M (005=0.5M, 010=1.0M). See table 2 for other lengths.

② SHIELD GROUNDING: In some installations, the field wiring shield was grounded on the 1771 chassis. If this was the case, the installer must remove these shield connections from the 1771 chassis and they can be connected to the grounding stud on the 1492-CM1771-LA004 module. The pre-wired cable used between the 1492-CM1771-LA004 module and the 1756-IF6I [1492-CONACAB005L] provides a shield ground lug to ground the shield at the 1756 ControlLogix chassis, this must be connected. Do NOT connect this ground lug to the conversion module grounding stud.

③ The 1771-IL input configuration was software configured, as is the 1756-IF6I. Please ensure the correct configuration in the 1756-IF6I.

④ Refer to your 1771-IL and 1756-IF6I Installation and User Manuals for additional information concerning comparisons of module wiring, features and configuration details. [Reference Doc: 41171-029 (Version 00)]



WARNING

There are several key application considerations and system specifications (bottom of drawing) when using these components (conversion module, cable and input module). Read and understand these considerations before installation.

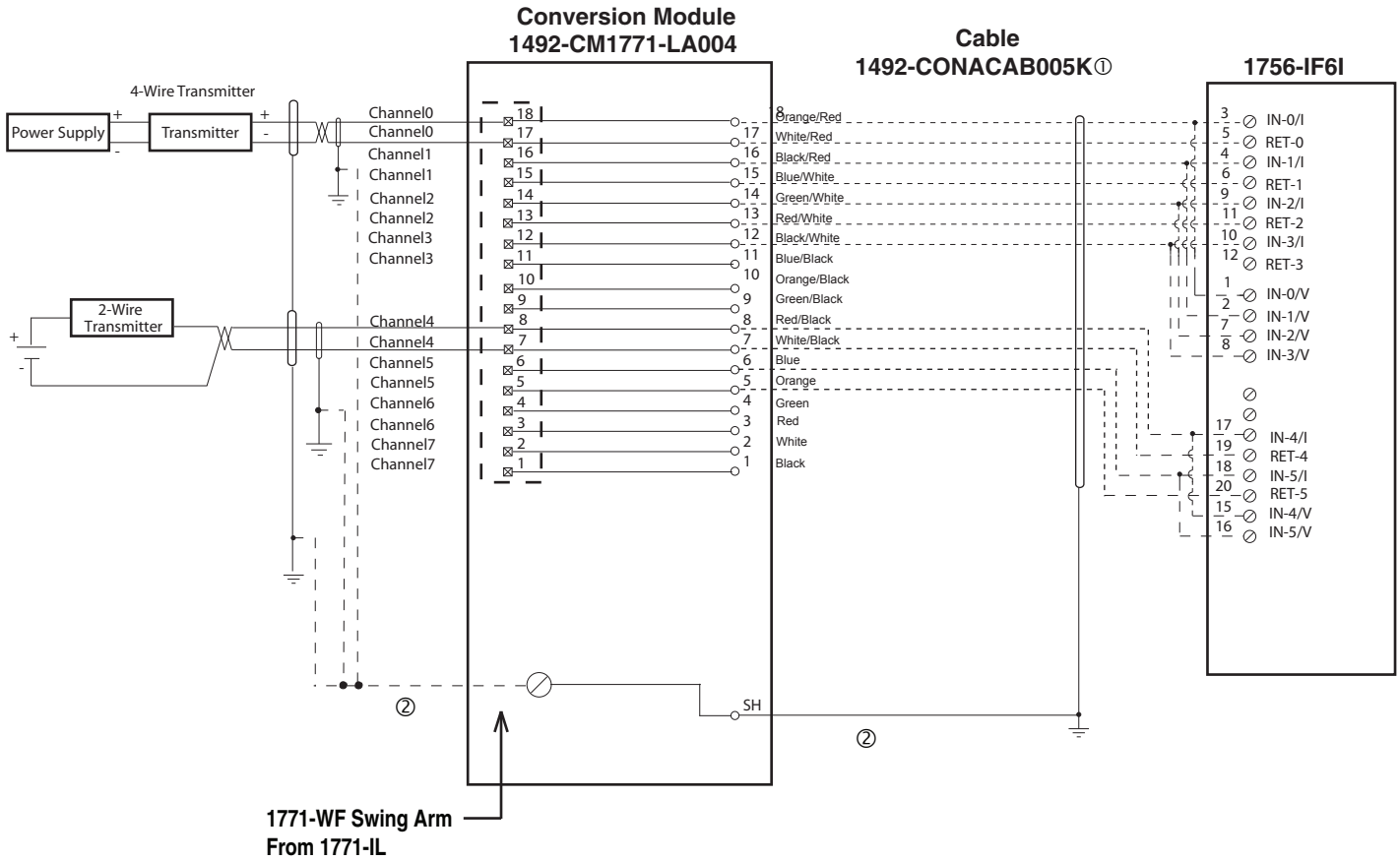

Conversion Module Installation and Application Considerations

- ① This Bul. 1492 cable consists of a cable wired to one 1756-IF6I RTB. Recommended cable lengths of 0.5M or 1.0M (005=0.5M, 010=1.0M). See table 2 for other lengths.
- ② SHIELD GROUNDING: In some installations, the field wiring shield was grounded on the 1771 chassis. If this was the case, the installer must remove these shield connections from the 1771 chassis and they can be connected to the grounding stud on the 1492-CM1771-LA004 module. The pre-wired cable used between the 1492-CM1771-LA004 module and the 1756-IF6I [1492-CONACAB005K] provides a shield ground lug to ground the shield at the 1756 ControlLogix chassis, this must be connected. Do NOT connect this ground lug to the conversion module grounding stud.
- ③ The 1771-IL input configuration was software configured, as is the 1756-IF6I. Please ensure the correct configuration in the 1756-IF6I.
- ④ Refer to your 1771-IL and 1756-IF6I Installation and User Manuals for additional information concerning comparisons of module wiring, features and configuration details. [Reference Doc: 41171-030 (Version 00)]



WARNING

There are several key application considerations and system specifications (bottom of drawing) when using these components (conversion module, cable and input module). Read and understand these considerations before installation.

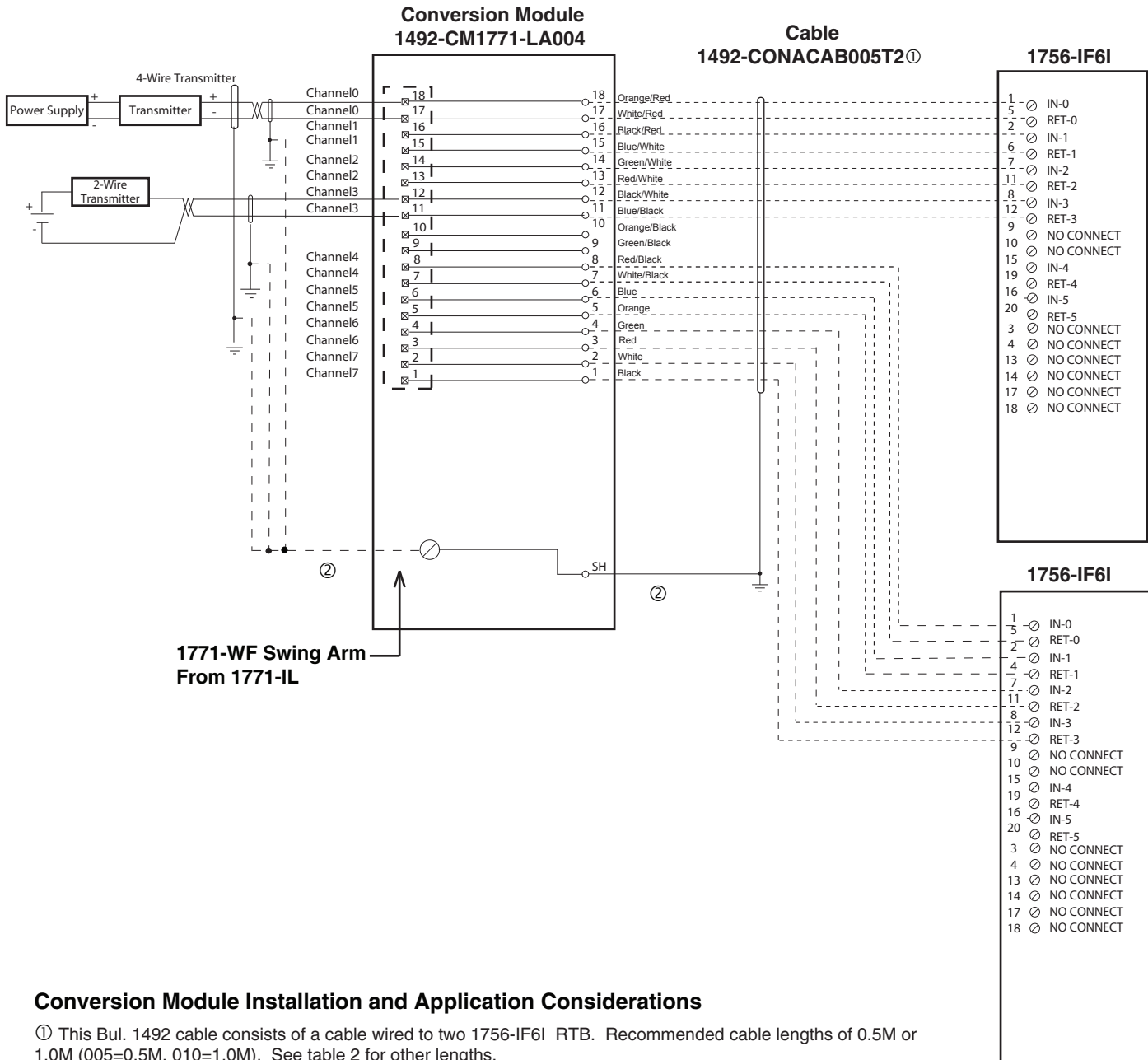

Conversion Module Installation and Application Considerations

- ① This Bul. 1492 cable consists of a cable wired to two 1756-IF6I RTB. Recommended cable lengths of 0.5M or 1.0M (005=0.5M, 010=1.0M). See table 2 for other lengths.
- ② SHIELD GROUNDING: In some installations, the field wiring shield was grounded on the 1771 chassis. If this was the case, the installer must remove these shield connections from the 1771 chassis and they can be connected to the grounding stud on the 1492-CM1771-LA004 module. The pre-wired cable used between the 1492-CM1771-LA004 module and the 1756-IF6I [1492-CONACAB005T2] provides a shield ground lug to ground the shield at the 1756 ControlLogix chassis, this must be connected. Do NOT connect this ground lug to the conversion module grounding stud.
- ③ The 1771-IL input configuration was software configured, as is the 1756-IF6I. Please ensure the correct configuration in the 1756-IF6I.
- ④ Refer to your 1771-IL and 1756-IF6I Installation and User Manuals for additional information concerning comparisons of module wiring, features and configuration details.
- ⑤ This configuration uses two (2) 1756-IF6I output modules to replace a single 1771-IL output module. This may require the use of a larger 1756 I/O chassis and conversion mounting assembly. Ensure there is sufficient panel space to allow for this possibility.

[Reference Doc: 41171-031 (Version 00)]

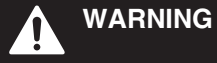

WARNING

There are several key application considerations and system specifications (bottom of drawing) when using these components (conversion module, cable and input module). Read and understand these considerations before installation.

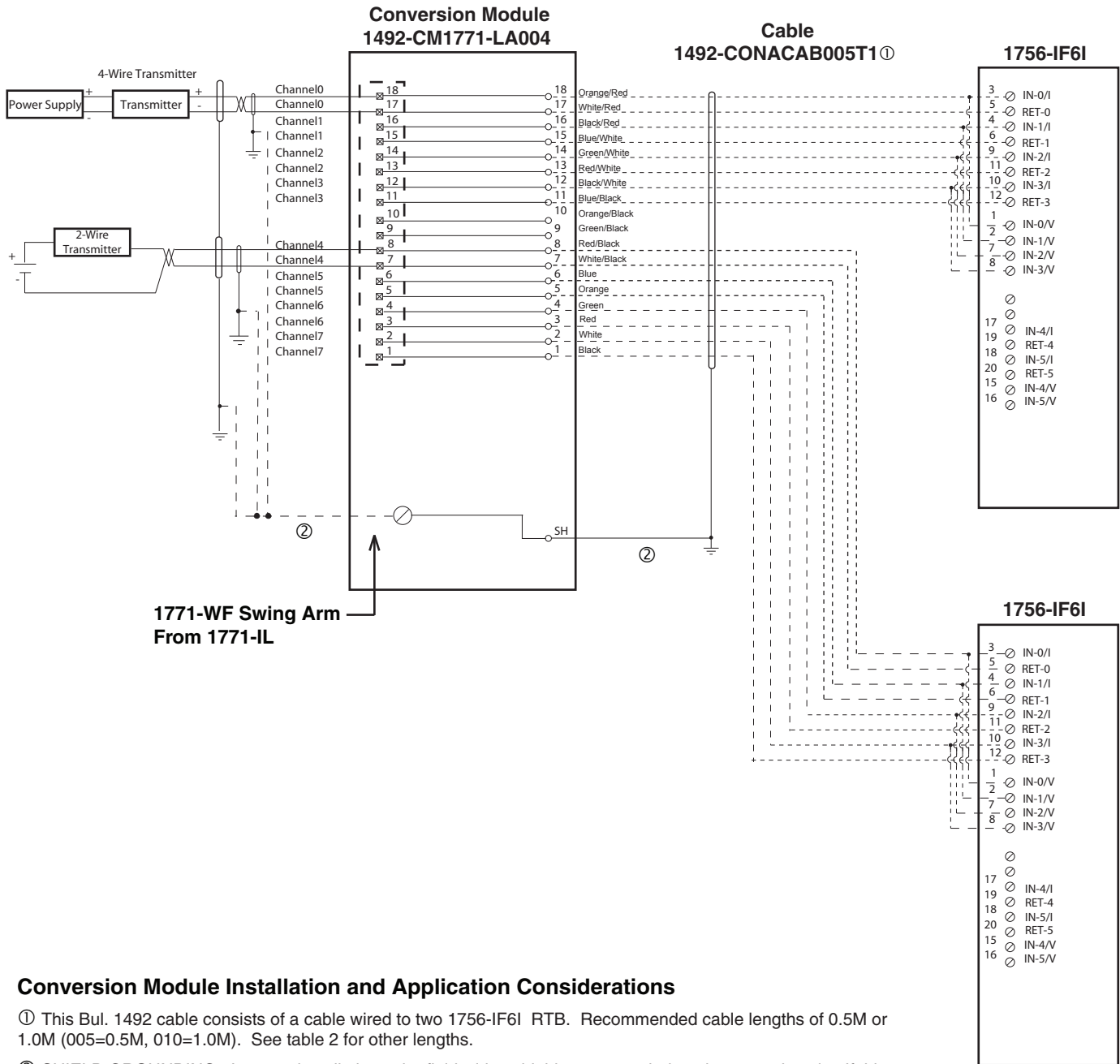

Conversion Module Installation and Application Considerations

- ① This Bul. 1492 cable consists of a cable wired to two 1756-IF6I RTB. Recommended cable lengths of 0.5M or 1.0M (005=0.5M, 010=1.0M). See table 2 for other lengths.
- ② SHIELD GROUNDING: In some installations, the field wiring shield was grounded on the 1771 chassis. If this was the case, the installer must remove these shield connections from the 1771 chassis and they can be connected to the grounding stud on the 1492-CM1771-LA004 module. The pre-wired cable used between the 1492-CM1771-LA004 module and the 1756-IF6I [1492-CONACAB005T1] provides a shield ground lug to ground the shield at the 1756 ControlLogix chassis, this must be connected. Do NOT connect this ground lug to the conversion module grounding stud.
- ③ The 1771-IL input configuration was software configured, as is the 1756-IF6I. Please ensure the correct configuration in the 1756-IF6I.
- ④ Refer to your 1771-IL and 1756-IF6I Installation and User Manuals for additional information concerning comparisons of module wiring, features and configuration details.
- ⑤ This configuration uses two (2) 1756-IF6I output modules to replace a single 1771-IL output module. This may require the use of a larger 1756 I/O chassis and conversion mounting assembly. Ensure there is sufficient panel space to allow for this possibility.

[Reference Doc: 41171-032 (Version 00)]



WARNING

There are several key application considerations and system specifications (bottom of drawing) when using these components (conversion module, cable and input module). Read and understand these considerations before installation.

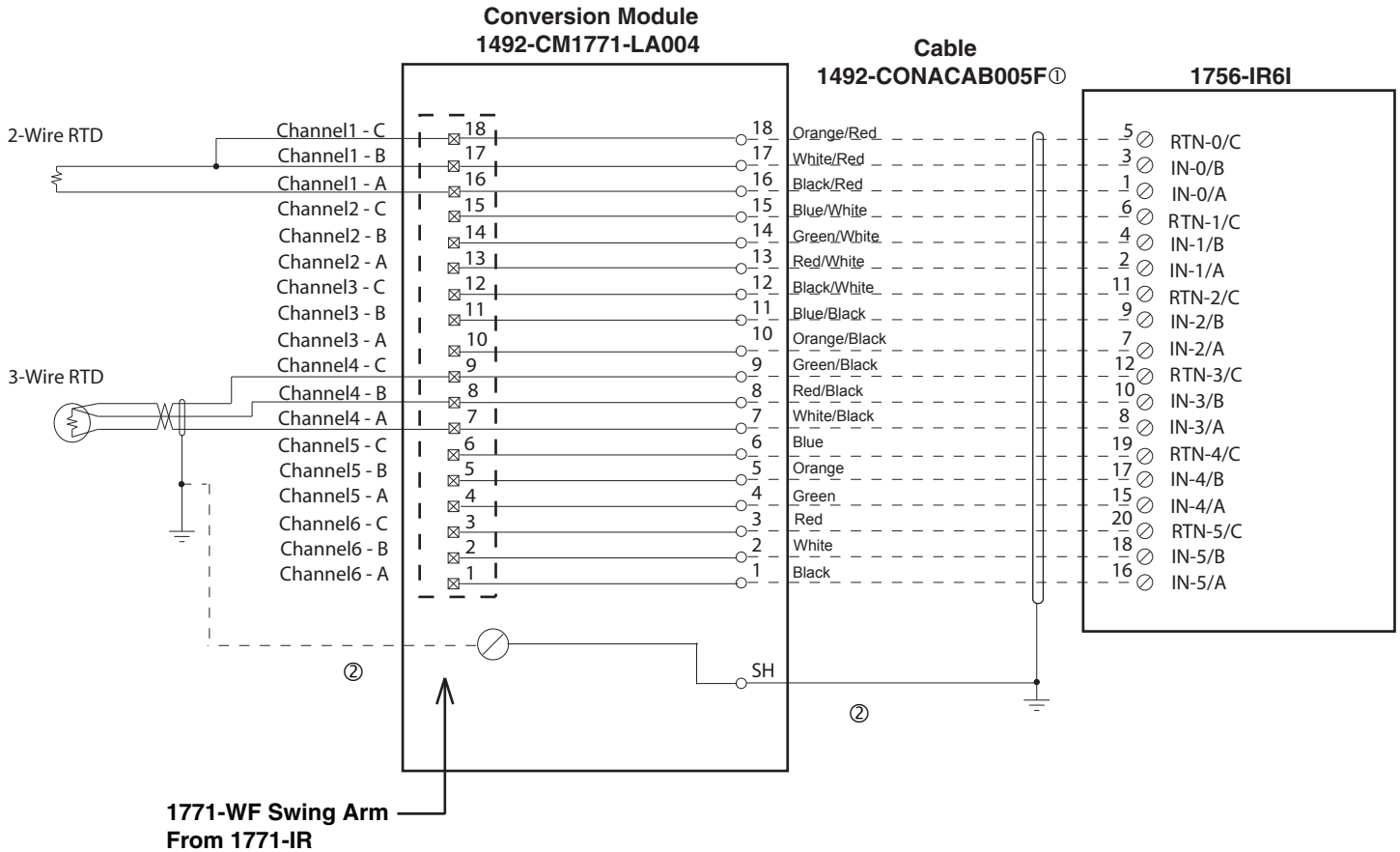

Conversion Module Installation and Application Considerations

- ① This Bul. 1492 cable consists of a cable wired to one 1756-IR6I RTB. Recommended cable lengths of 0.5M or 1.0M (005=0.5M, 010=1.0M). See table 2 for other lengths.
- ② **SHIELD GROUNDING:** In some installations, the field wiring shield was grounded on the 1771 chassis. If this was the case, the installer must remove these shield connections from the 1771 chassis and they can be connected to the grounding stud on the 1492-CM1771-LA004 module. The pre-wired cable used between the 1492-CM1771-LA004 module and the 1756-IR6I [1492-CONACAB005F] provides a shield ground lug to ground the shield at the 1756 ControlLogix chassis, this must be connected. Do NOT connect this ground lug to the conversion module grounding stud.
- ③ The 1771-IR input configuration was software configured, as is the 1756-IR6I. Please ensure the correct configuration in the 1756-IR6I.
- ④ Refer to your 1771-IR and 1756-IR6I Installation and User Manuals for additional information concerning comparisons of module wiring, features and configuration details. [Reference Doc: 41170-950 (Version 02)]



WARNING

There are several key application considerations and system specifications (bottom of drawing) when using these components (conversion module, cable and input module). Read and understand these considerations before installation.

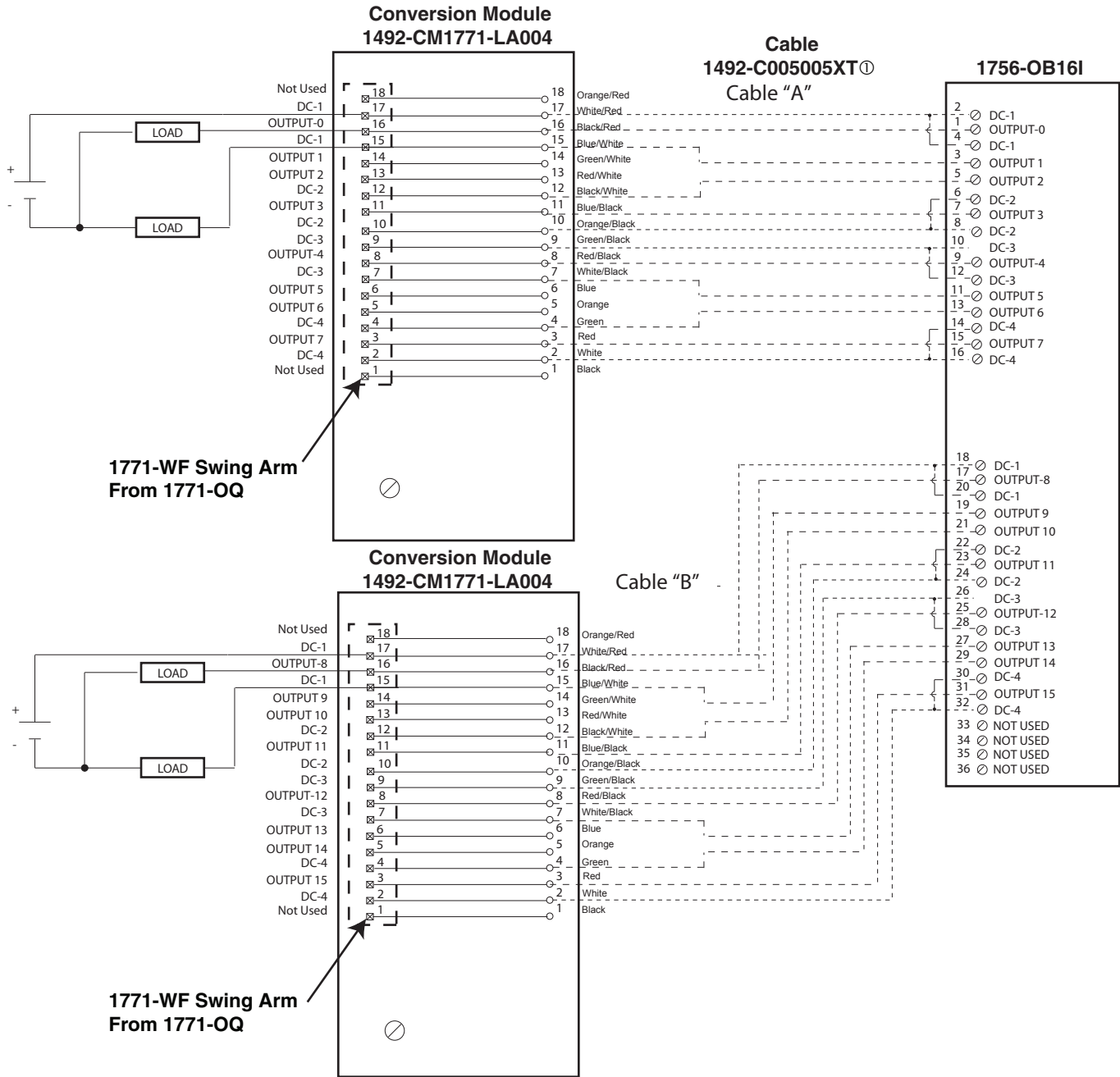

Conversion Module Installation and Application Considerations

- ① This Bul. 1492 cable consists of 2 separate cables (cable "A" and cable "B") wired to one 1756-OB16I RTB. Each cable can be either 0.5M or 1.0M (005=0.5M, 010=1.0M). Ensure that cable A and cable B are connected to the correct module in the conversion
- ② The 1771-OQ module output resistive current limits versus 1756-OB16I limits are as follows:

	1771-OQ	1756-OB16I w/ 1492-C005005XT
a) Current/Point	2.25A	2A
b) Current/Module	9A	8A
c) Surge Current/Point	4A for 10ms	4A for 10ms
- ③ The 1771-OQ is rated 10V to 32V DC. The 1756-OB16I is rated 10V to 30V DC.
- ④ Refer to your 1771-OQ and 1756-OB16I Installation Manual wiring schematics and diagrams for more details. Ensure 1756 output module ratings are not exceeded. [Reference Doc: 41171-033 (Version 00)]

