

CRITICAL TO QUALITY CLASSIFICATION TABLE					
P=PERFORMANCE, F=FIT, A=ASSEMBLY X=IDENTIFIES APPLICABLE CLASSIFICATION(S) ⊖=ENGINEERING AND/OR MANUFACTURING REQUIREMENT Ⓢ=REGULATORY REQUIREMENT-CONFORMANCE IS MANDATORY					
COMMENTS	DRAWING ZONE	P	F	A	R
ROHS	GI-HI				X

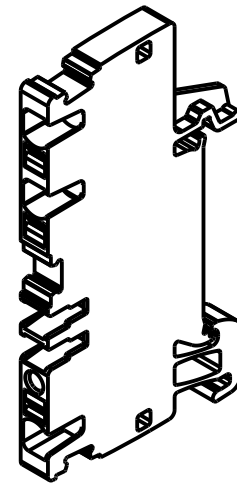

MUST COMPLY WITH ROCKWELL
 AUTOMATION ENVIRONMENTAL
 SPECIFICATION 970-20-01

ALL UNDIMENSIONED
 GEOMETRIES ARE
 CONTROLLED BY THE
 CAD MODEL. IN CASE
 OF DIMENSION
 DISCREPANCY, CAD
 MODEL OVERRIDES.

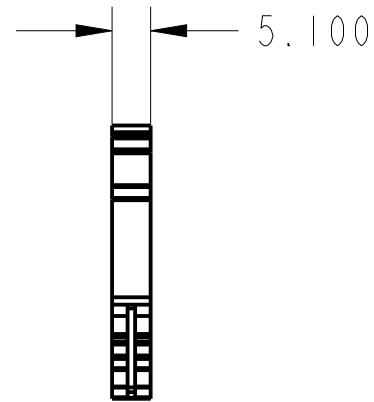
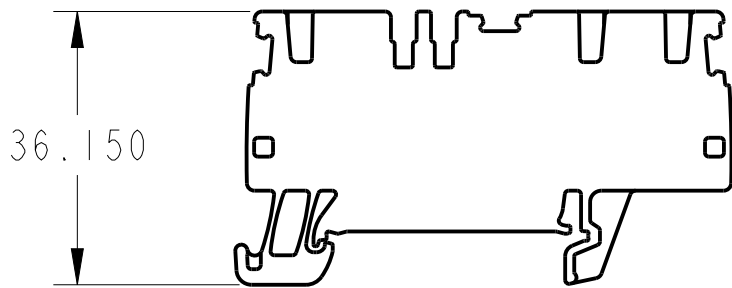

**Rockwell
Automation**

CONFIDENTIAL AND PROPRIETARY INFORMATION.
 THIS DOCUMENT CONTAINS CONFIDENTIAL AND PROPRIETARY
 INFORMATION OF ROCKWELL AUTOMATION, INC. AND MAY
 NOT BE USED, COPIED OR DISCLOSED TO OTHERS, EXCEPT
 WITH THE AUTHORIZED WRITTEN PERMISSION OF ROCKWELL
 AUTOMATION, INC.

THIRD ANGLE PROJECTION

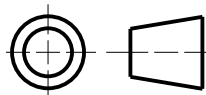

DESCRIPTION

1492-p3t.drw

DATE: 2019-08-09

SHEET 1 OF 1

SIZE

DIR

VER

A

01

CREATED BY: LYANG26

CHANGED BY: