

1 2 3 4 5 6 7 8

A
B
C
D
E
F
G
H

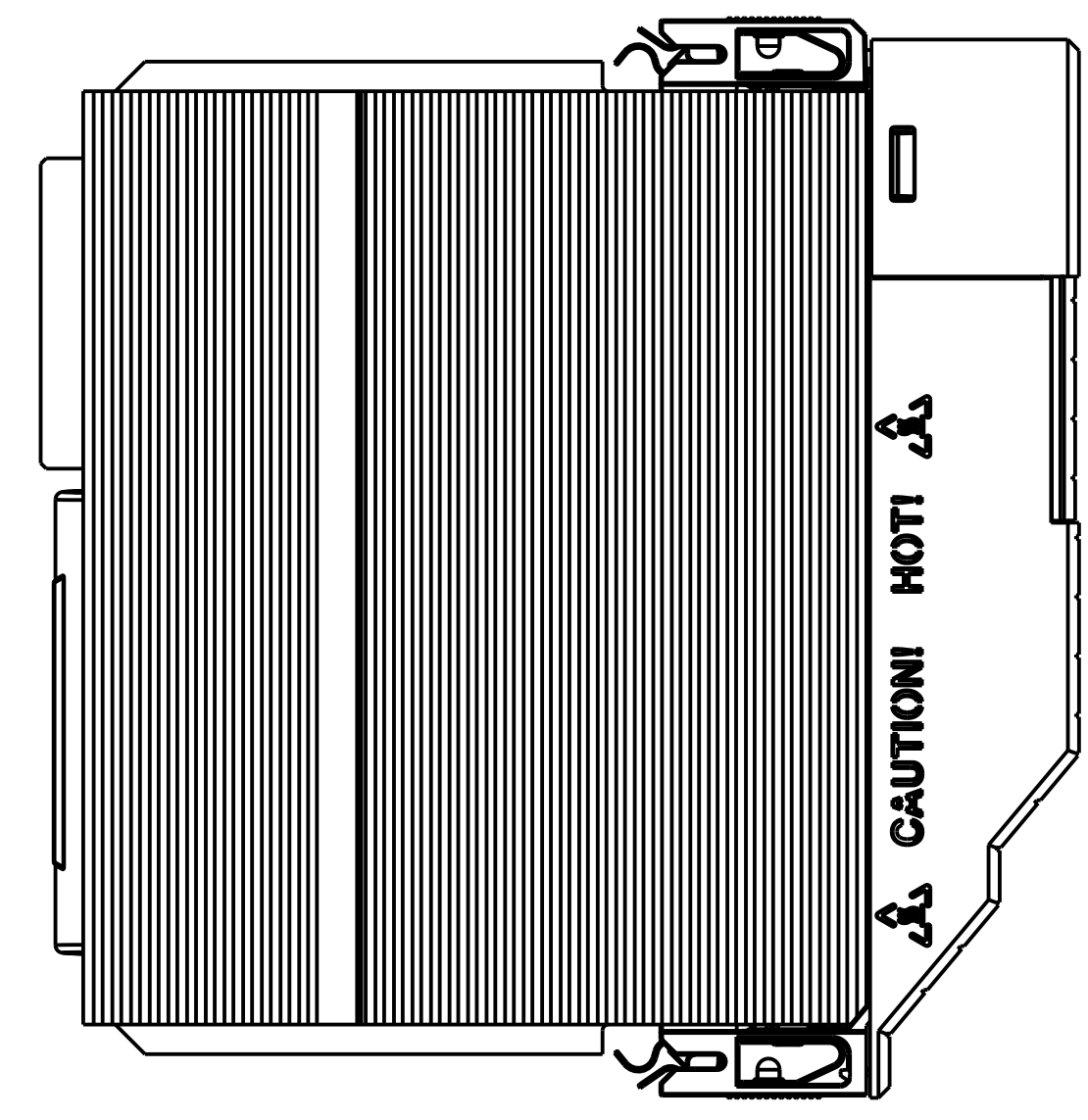
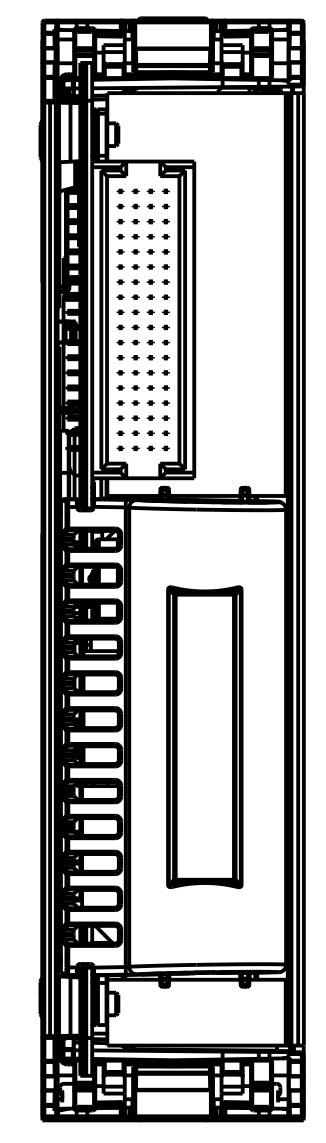
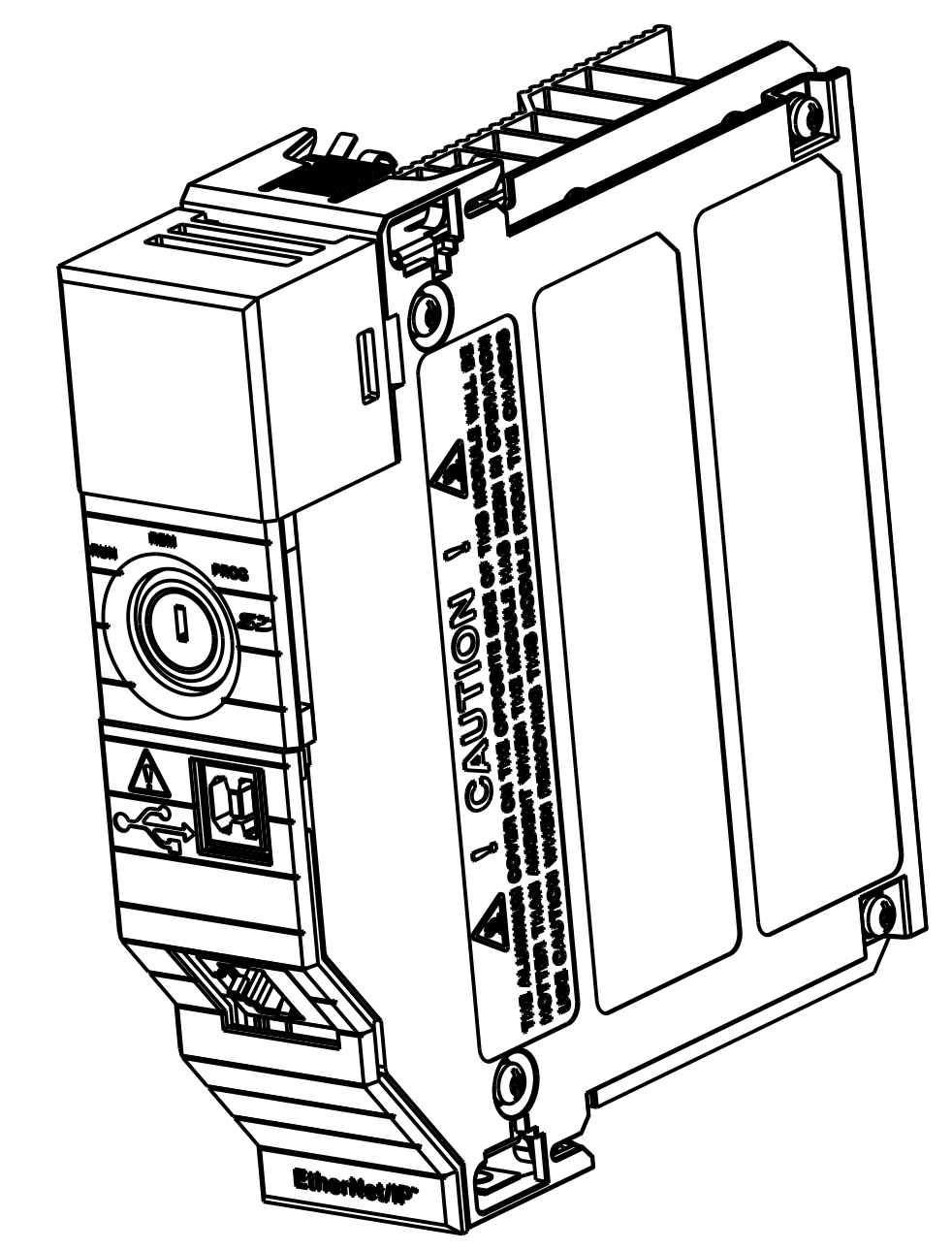
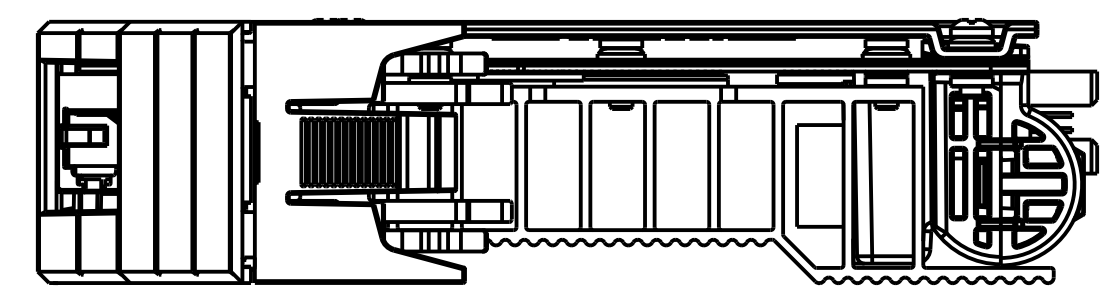
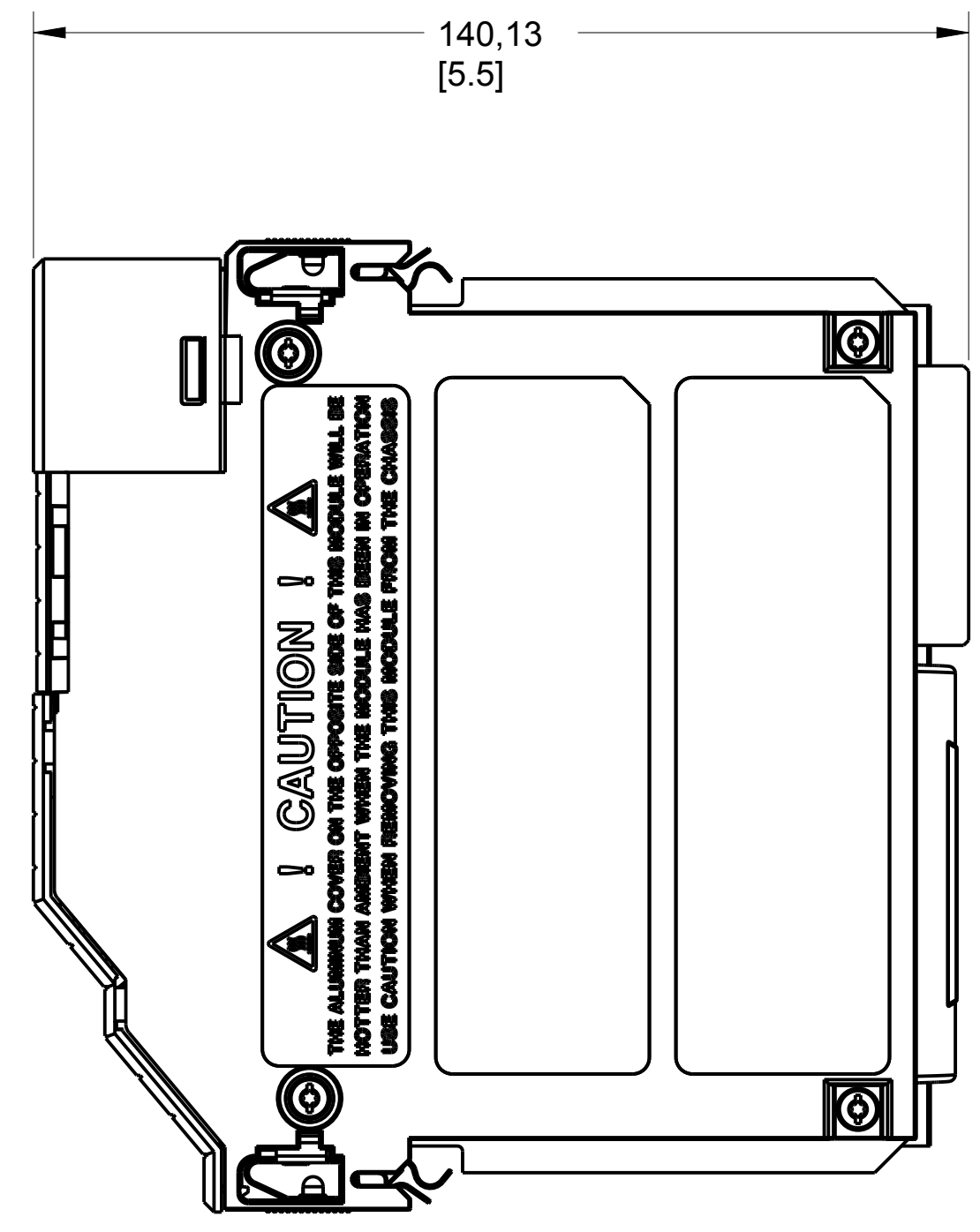
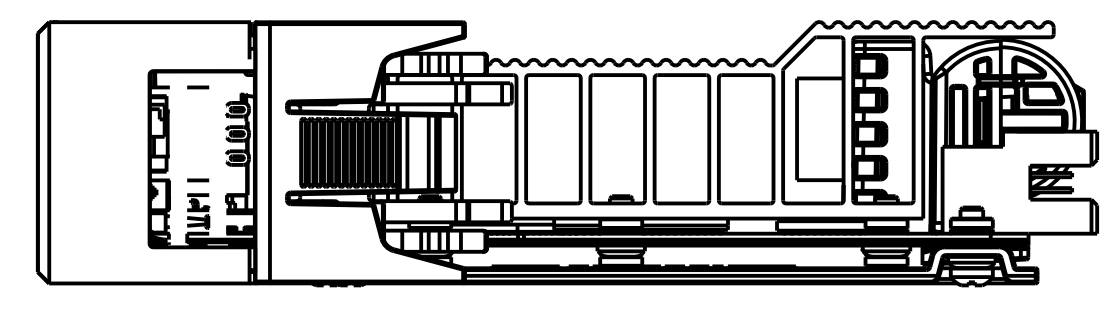
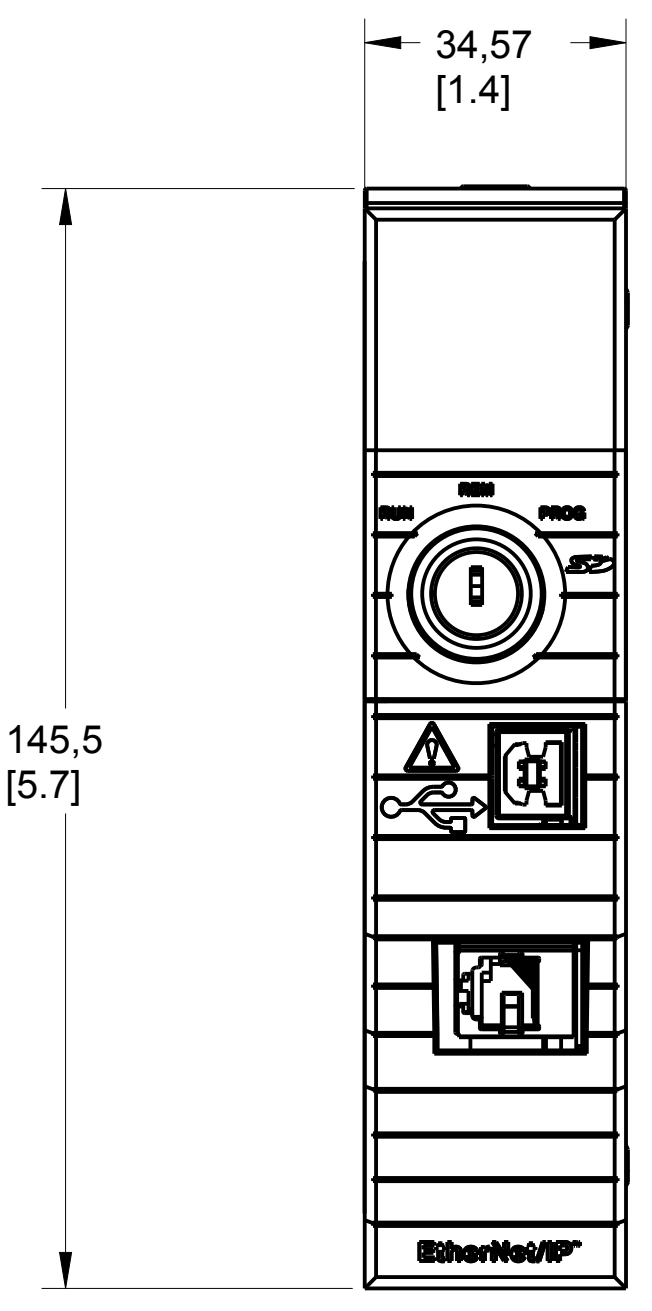

<p>ALL UNDIMENSIONED GEOMETRIES ARE CONTROLLED BY THE CAD MODEL. IN CASE OF DIMENSION DISCREPANCY, CAD MODEL OVERRIDES.</p>		<p>Rockwell Automation</p>		<p>CONFIDENTIAL AND PROPRIETARY INFORMATION. THIS DOCUMENT CONTAINS CONFIDENTIAL AND PROPRIETARY INFORMATION OF ROCKWELL AUTOMATION, INC. AND MAY NOT BE USED, COPIED OR DISCLOSED TO OTHERS, EXCEPT WITH THE AUTHORIZED WRITTEN PERMISSION OF ROCKWELL AUTOMATION, INC.</p>	
<p>FIRST ANGLE PROJECTION</p>		<p>DESCRIPTION CAT 1756-L84E, -L84EK, -L84ES, -L84ESK CUSTOMER DRAWING</p>		<p>Sheet 1 Of 1</p>	
		<p>Drawn by: WBF</p>		<p>Date: 2018-04-10</p>	
				<p>Size D</p>	<p>Ver 01</p>