

MMI PART NUMBER	DESCRIPTION	DIM "A"
200-1991-40	LEG ASSY, PRL PATH, 5 MOT, RU, ML, 745MM SYSTEM HEIGHT	505MM
200-1991-41	LEG ASSY, PRL PATH, 5 MOT, RU, ML, 879MM SYSTEM HEIGHT	639MM
200-1991-42	LEG ASSY, PRL PATH, 5 MOT, RU, ML, 972MM SYSTEM HEIGHT	732MM
200-1991-43	LEG ASSY, PRL PATH, 5 MOT, RU, ML, 838MM SYSTEM HEIGHT	598MM
200-1991-44	LEG ASSY, PRL PATH, 5 MOT, RU, ML, 800MM SYSTEM HEIGHT	560MM
200-1991-45	LEG ASSY, PRL PATH, 5 MOT, RU, ML, 815MM SYSTEM HEIGHT	575MM
200-1991-46	LEG ASSY, PRL PATH, 5 MOT, RU, ML, 889MM SYSTEM HEIGHT	648.5MM

△5  
△6

FIND NUMBER	PART NUMBER	QTY	DESCRIPTION	MATERIAL	VENDOR	VENDOR PART NUMBER
1	100-2136-00	A/R	EXTRUSION, 50MM X 50MM, 14MM SLOT, AL, RU	EN AW-6060-T66	ROBOTUNITS, INC	PIL_5050_NNN
2	100-2102-01	3	FOOT, LEVELING, M10 X 80MM, RU	SEE MFR'S SPEC	ROBOTUNITS, INC	BAS 8010
3	100-2103-00	7	JOINT, TEE, FASTENER, 50MM X 50MM	SEE DWG	ROBOTUNITS, INC	FAS 5051
4	100-2105-03	2	CAP, END, 50MM X 50MM, W/SCREW, BLK ABS, RU	BLK ABS V0 COMPOSITE	ROBOTUNITS, INC	CAP 5051
5	100-0097-30	A/R	LOCTITE 243, THDLKR ANAEROBIC ADH, BLU, .34 OZ BTL	PER MFR'S SPEC	LOCTITE	1329837

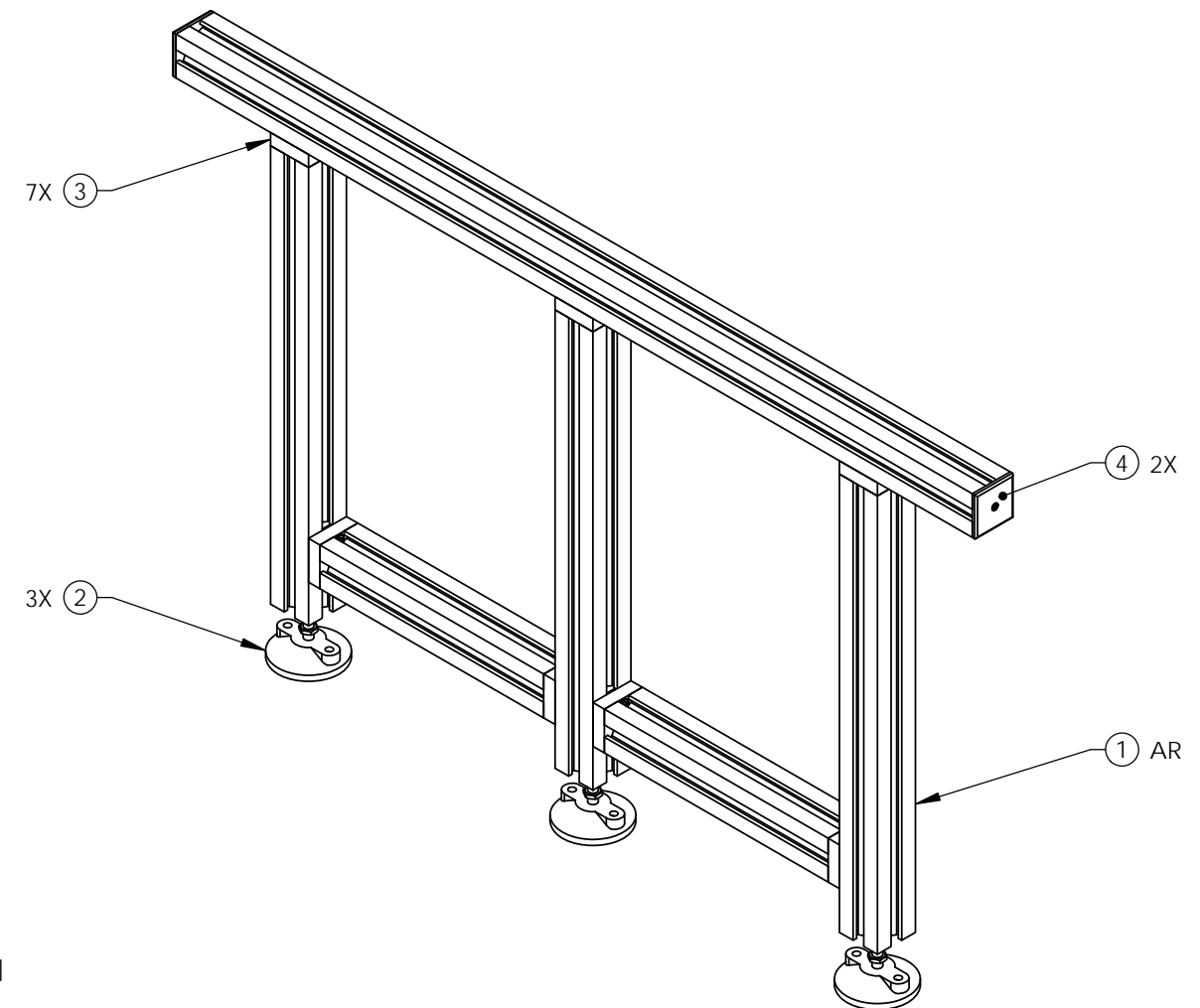
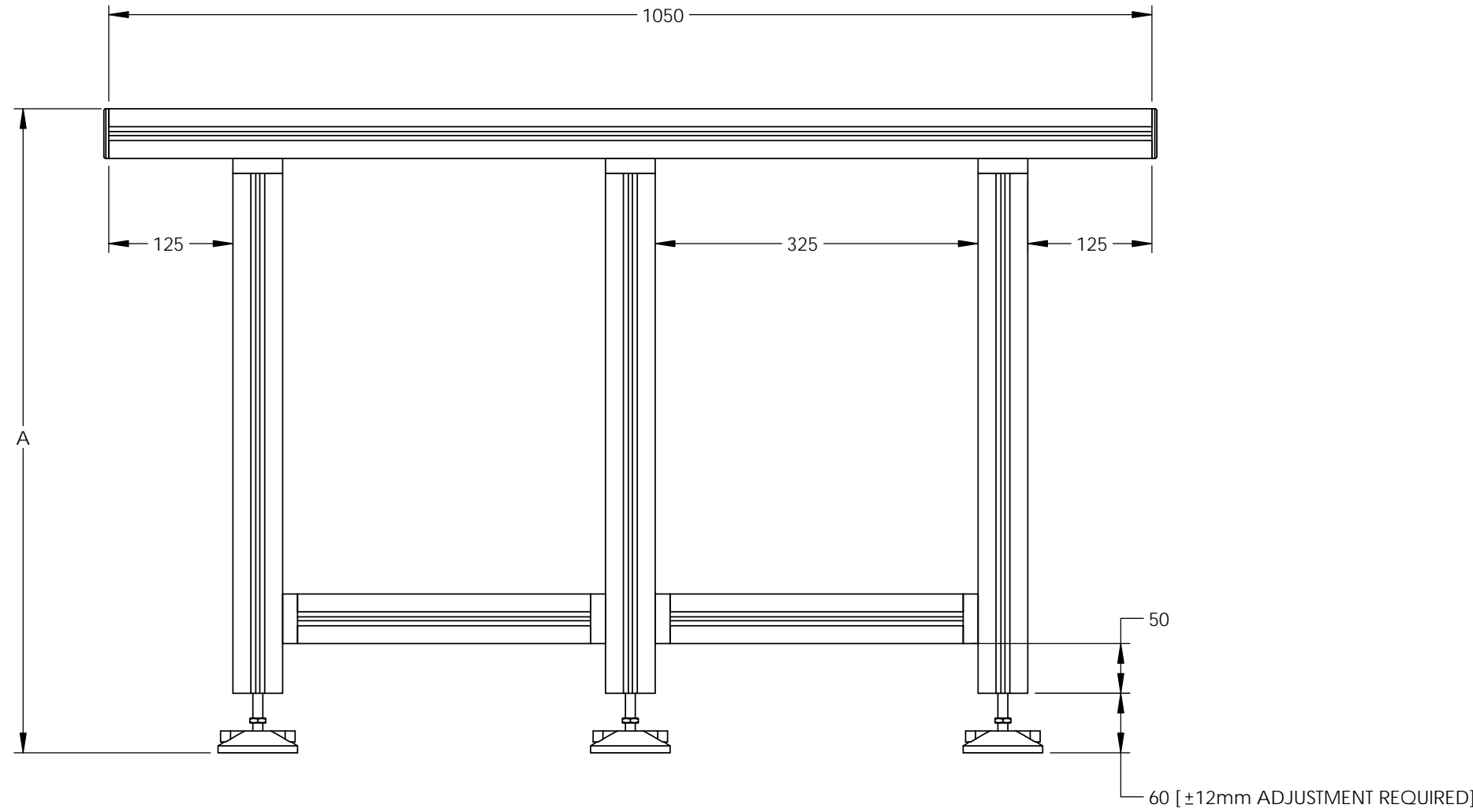

NOTES:

- FINAL ASSEMBLY MUST MEET CLASS 2 SPECIFICATIONS AS DESCRIBED IN MAGNEMOTION SURFACE STANDARD SPECIFICATION (REF#900000715)
- ALL FASTENERS TO HAVE THREAD LOCKER, FIND NUMBER (5) EXCEPT ITEM 3X (2) THREADS
- TORQUE SPECIFICATION:

M8	23Nm (204 IN-LBS)
M10	40Nm (354 IN-LBS)

△6 ADDED -46

△5 ADDED -45

UNLESS OTHERWISE SPECIFIED			<b>MAGNEMOTION CONFIDENTIAL</b> Copyright© 2012 MagneMotion Inc. The information contained in this drawing is the sole property of MagneMotion Inc. Any reproduction in part or whole without the written permission of MagneMotion is prohibited			INTERPRET DRAWING PER ANSI Y14.5M-1982			<b>MagneMotion Inc.</b> 139 Barnum Road Devens, MA 01434 USA (978) 757-9100			TITLE <b>LEG ASSY, PRL PATH, 5 MOT, RU, ML</b>		REV <b>6</b>
ALL DIMENSIONS IN MM	SURFACE FINISH [63] 1.6	TOLERANCES X.XX ± 0.13 X.X ± 0.25 X ± 0.5 DEG ± 0.5° TORQUE ± 25%	DO NOT SCALE DRAWING	SHEET SIZE B	THIRD-ANGLE PROJECTION	PROJECT SB1	DATE 2012-03-01	CAGE CODE <b>1LR11</b>			DWG NO. 200-1991-4X	SHEET 1 OF 1		
BREAK ALL SHARP EDGES			CAD PKG. SolidWorks 2011	SCALE 1:5		ENGINEER M. BOTTASSO	DRAWN BY J. ONEIL							
CLEAN AND DEBURR			CAD FILE 200-1991-4X.SLDDRW											
USE MIN BEND RADII														