



**Allen-Bradley**



**DriveGuard™**

**Safe-Off Option for  
PowerFlex® 700S Phase II  
AC Drives**

**User Manual**

[www.abpowerflex.com](http://www.abpowerflex.com)

**Rockwell  
Automation**

## Important User Information

Solid state equipment has operational characteristics differing from those of electromechanical equipment. *Safety Guidelines for the Application, Installation and Maintenance of Solid State Controls* (Publication SGI-1.1 available from your local Rockwell Automation sales office or online at <http://www.ab.com/manuals/gi>) describes some important differences between solid state equipment and hard-wired electromechanical devices. Because of this difference, and also because of the wide variety of uses for solid state equipment, all persons responsible for applying this equipment must satisfy themselves that each intended application of this equipment is acceptable.

In no event will Rockwell Automation, Inc. be responsible or liable for indirect or consequential damages resulting from the use or application of this equipment.

The examples and diagrams in this manual are included solely for illustrative purposes. Because of the many variables and requirements associated with any particular installation, Rockwell Automation, Inc. cannot assume responsibility or liability for actual use based on the examples and diagrams.

No patent liability is assumed by Rockwell Automation, Inc. with respect to use of information, circuits, equipment, or software described in this manual.

Reproduction of the contents of this manual, in whole or in part, without written permission of Rockwell Automation, Inc. is prohibited.

Throughout this manual, when necessary we use notes to make you aware of safety considerations.



**WARNING:** Identifies information about practices or circumstances that can cause an explosion in a hazardous environment, which may lead to personal injury or death, property damage, or economic loss.

---

**Important:** Identifies information that is critical for successful application and understanding of the product.

---



**ATTENTION:** Identifies information about practices or circumstances that can lead to personal injury or death, property damage, or economic loss. Attentions help you:

- identify a hazard
  - avoid the hazard
  - recognize the consequences
- 



**Shock Hazard** labels may be located on or inside the equipment (e.g., drive or motor) to alert people that dangerous voltage may be present.

---



**Burn Hazard** labels may be located on or inside the equipment (e.g., drive or motor) to alert people that surfaces may be at dangerous temperatures.

---

PowerFlex is a registered trademark of Rockwell Automation, Inc.

DriveExplorer, DriveExecutive, and SCANport are trademarks of Rockwell Automation, Inc.

PLC is a registered trademark of Rockwell Automation, Inc.

# Table of Contents

<b>Section</b>	<b>Page</b>
<a href="#">General Description</a>	<a href="#">2</a>
<a href="#">What Is the PowerFlex Safe-Off Option?</a>	<a href="#">2</a>
<a href="#">Safety of Machinery Standards</a>	<a href="#">3</a>
<a href="#">CE Conformity</a>	<a href="#">3</a>
<a href="#">Approved Equipment</a>	<a href="#">3</a>
<a href="#">Installation and Wiring</a>	<a href="#">4</a>
<a href="#">Option Board Installation</a>	<a href="#">5</a>
<a href="#">Wiring</a>	<a href="#">11</a>
<a href="#">Configure Hardware Enable</a>	<a href="#">12</a>
<a href="#">Configure Digital Outputs</a>	<a href="#">13</a>
<a href="#">Linking Parameters</a>	<a href="#">13</a>
<a href="#">Verify Operation</a>	<a href="#">14</a>
<a href="#">Description of Operation</a>	<a href="#">15</a>
<a href="#">Supplemental Information</a>	<a href="#">18</a>
<a href="#">Certification</a>	<a href="#">18</a>

## General Description

When used with suitable safety components, the PowerFlex 700S Safe-Off with Second Encoder option provides protection according to EN 954-1:1997; Category 3 for safe-off and protection against restart. The PowerFlex Safe-Off option is just one safety control system. All components in the system must be chosen and applied correctly, to achieve the desired level of operator safeguarding.

### What Is the PowerFlex Safe-Off Option?

The PowerFlex Safe-Off option:

- Is designed to safely remove power from the gate firing circuits of the Drive's output power devices (IGBT's). This prevents them from switching in the sequence necessary to generate torque in the motor.
- Can be used in combination with other safety devices to provide Category 0 (Coast) stop according to EN 60204-1 and NFPA 79.
- The Safe-Off option in the PowerFlex 700S provides Category 3 performance according to EN 954-1.

**Important:** The option is suitable for performing mechanical work on the drive system or affected area of a machine only. It does not provide electrical safety.



**ATTENTION:** To avoid an electric shock hazard, verify that the voltage on the bus capacitors has discharged before performing any work on the drive. Measure the DC bus voltage at the +DC and -DC terminals or test points (refer to your drive's *User Manual* for locations). The voltage must be zero.



**ATTENTION:** In safe-off mode, hazardous voltages may still be present at the motor. To avoid an electric shock hazard, disconnect power to the motor and verify that the voltage is zero before performing any work on the motor.

---

## Safety of Machinery Standards

The Safe-Off with Second Encoder option meets the following safety standards:

- EN 60204-1 Safety of machinery – Electrical equipment of machines – Part 1: General Requirements
- EN 954-1:1997; Category 3 - Safety-related parts of control systems

## CE Conformity

Conformity with the Low Voltage (LV) Directive and Electromagnetic Compatibility (EMC) Directive has been demonstrated using harmonized European Norm (EN) standards published in the Official Journal of the European Communities. PowerFlex Drives comply with the EN standards listed below when installed according to the User and Reference Manuals.

CE Declarations of Conformity are available online at:  
<http://www.ab.com/certification/ce/docs>.

### Low Voltage Directive (73/23/EEC)

- EN50178 Electronic equipment for use in power installations

### EMC Directive (89/336/EEC)

- EN61800-3 Adjustable speed electrical power drive systems Part 3: EMC product standard including specific test methods.

## Approved Equipment

The following PowerFlex 700S Phase II AC Drives are certified to EN 954-1, Category 3:

- 208/240V Frames 1-6
- 400/480V Frames 1-6
- 600/690V Frames 5 & 6

The safety function for the following PowerFlex 700S Phase II AC Drives are approved to EN 954-1, Category 3:

- 600V Frames 1-4

## Installation and Wiring

Installation must be in accordance with the following steps and must be carried out by suitably competent personnel. This device is intended to be part of the safety related control system of a machine. Before installation, a risk assessment should be performed to determine whether the specifications of this device are suitable for all foreseeable operational and environmental characteristics of the machine to which it is to be fitted.

At regular intervals during the life of the machine check the safety function for proper operation. How frequently the safety function is checked is dependent on the safety analysis of the machine section controlled by the drive.

Rockwell Automation, Inc. cannot accept responsibility for a failure of this device if the procedures given in this publication are not implemented or if it is used outside the recommended specifications in this publication.



**ATTENTION:** The following information is merely a guide for proper installation. Rockwell Automation, Inc. cannot assume responsibility for the compliance or the noncompliance to any code, national, local or otherwise for the proper installation of this equipment. A hazard of personal injury and/or equipment damage exists if codes are ignored during installation.

---

## Option Board Installation

1. Remove the I/O Control Cassette from the drive.

Task	Description
<b>A</b>	Open the door of the power structure and disconnect the cables that connect to the main board
<b>B</b>	Loosen screws on face of cassette
<b>C</b>	Remove the cassette

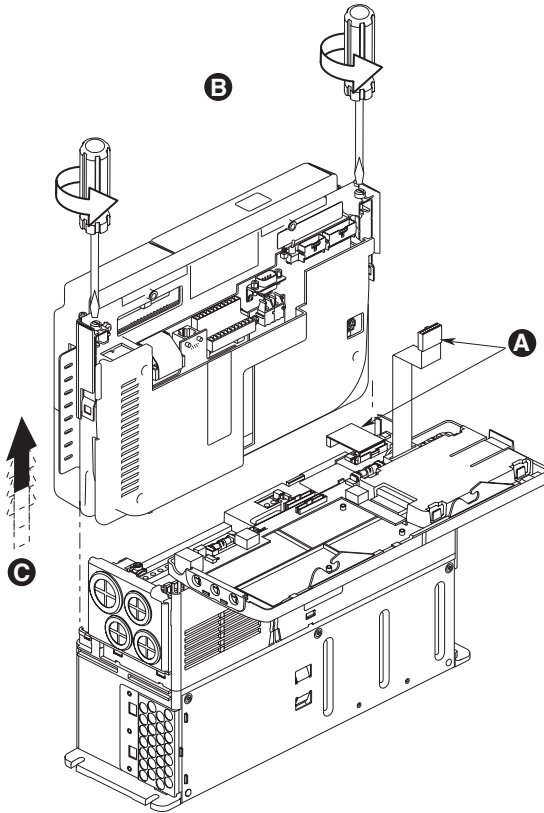

2. Remove the screws securing the interior cassette cover to gain access to the Main board.

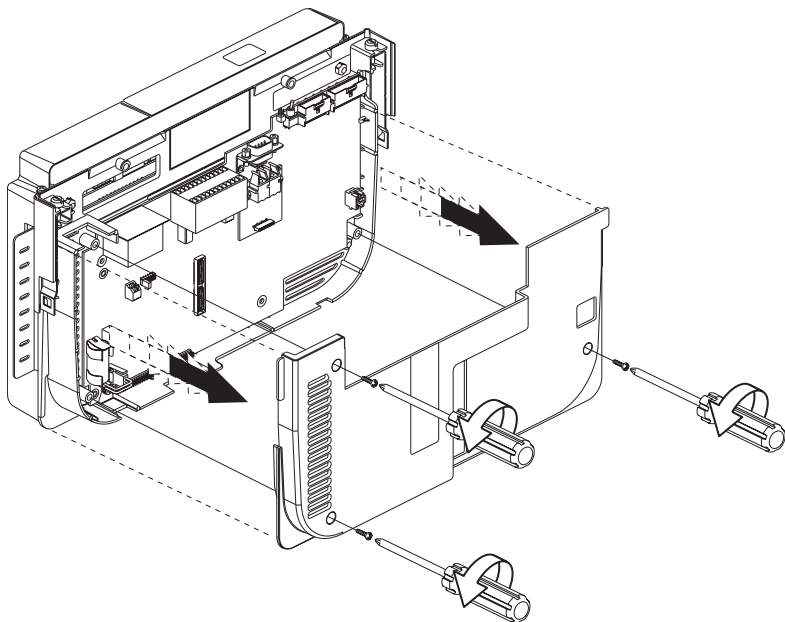

3. Remove the 2-pin shunt jumper from the 16-15 pin position.

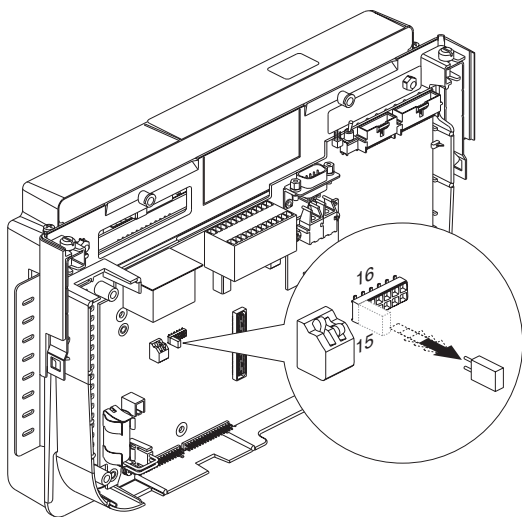

**Important:** If the Safe-Off option is removed from the drive, this jumper must be reinstalled or the drive will not run.



4. Remove the exterior cassette covers to access the grounding plate.

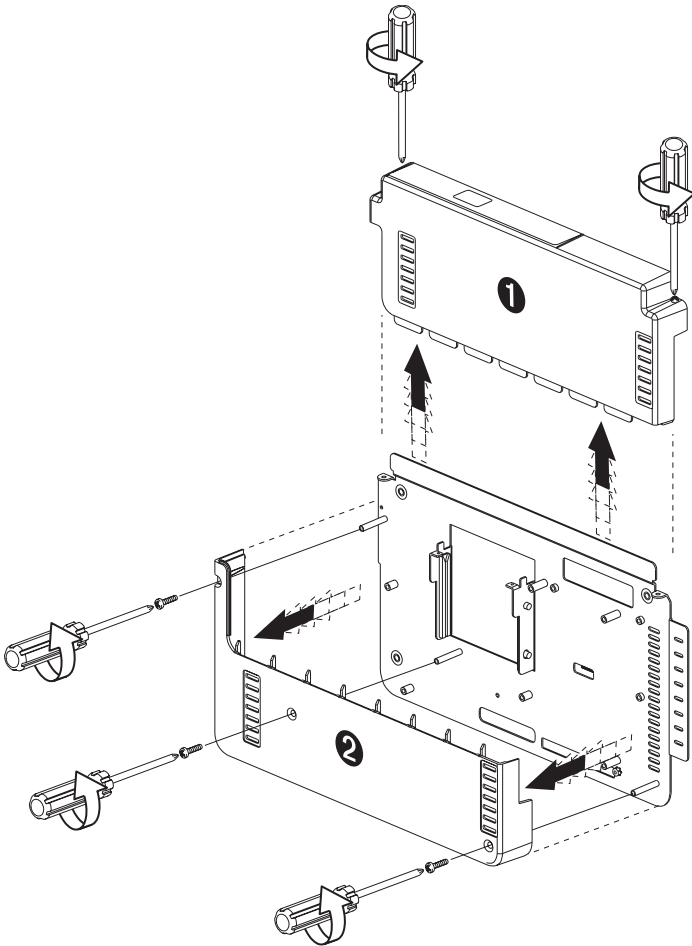

5. Install the 16-pin stacker connector.

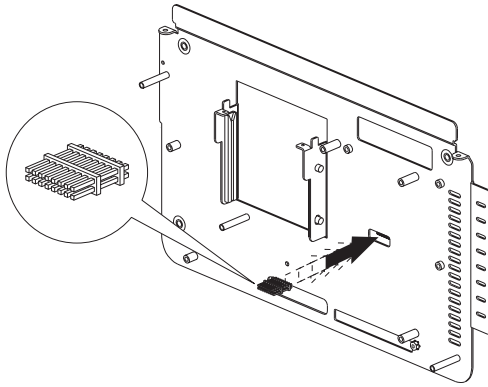

6. Plug the Safe-Off with Second Encoder into the 16-pin connector.

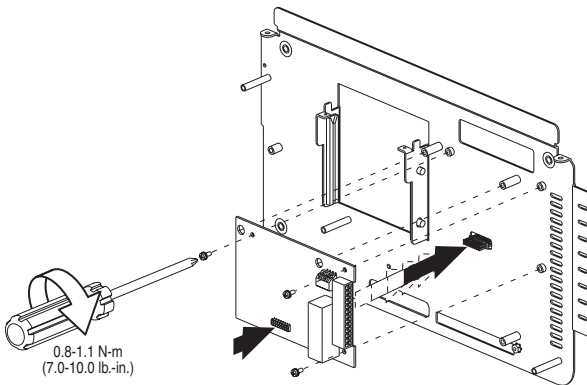

7. Install and tighten mounting screws.

8. Install the exterior cassette covers.

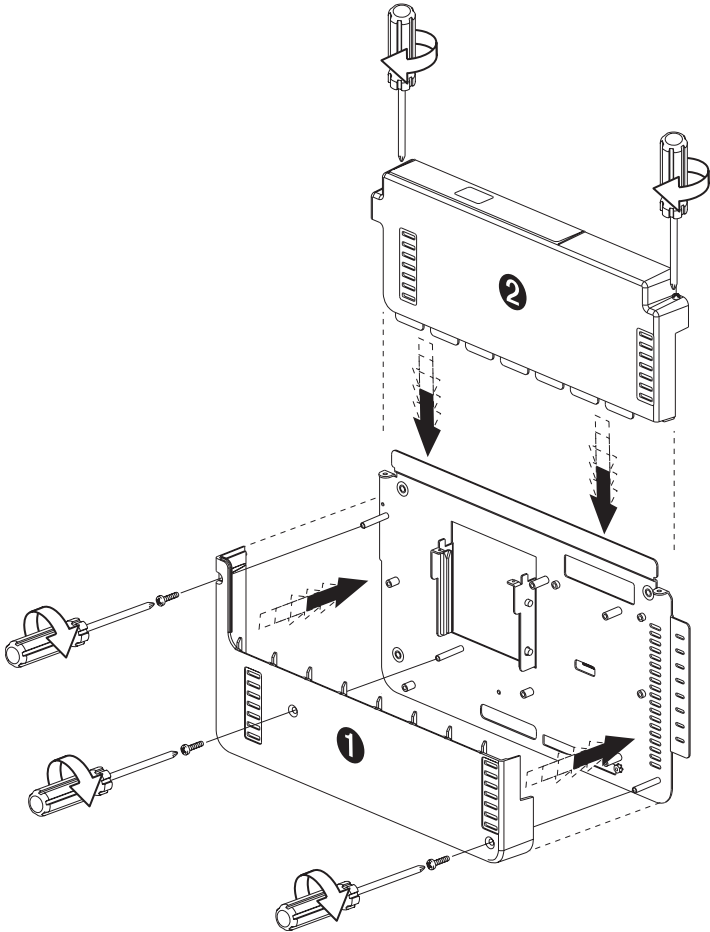

**9. Install the inside front cover.**

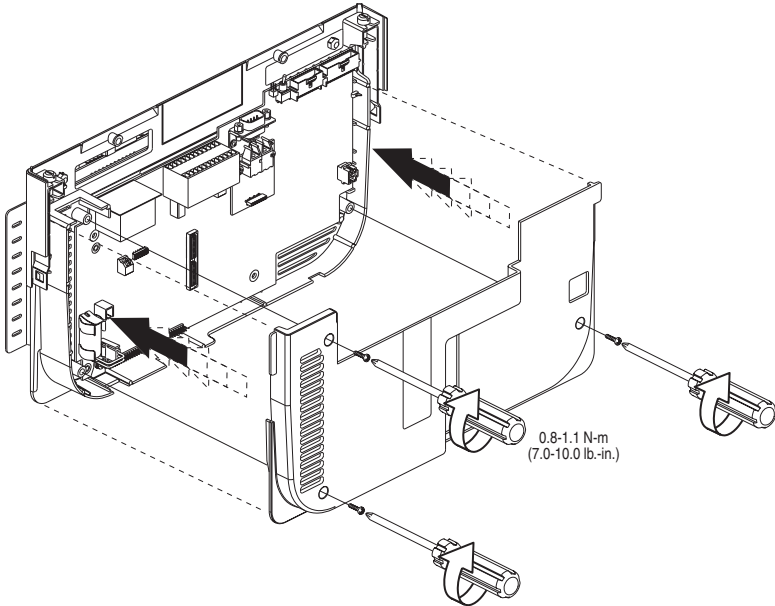

**10. Reinstall the cassette in the drive.**

**11. Record the modification on the Field Installed Option label.**

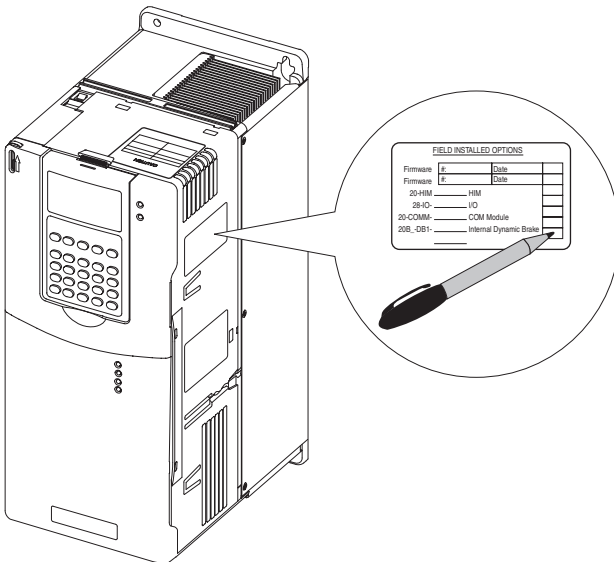

## Wiring

Important points to remember about wiring:

- Always use copper wire.
- Wire with an insulation rating of 600V or greater is recommended.
- Control wires should be separated from power wires by at least 0.3 meters (1 foot).

### Safe-Off with Second Encoder Terminal Block Specifications

Wire Size Range <sup>(1)</sup>		Torque	
Maximum	Minimum	Maximum	Recommended
1.5 mm <sup>2</sup> (16 AWG)	0.14 mm <sup>2</sup> (26 AWG)	0.25 N-m (2.2 lb.-in.)	0.22 N-m (1.9 lb.-in.)

<sup>(1)</sup> Maximum / minimum that the terminal block will accept - these are not recommendations.

### Wire Types

	Wire Type(s)	Description	Minimum Insulation Rating
Unshielded	Per US NEC or applicable national or local code	—	300V, 60 degrees C (140 degrees F)
Shielded	Multi-conductor shielded cable such as Belden 8770 (or equiv.)	0.750 mm <sup>2</sup> (18AWG), 3 conductor, shielded.	

### Safe-Off Terminals Description

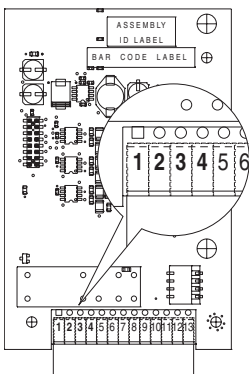

No.	Signal	Description
1	+24V DC	Connections for user supplied power to energize coil.
2	24V Common	33.3 mA typical, 55 mA maximum.
3	Monitor - N.C.	Normally closed contacts for monitoring relay status.
4	Common - N.C.	Maximum Resistive Load: 250V AC / 30V DC / 50 VA / 60 Watts Maximum Inductive Load: 250V AC / 30V DC / 25 VA / 30 Watts

## Configure Hardware Enable

Ensure that Jumper P22 on the Main Control Board is set to HW Enable (Pins 2 and 4).

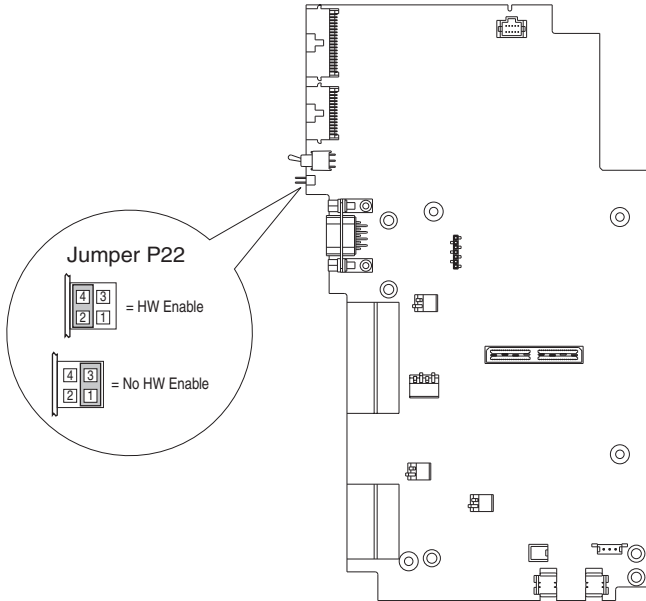

**Important:** In addition to the correct jumper setting, Enable circuitry must be connected to I/O Terminals 13 and 16. Refer to the PowerFlex 700S Phase II Control *User Manual*, publication 20D-UM006, for wiring examples.

## Configure Digital Outputs

Digital Output 1 and 2 (TB2 Terminals 3, 4 and 5) and Relay Output 3 (TB2 Terminals 6, 7 and 8) can be configured to activate external logic in the event the safety enable diagnostic routine results in an F45 “Enable Health” fault.

1. Set Par 147 [FW Functions En], Bit 14 “Digital Outs” to 1 (True).
2. Set Par 845 [Dig Out1 Sel], 850 [Dig Out2 Sel] or 855 [Rly Out3 Sel] to option 0 “User Select”.
3. Link Par 846 [Dig Out1 Data], 851 [Dig Out2 Data] or 856 [Rly Out3 Data] to Par 324 [Fault Status 2]. See “Linking Parameters” below.
4. Set Par 847 [Dig Out1 Bit], 852 [Dig Out2 Bit] or 857 [Rly Out3 Bit] to 12. Par 324 Bit 12 = EnableHealth status.

## Linking Parameters

Use the following procedure to establish a link between Par 846 [Dig Out1 Data], 851 [Dig Out2 Data] or 856 [Rly Out3 Data] and Par 324 [Fault Status 2].

1. Using the drive’s Human Interface Module (HIM) select Parameter from the Main Menu and press the Enter key.
2. Using the HIM keypad, enter 846, 850, or 856 and press the Enter key. The parameter value screen will appear.
3. Press ALT and then View (Sel). Next, press the Up or Down Arrow to change “Present Value” to “Defined Link.” Press the Enter key.
4. Press the Enter key to select the “Link” field. Using the HIM keypad, enter 324 as the Source Parameter Number and press the Enter key.

The linked parameter can now be viewed two different ways by repeating the steps above and selecting “Preset Value” or “Define Link.” If an attempt is made to edit the value of a linked parameter, “Parameter is Linked!” will be displayed, indicating that the value is coming from a source parameter and can not be edited.

5. To remove a link, repeat the steps above and change the source parameter to zero (0).

## Verify Operation

At regular intervals during the life of the machine check the safety function for proper operation. Both safety channels shall be verified using the table below. How frequently the safety function is checked is dependent on the safety analysis of the machine section controlled by the drive.

Safety Function Status	Drive In Safe State	Drive In Safe State	Drive In Safe State	Drive Able To Run
<b>Safety Channel Operation</b>				
<b>Safe-Off Option</b> Terminals 1 & 2	No Power Applied	Power Applied	No Power Applied	Power Applied
<b>PowerFlex 700S</b> Enable Input	No Power Applied	No Power Applied	Power Applied	Power Applied
<b>Description For Verification</b>				
<b>Safe-Off Option</b> Monitor Contact Terminals 3 & 4	Closed	Open	Closed	Open
<b>PowerFlex 700S</b> Drive Inhibits Param. 156, Bits 1 & 16	Bit 16 = 0 Bit 1 = 1	Bit 16 = 0 Bit 1 = 1	Bit 16 = 1 Bit 1 = 0	Bit 16 = 0 Bit 1 = 0



# Description of Operation

The PowerFlex 700S Safe-Off option (see [Figure 1](#)) disables the drive's output IGBT's by disconnecting the gate control power supply. When used in combination with a second safety channel (the Enable input), the system satisfies the requirements of EN 954-1, Category 3 for safe-off and protection against restart.

Under normal drive operation, the Safe-Off relay is energized, the enable input is energized, and gate control power is available to the gate control circuit. If either of these inputs is de-energized, the gate control circuit is disabled. To meet EN 954-1, Category 3 operation, both safety channel inputs to the drive must be controlled (de-energized) to safely turn off output to the motor. Refer to the following examples for details.

**Important:** By itself, the Safe-Off option initiates a coast-to-stop action. If coasting to a stop is not desired, additional protective measures should be taken.

**Figure 1** Safe-Off Drive Circuitry

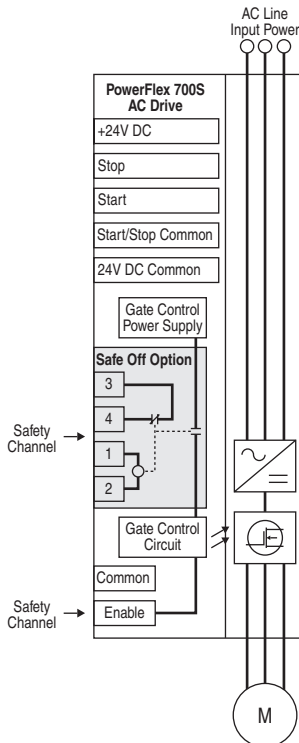

## Example 1 Safe-Off Connection with Coast-to-Stop Action, Dual Channel

Figure 2 Stop Category 0 – Coast

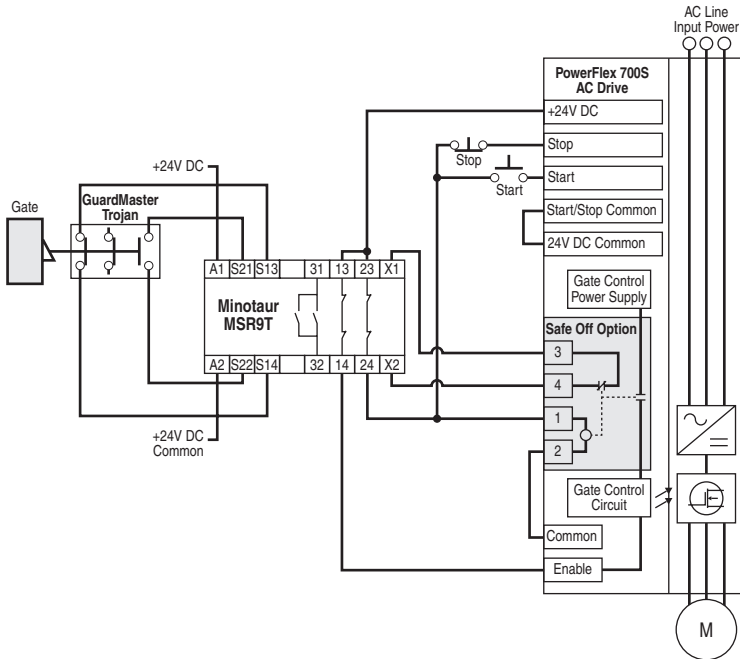

**Circuit Status** – Circuit shown with guard door closed and system ready for normal drive operation.

**Operating Principle** – This is a dual channel system with monitoring of the safe-off circuit and drive. Opening the guard door will switch the input circuits (S13-S14 & S21-S22) to the Minotaur monitoring safety relay unit. The output circuits (13-14 & 23-24) will cause the Safe-Off option and drive Enable circuit to go immediately to a safe state (off) and the motor will coast to stop. To restart the drive, the Minotaur safety relay inputs (S13-S14, S21-S22) must first be ready for normal drive operation followed by a valid start command to the drive.

**Fault Detection** – A single fault detected on the Minotaur safety input circuits will result in the lock-out of the system to a safe state (off) at the next operation and will not cause loss of the safety function.

If the Safe-Off option sticks ON, the motor will stop on command due to the enable input. The system cannot be reset and thereby reveals the fault condition to the operator.

**Application Considerations** – When the hazard analysis for the overall machine determines the need for external mechanical brakes or other stopping means, the external means shall be activated after the removal of power for Stop Category 0.

## Example 2 Safe-Off Connection with Controlled Stop Action, Dual Channel

Figure 3 Stop Category 1 – Controlled

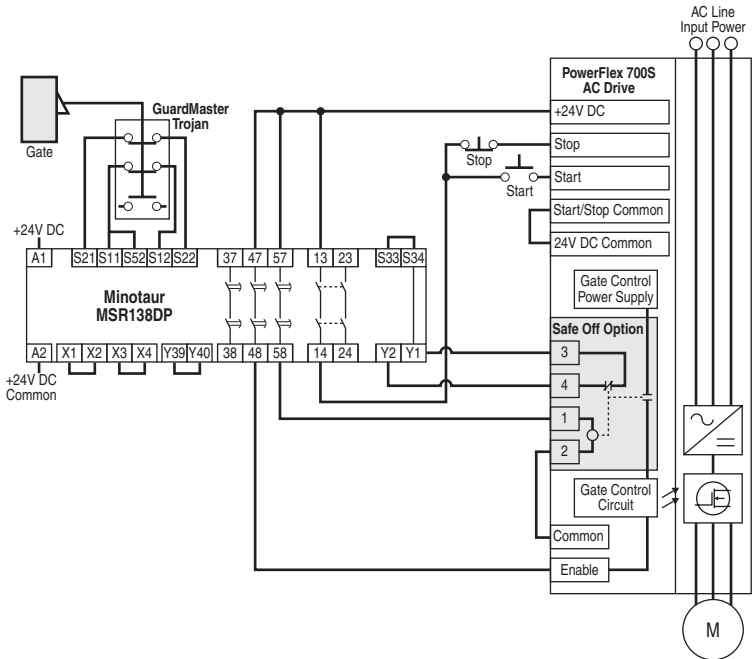

**Circuit Status** – Circuit shown with guard door closed and system ready for normal operation.

**Operating Principle** – This is a dual channel system with monitoring of the safe-off circuit and drive. Opening the guard door will switch the input circuits (S11-S12 & S21-S22) to the Minotaur monitoring safety relay unit. The immediate output circuits (13-14) will issue a Stop command to the drive and cause a controlled deceleration. After the programmed delay, the timed output circuits (47-48 & 57-58) will cause the Safe-Off option and the drive Enable circuit to go to a safe state (off). If the motor has not stopped rotating, it will coast to stop. To restart the drive, the Minotaur safety relay inputs (S11-S12, S21-S22) must first be ready for normal drive operation followed by a valid start command to the drive.

**Fault Detection** – A single fault detected on the Minotaur safety input circuits will result in the lock-out of the system to a safe state (off) at the next operation and will not cause loss of the safety function.

If the Safe-Off option sticks ON, the motor will stop on command due to the enable input. The system cannot be reset and thereby reveals the fault condition to the operator.

# Supplemental Information

## Certification



**TÜV Rheinland Group**

**TÜV Industrie Service GmbH**  
Automation, Software und Informationstechnologie

### ZERTIFIKAT CERTIFICATE

Nr./No. 968/EZ 189.00/05

<b>Prüfgegenstand/ Product tested</b>	Adjustable Frequency AC Drive	<b>Zertifikatsinhaber/ License holder Hersteller/ Manufacturer</b>	Rockwell Automation 6400 West Enterprise Drive USA-Mequn, WI 53092 United States of America
<b>Typbezeichnung/ Type designation</b>	Allen Bradley PowerFlex 700S AC Drive Frame 1/2/3/4/5/6 240 V, 400 V, 480 V and corresponding DC input voltage ratings Frame 5/6 600 V, 690 V and corresponding DC input voltage ratings	<b>Verwendungszweck/ Intended application</b>	Safety relevant applications; Safety Function "Safe standstill" according to EN 954-1 3
<b>Prüfgrundlagen/ Codes and standards forming the basis of testing</b>	EN 954-1:1996 EN ISO 13849-2:2003 EN 60204-1:1997 EN 50178:1997 EN 61800-3:1996 & A11:2000		
<b>Prüfungsergebnis/ Test results</b>	The safety function "Safe standstill" meets the requirements for category 3 according to EN 954-1.		
<b>Besondere Bedingungen/ Specific requirements</b>	Fault exclusion for the external wiring has to be made according to EN ISO 13849-2.  The user manual "Safe Off Option for PowerFlex 700S AC Drive" has to be considered.		



Der Prüfbericht-Nr. 968/EZ 189.00/05 vom 2005-02-25 ist Bestandteil dieses Zertifikates.

Der Inhaber eines für den Prüfgegenstand gültigen Genehmigungs-Ausweises ist berechtigt, die mit dem Prüfgegenstand übereinstimmenden Erzeugnisse mit dem abgebildeten Prüfzeichen zu versehen.

The test report-no. 968/EZ 189.00/05 dated 2005-02-25 is an integral part of this certificate.

The holder of a valid licence certificate for the product tested is authorized to affix the test mark shown opposite to products, which are identical with the product tested.

**TÜV Industrie Service GmbH**  
Geschäftsfeld ASI  
Automation, Software und Informationstechnologie  
Am Grauen Stein, 51105 Köln  
Postfach 91 09 St, 51101 Köln

*H. Gall*

2005-02-25

Datum/Date

Firmenstempel/Company seal

Unterschrift/Signature





[www.rockwellautomation.com](http://www.rockwellautomation.com)

**Corporate Headquarters**

Rockwell Automation, 777 East Wisconsin Avenue, Suite 1400, Milwaukee, WI, 53202-5302 USA, Tel: (1) 414.212.5200, Fax: (1) 414.212.5201

**Headquarters for Allen-Bradley Products, Rockwell Software Products and Global Manufacturing Solutions**

Americas: Rockwell Automation, 1201 South Second Street, Milwaukee, WI 53204-2496 USA, Tel: (1) 414.382.2000, Fax: (1) 414.382.4444  
Europe/Middle East/Africa: Rockwell Automation SA/NV, Vorstlaan/Boulevard du Souverain 36, 1170 Brussels, Belgium, Tel: (32) 2 663 0600, Fax: (32) 2 663 0640  
Asia Pacific: Rockwell Automation, 27/F Citicorp Centre, 18 Whitfield Road, Causeway Bay, Hong Kong, Tel: (852) 2687 4766, Fax: (852) 2506 1846

**Headquarters for Dodge and Reliance Electric Products**

Americas: Rockwell Automation, 6040 Ponders Court, Greenville, SC 29615-4617 USA, Tel: (1) 864.297.4800, Fax: (1) 864.281.2433  
Europe/Middle East/Africa: Rockwell Automation, Brühlstraße 22, D-74834 Elztal-Dallau, Germany, Tel: (49) 6261 9410, Fax: (49) 6261 17741  
Asia Pacific: Rockwell Automation, 55 Newton Road, #11-01/02 Revenue House, Singapore 307987, Tel: (65) 6356-9077, Fax: (65) 6356-9011

**U.S. Allen-Bradley Drives Technical Support**

Tel: (1) 262.512.8176, Fax: (1) 262.512.2222, Email: [support@drives.ra.rockwell.com](mailto:support@drives.ra.rockwell.com), Online: [www.ab.com/support/abdrives](http://www.ab.com/support/abdrives)