

CRITICAL TO QUALITY CLASSIFICATION TABLE				
P=PERFORMANCE, F=FIT, A=ASSEMBLY				
X=IDENTIFIES APPLICABLE CLASSIFICATION(S)				
◇=ENGINEERING AND/OR MANUFACTURING REQUIREMENT				
⊙=REGULATORY REQUIREMENT-CONFORMANCE IS MANDATORY				
COMMENTS	DRAWING ZONE	◇	◇	◇
ROHS	G1-H1			X

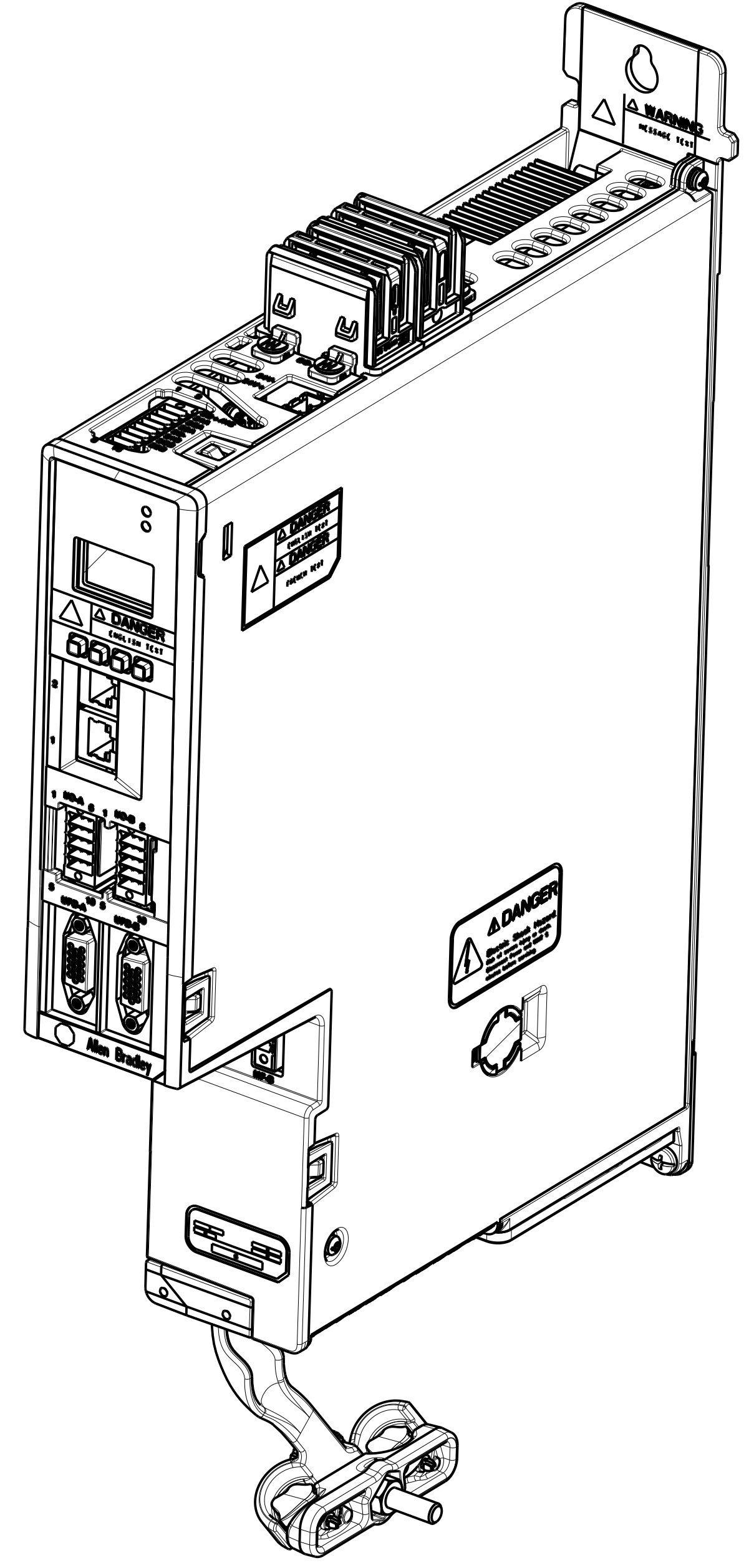

SCALE 0.750

NOTE:
1. DIMENSIONS ARE IN MILLIMETERS

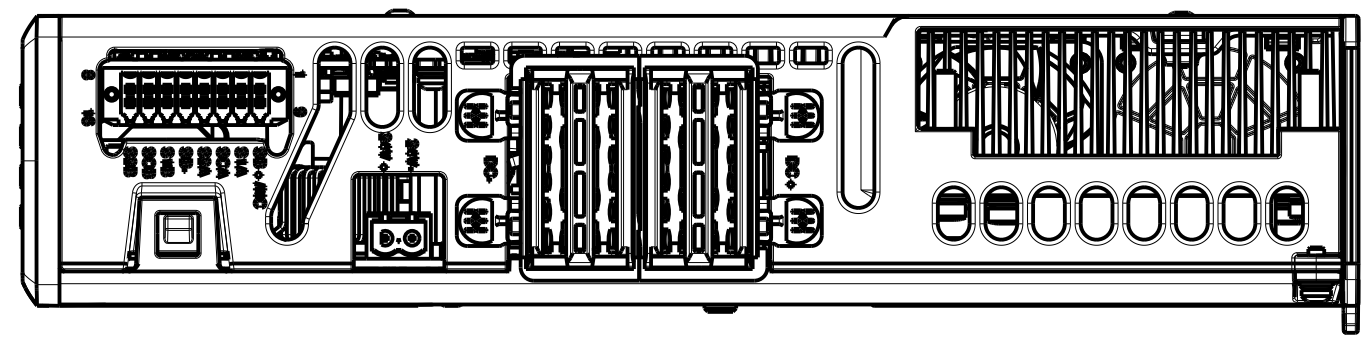
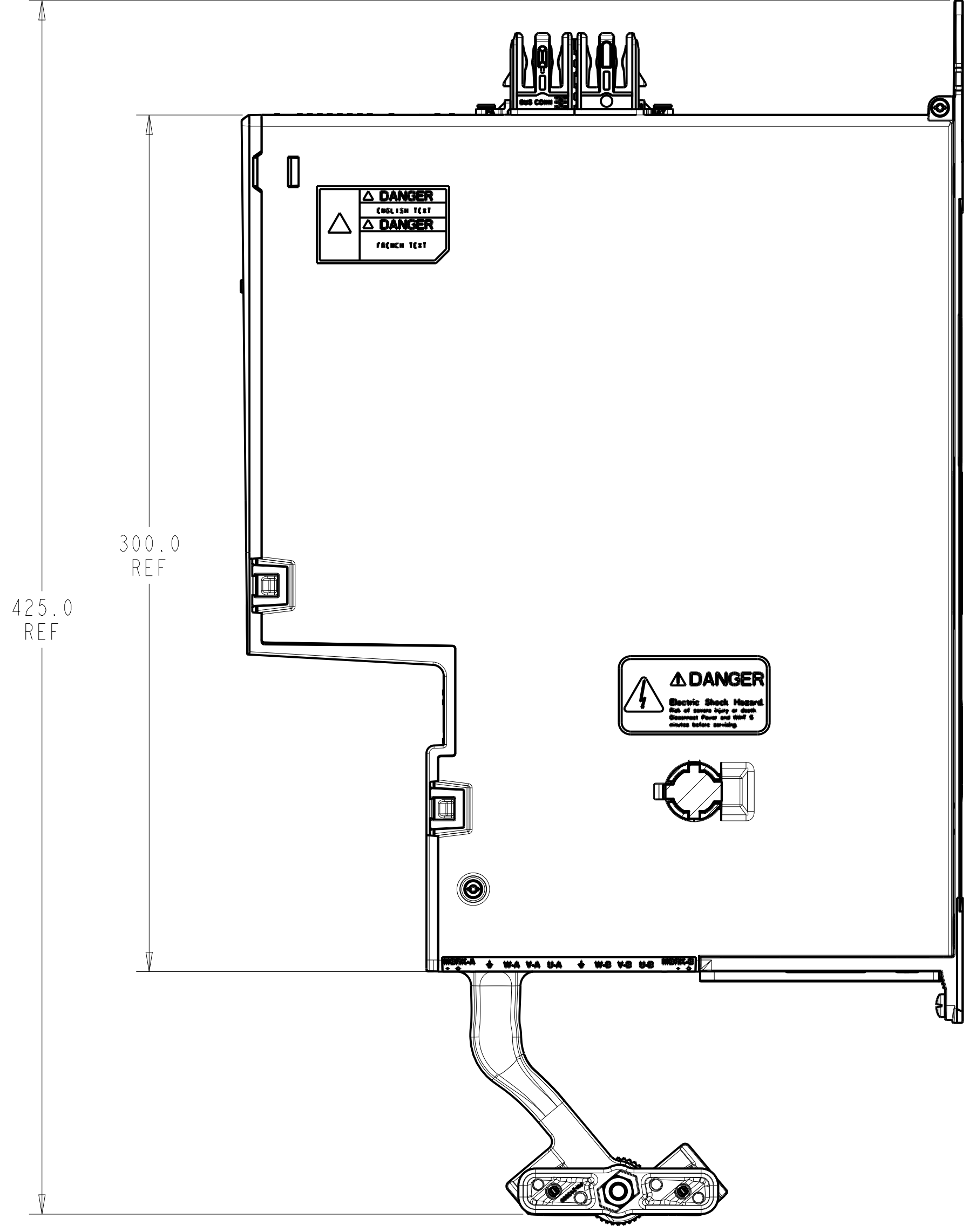
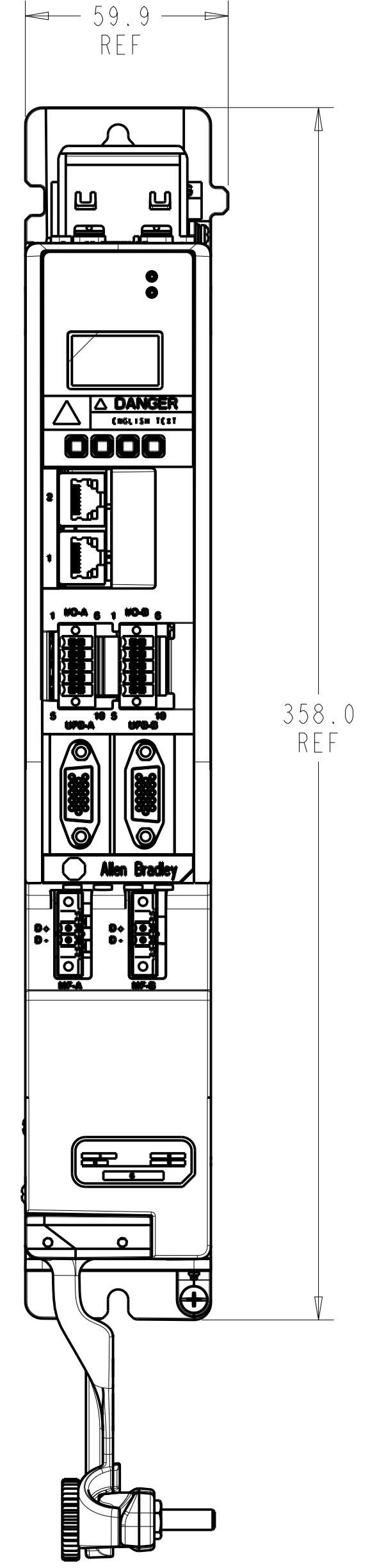
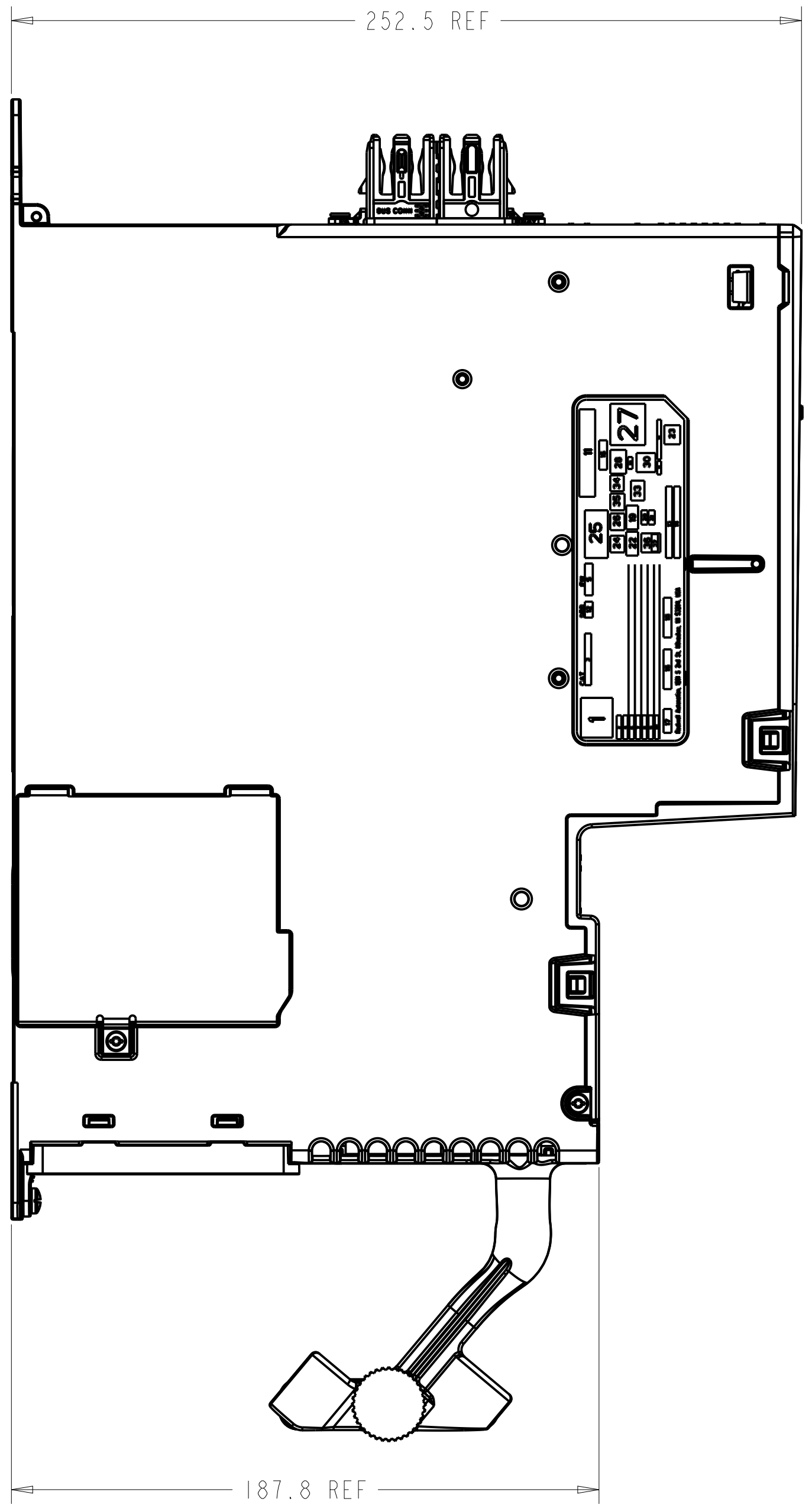
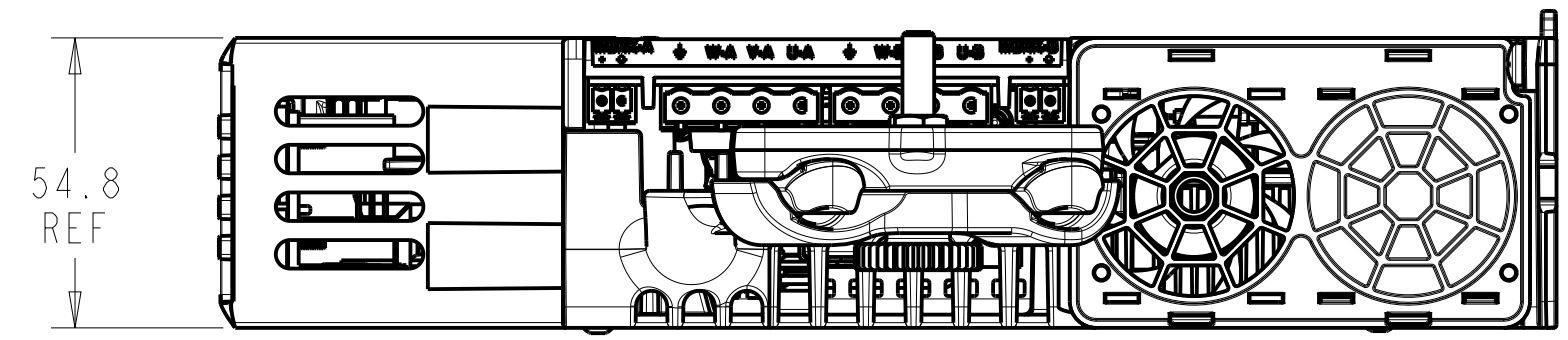

MUST COMPLY WITH ROCKWELL AUTOMATION ENVIRONMENTAL SPECIFICATION 970-20-01

DIMENSION UNITS - mm		ALL UNDIMENSIONED GEOMETRIES ARE CONTROLLED BY THE CAD MODEL. IN CASE OF DIMENSION DISCREPANCY, CAD MODEL OVERRIDES.
DIMENSIONS APPLY BEFORE SURFACE TREATMENT. UNSPECIFIED TOLERANCES ARE AS FOLLOWS:		
.X:±	N/A	
.XX:±	N/A	
ANG:±	N/A	THIRD ANGLE PROJECTION



OUTLINE DRAING 2198-DOXX-ERSX

CREATED BY:NMWIEBER CHANGED BY:PTHAKRE

CONFIDENTIAL AND PROPRIETARY INFORMATION. THIS DOCUMENT CONTAINS CONFIDENTIAL AND PROPRIETARY INFORMATION OF ROCKWELL AUTOMATION, INC. AND MAY NOT BE USED, COPIED OR DISCLOSED TO OTHERS, EXCEPT WITH THE AUTHORIZED WRITTEN PERMISSION OF ROCKWELL AUTOMATION, INC.

DATE:2020-03-13	SHEET 1 OF 1
SIZE D1R	VER
10006361696	00