

442L-AMBSZCP1 : SAFEZONE CIP SAFETY LASER SCANNER MOUNTING BRACKET 1

CRITICAL TO QUALITY CLASSIFICATION TABLE				
P=PERFORMANCE, F=FIT, A=ASSEMBLY				
X=IDENTIFIES APPLICABLE CLASSIFICATION(S)				
⊠=ENGINEERING AND/OR MANUFACTURING REQUIREMENT				
Ⓜ=REGULATORY REQUIREMENT - CONFORMANCE IS MANDATORY				
COMMENTS	DRAWING (ZONE)	P	F	A
ROHS	H1			X

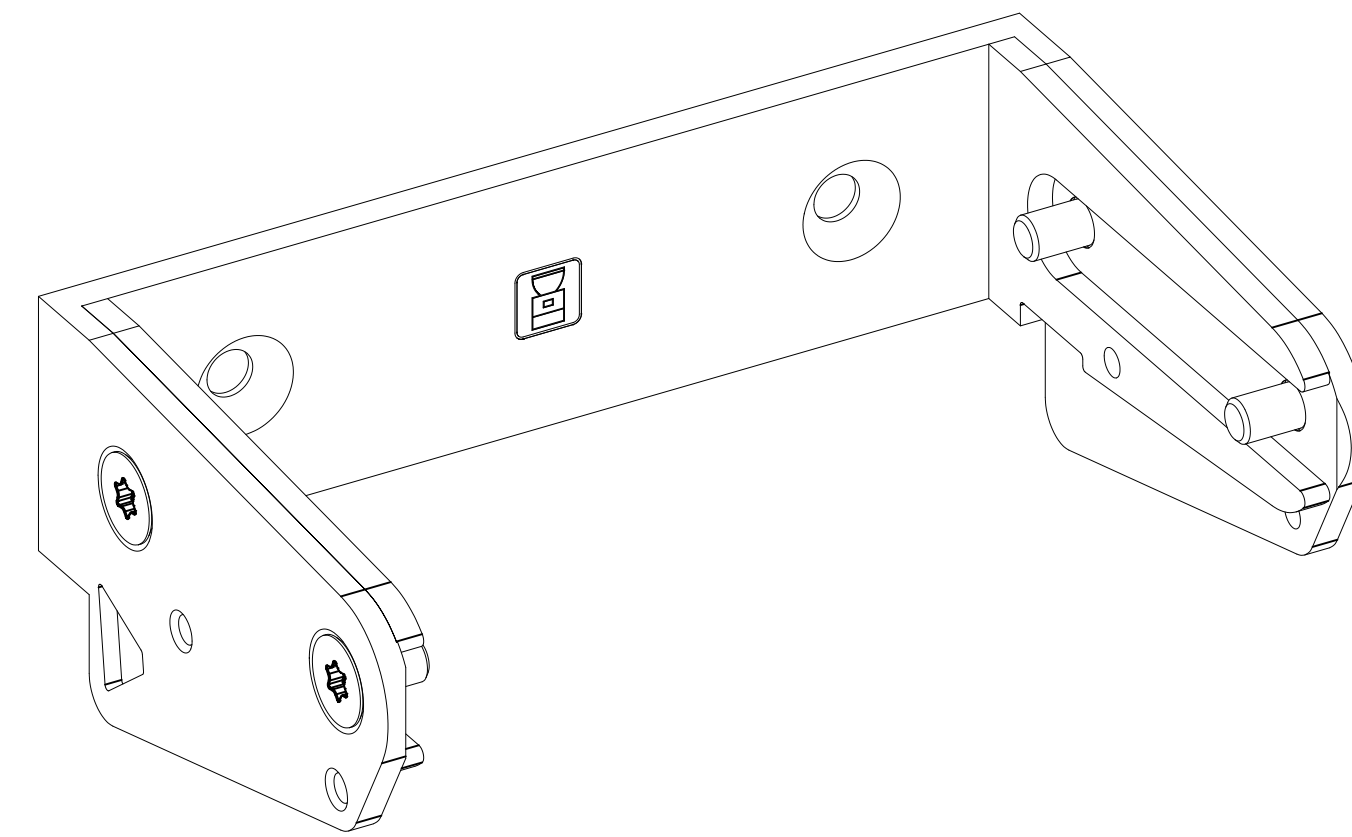
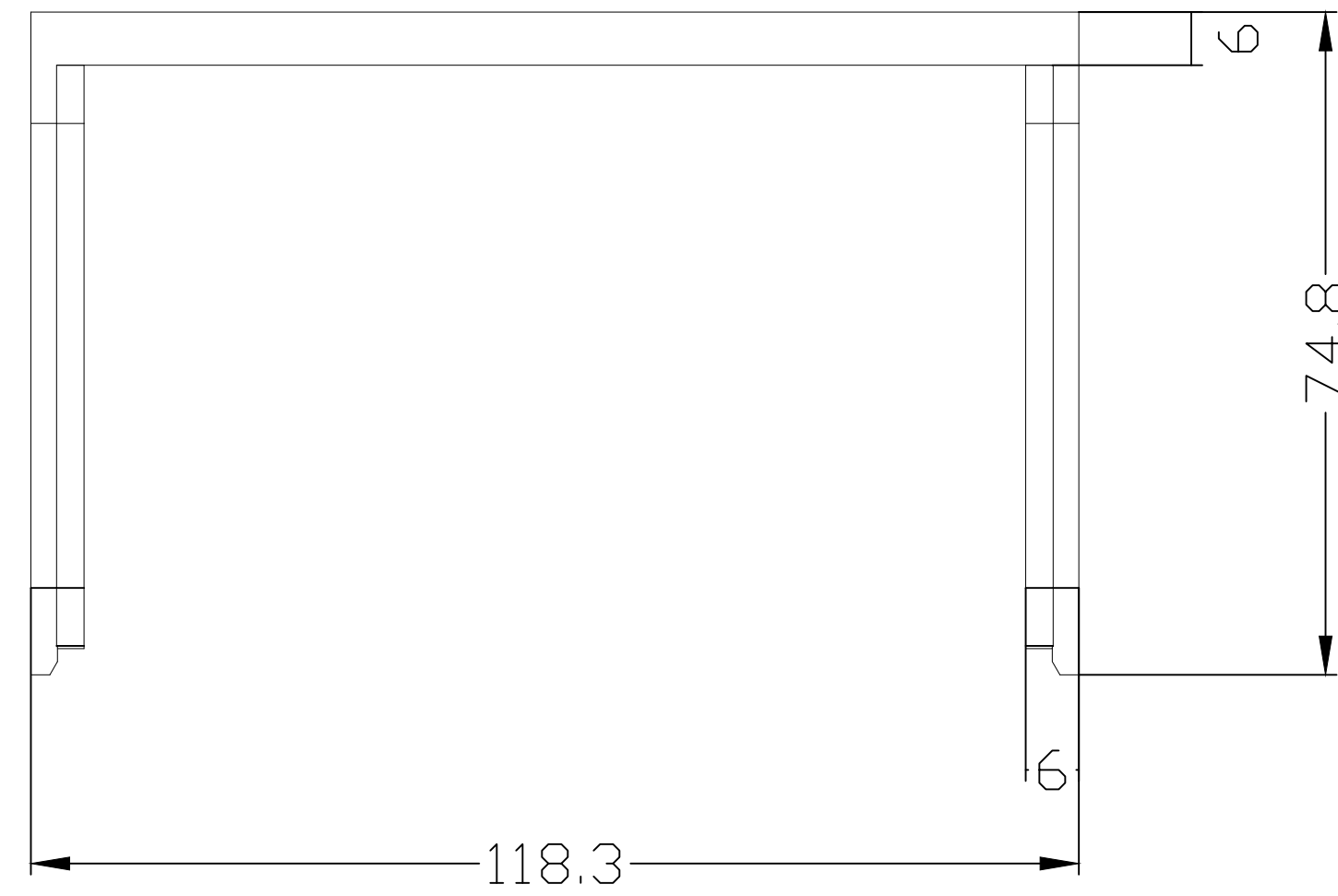
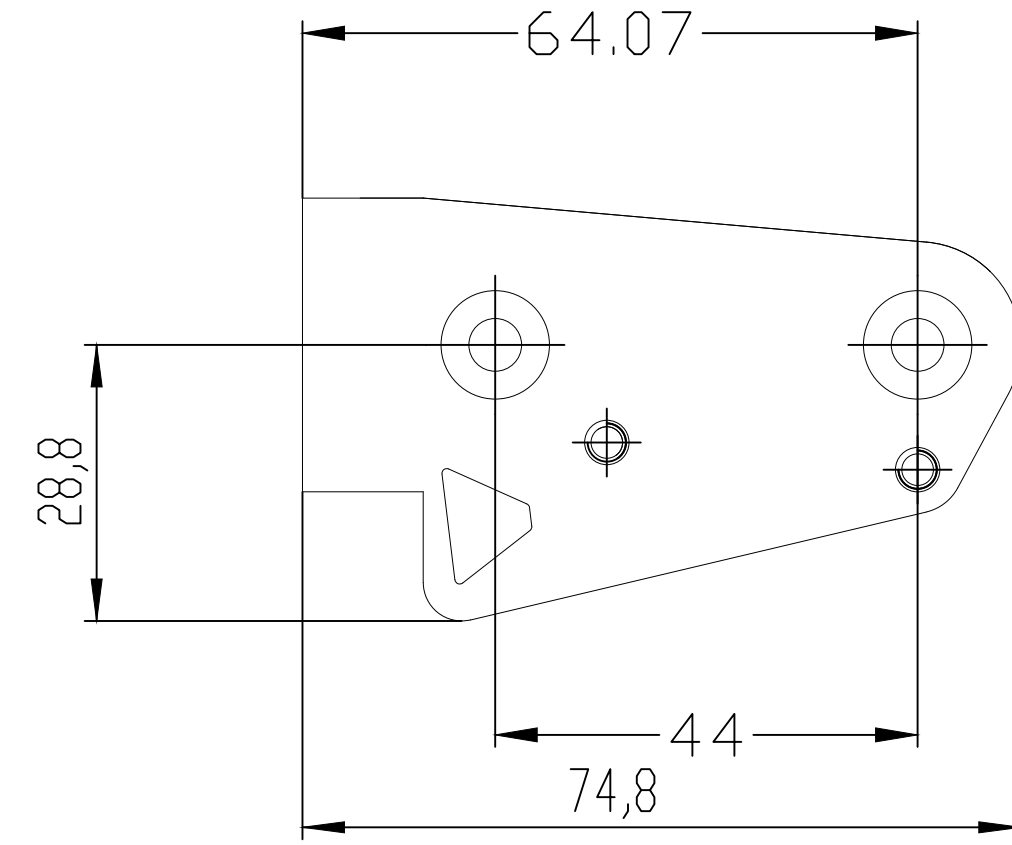
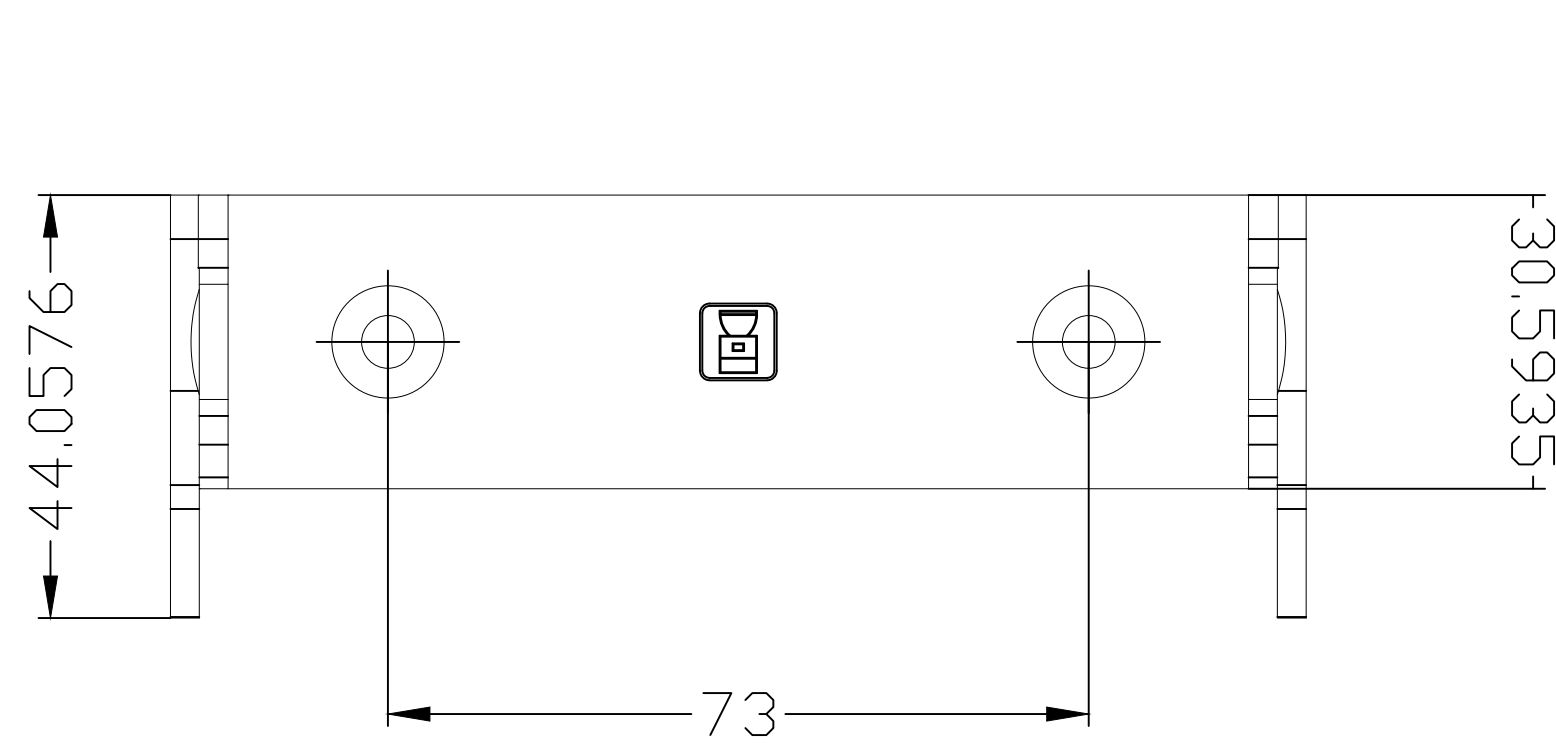

NOTE:  
1. DIMENSIONS ARE IN MM AND ARE FOR REFERENCE ONLY.

MUST COMPLY WITH ROCKWELL SPECIFICATION 910201

		CONFIDENTIAL AND PROPRIETARY INFORMATION. THIS DOCUMENT CONTAINS CONFIDENTIAL AND PROPRIETARY INFORMATION OF ROCKWELL AUTOMATION, INC. AND MAY NOT BE USED, COPIED OR DISCLOSED TO OTHERS, EXCEPT WITH THE AUTHORIZED WRITTEN PERMISSION OF ROCKWELL AUTOMATION, INC.	
DESCRIPTION	DATE	SHEET	OF
SafeZone CIP Scanner Mounting Bracket 1	2020-04-20	1	1
SIZE	DIR	VER	
D			
CREATED BY	SSHARM35	CHANGED BY	