

Bulletin 509 Three Phase Full Voltage Non-Reversing NEMA Starters
with Eutectic Alloy or Solid-State Overload Relays
Sizes 0 through 4 (all series), Size 5 (series L)
Renewal Parts

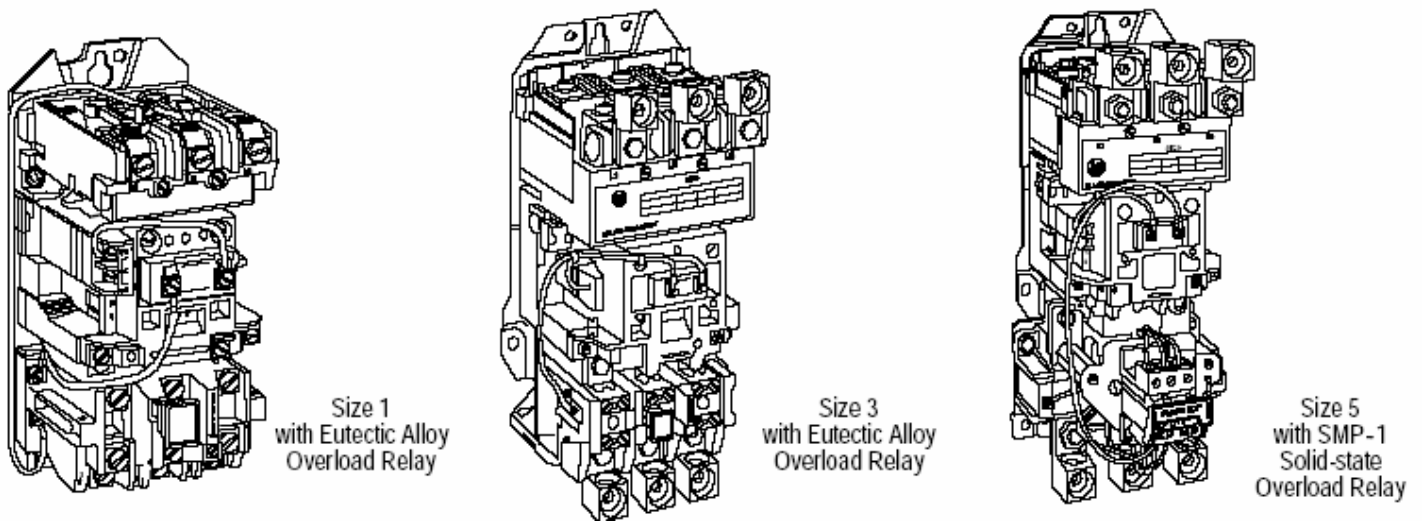
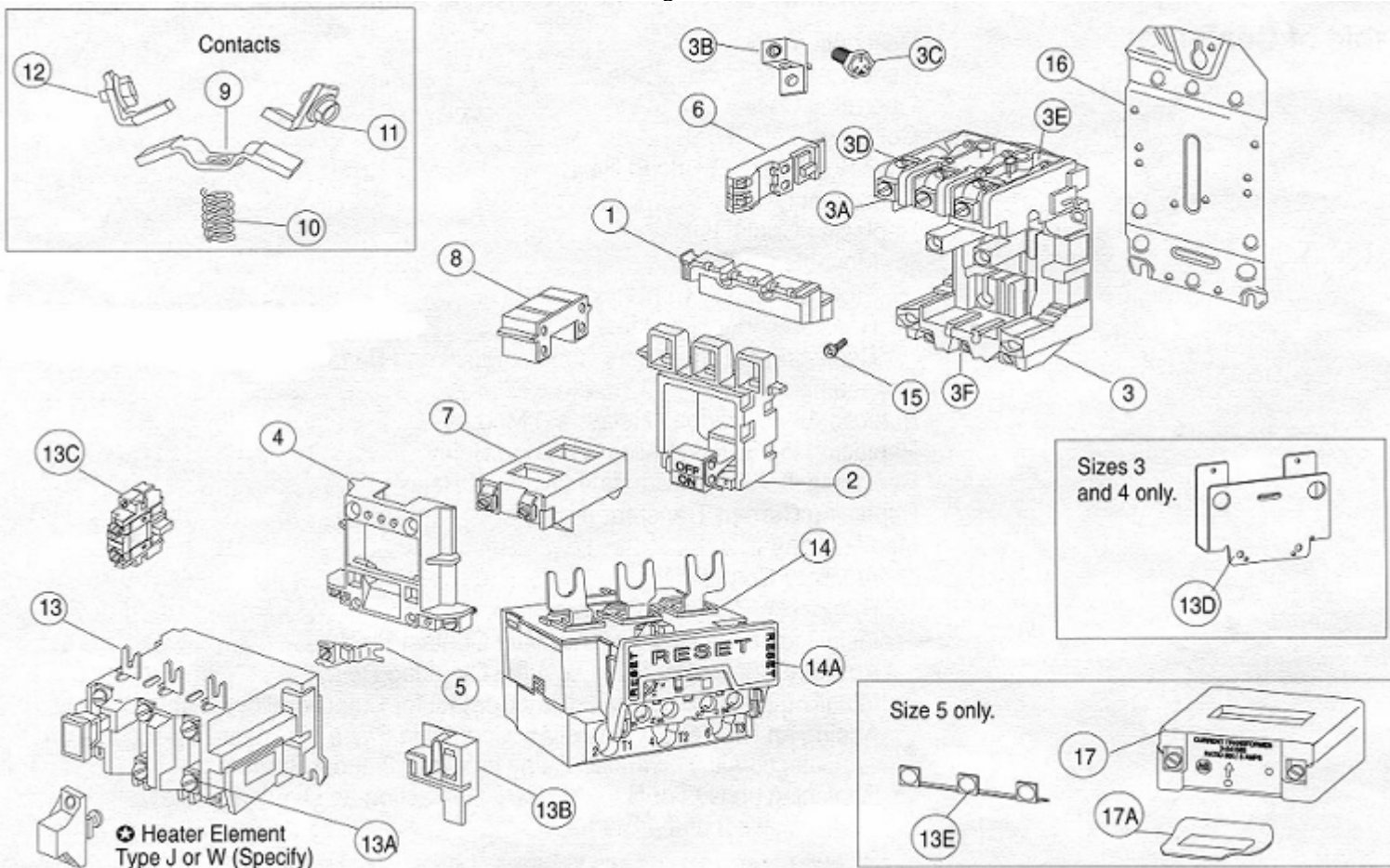

Figure 1 is an exploded view of the starter. Primary parts such as coils and contacts are similar in appearance for all sizes. Secondary parts such as mounting plates, overloads, etc. will vary in appearance. See page 2 for corresponding description of part and part numbers.

Figure 1



Renewal Parts, Bulletin 509, Three Phase, Sizes 0 through 4 (all series), Size 5 (series L)

Renewal Parts for Figure 1

Item	Description of Renewal Part	Size 0	Size 1	Size 2	Size 3	Size 4	Size 5 (Ser. L)
		Part No.	Part No.	Part No.	Part No.	Part No.	Part No.
1	Contact Block Cover	40410-499-01	40410-499-02	40420-499-01	40430-457-51	40440-456-51	42450-800-01
2	Movable Contact Support and Armature Assembly ①	40410-498-01 Series A 40410-498-03 Series B		40420-498-01	40430-452-51	40440-453-51	42450-801-01
3	Right Hand Stationary Contact Block and Base Assembly ①	40410-494-03	40410-494-04	40420-495-02	40430-462-52	40440-462-52	42450-307-62
3A	Saddle Clamp Assembly (lug)	X-225492		Does Not Apply			
3B	Lug	See Item 3A		X-316012	40430-461-51	40440-461-51	42450-804-01
3C	Bolt	See Item 3A		M-6289	M-6532	M-6834	Included in 3D
3D	Front Terminal without Contact	(See p. 5 for exploded view of Items 3D - 3F parts for nema sizes 3 through 5)			40430-022-02	40440-030-02	42450-302-52
3E	Rear Terminal without Contact				40430-024-02	40440-314-51	40440-314-51
3F	Front/Rear Terminal Screw				②		28168-107-26
4	Coil Cover	40410-496-01	40420-497-01	40430-454-51	40440-454-51	42450-803-01	
5	Tie Point Terminal	599-TP02			599-TP34		
6	Auxiliary Contact Block	595-A (used as a hold-in contact)					
7	Operating Coil	See table on page 4					
8	Yoke (50-60 Hz)	40410-497-01	40410-497-02	40430-455-51	40440-458-01		
9	Movable Contact	Order Single Pole Contact Set					
10	Contact Spring						
11	Front Stationary Contact						
12	Rear Stationary Contact						
9-12	Single Pole Contact Set (includes [1] each items 9-12) ⑦	40410-331-51	40410-331-52	40420-322-51	40430-300-51	40440-300-51	42450-805-01
13	Overload Relay (includes Item 13B)	42185-800-01		40185-800-01	40185-801-01	40185-802-01	592-BOV16 ④
13A	Heater Element Screw	M-1552					
13B	Test Module	40185-499-01			40430-459-51		42450-807-01
13C	Overload Relay Auxiliary Contact (included with item 13)	Not Available			595-A34 ⑤		Not Available
13D	Overload Relay Mounting Plate	See Item 16			40430-045-02	40440-028-02	42450-028-02
13E	Jumper (size 5 only)	Does Not Apply					42195-800-01
14	Solid-State Overload Relay	See pages 6 or 7					
14A	SMP/E1 Plus Reset Bar	40794-011-01 (for SMP) / 193-ERA (for E1 Plus)					
15	Mtg. Screw w/Washer (3 req'd)	28169-100-26	28169-101-26	40430-460-51	40440-459-51 ④		
16	Mounting Plate for Contactor and Overload Relay ⑥	40410-124-02	40420-083-02	40430-044-02	40440-027-02		
	Mounting Plate for SMP-3 ⑥	4074-031-02	40794-032-02				
17	Current Transformer	Does Not Apply					X-241563 ④
17A	Transformer Spring	Does Not Apply					42450-806-01 ④

- ① Less Contacts, order Single Pole Contact Set as required.
- ② Front and rear terminal assembly not available as a renewal part. Replace the complete stationary contact block and base assembly.
- ③ Front Terminal Screw Part No. is 28168-503-26 and Rear Terminal Screw Part No. is 28168-502-6.
- ④ For Size 5 starter a current transformer assembly (which includes items 13, 15, 17, and 17A) can be ordered as part number 42452-800-01.
- ⑤ Auxiliary mounted on right-hand side provides N.O. contact function., mounting on left-hand side provides N.C. contact function.
- ⑥ Overload relays, for sizes 0-2, are attached directly to the mounting plate. Overload Relays, for sizes 3-5, require a separate mounting plate. See Item 13D for sizes 3 and 4. Size 5 overload relay mounting plate is similar.
- ⑦ Bulletin 509 non-reversing starters have three power poles. Order as many single pole contact kits as needed.

Renewal Parts, Bulletin 509, Three Phase, Sizes 0 through 4 (all series), Size 5 (series L)

Renewal Parts for Control Circuit Terminals

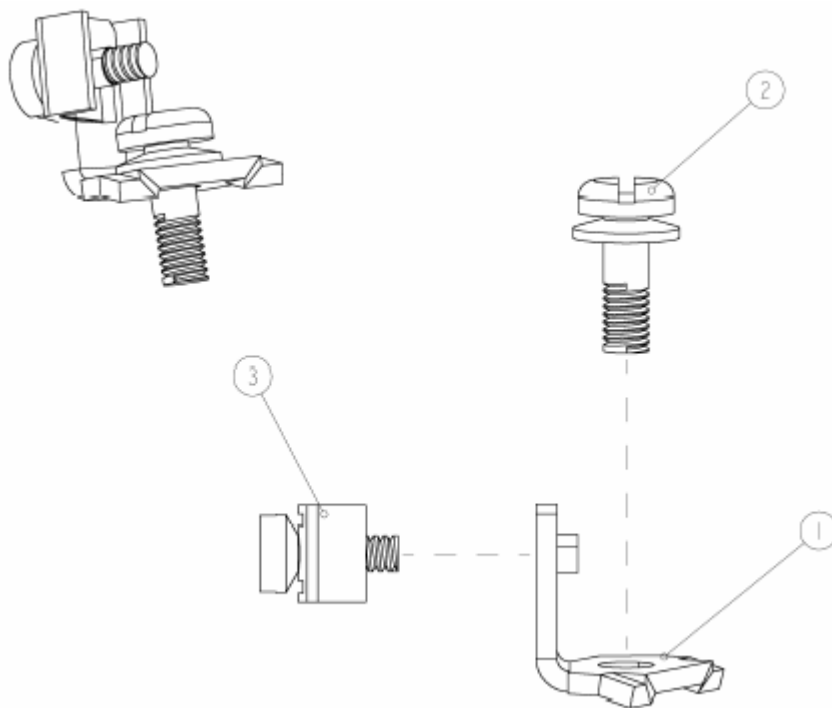

NEMA Size	Mounting Terminal (item 1)	Mounting Screw (Item 2)	Saddle Clamp Assembly (item 3)
0 - 2	40410-053-02	28158-072-26	28192-076-33
3	40430-047-02	M-6289	28192-076-33
4 - 5	40440-035-02	28168-676-26	28192-076-33

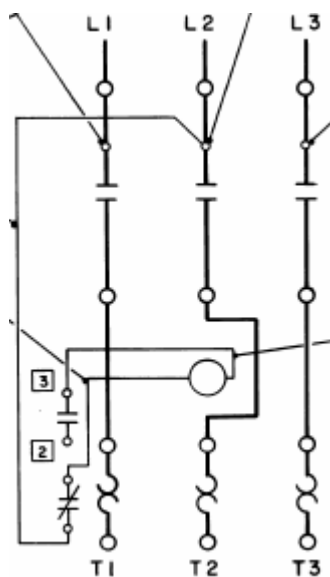

Renewal Parts, Bulletin 509, Three Phase, Sizes 0 through 4 (all series), Size 5 (series L)

Operating Coils

Catalog Number Suffix Code	AC Volts	Hz	Coil Repair Part Number				
			Size 0-1	Size 2	Size 3	Size 4	Size 5 (Series L)
J	24	60	CB013	CC013	CD013	NA	Not Available
K	24	50	CB407	CC407	CD407	NA	AF407
D	115-120 60Hz, 110V 50Hz		CB236	CC236	CD236	CE236	AF236
S	110-115	50	CB322	CC322	CD322	CE322	AF322
H	200-208	60	CB249	CC249	CD249	CE249	AF249
P	220-230	50	CB339	CC339	CD339	CE339	AF339
A	230-240	60	CB254	CC254	CD254	CE254	AF254
T	230-240	50	CB342	CC342	CD342	CE342	AF342
F	277	60	CB260	CC260	CD260	CE260	AF260
N	380	50	CB354	CC354	CD354	CE354	AF354
KN	380-400	50	CB390	CC390	CD390	CE390	AF390
I	415	50	CB357	CC357	CD357	CE357	AF357
Q	440-460	50	CB360	CC360	CD360	CE360	AF360
B	460-480	60	CB273	CC273	CD273	CE273	AF273
M	500	50	CB364	CC364	CD364	CE364	AF364
C	575-600	60	CB278	CC278	CD278	CE278	AF278

Size 5 Overload Relay Assembly with Current Transformers – Repair Part Number 42452-800-01

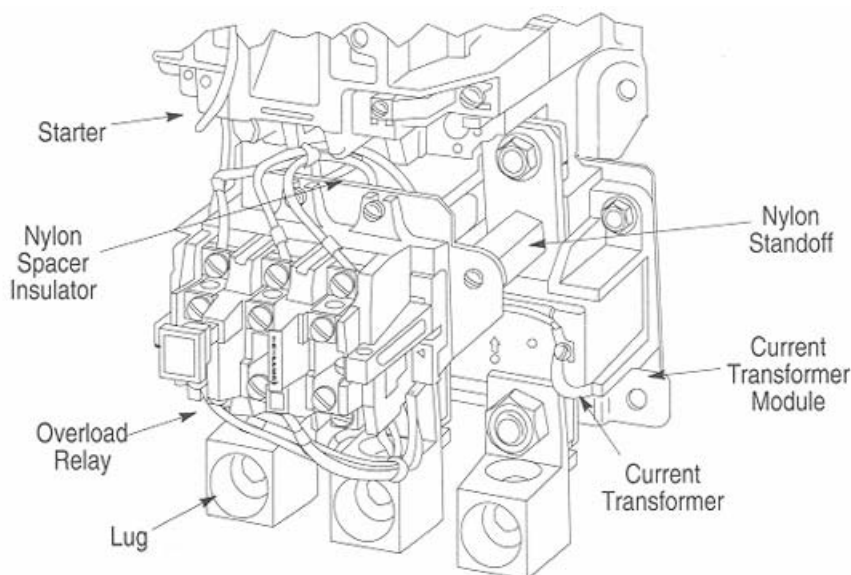

Components from Part Number 42452-800-01	Part Number
Nylon Spacer Insulator	42450-031-01
Overload Relay	592-BOV16
Overload Relay Mounting Plate (not labeled)	42450-028-02
Lug	42450-804-01
Nylon Standoff (qty 3 req'd)	42450-029-01
Current Transformer Module	42450-032-01
Current Transformer Module Mounting Plate (not labeled)	42450-009-02
Current Transformer (300 to 5A ratio) qty 3 req'd	X-241563

Renewal Parts, Bulletin 509, Three Phase, Sizes 0 through 4 (all series), Size 5 (series L)

Renewal Parts for Arc Hood Assembly Components – For Nema Sizes 3 and 4

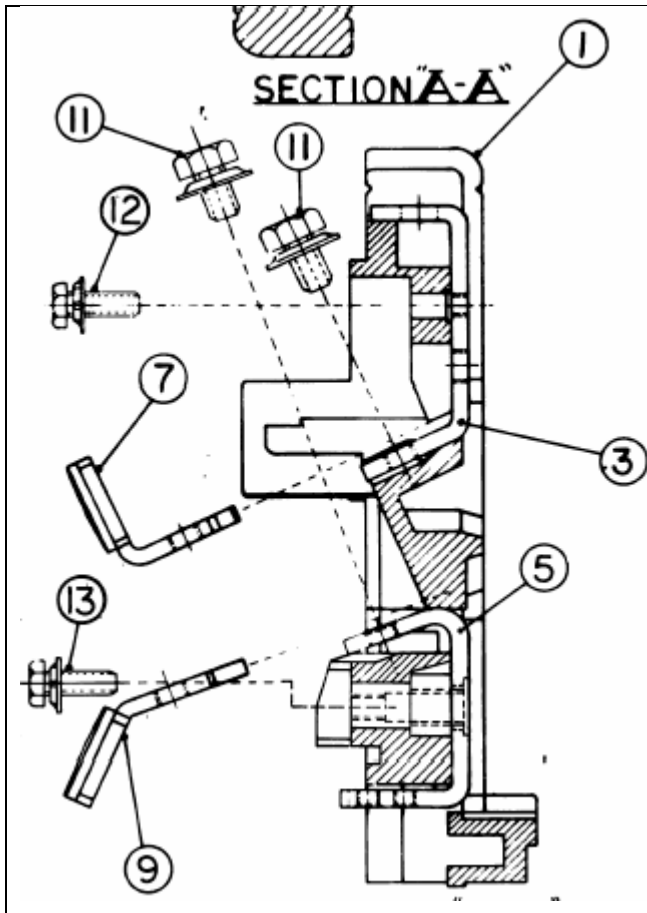

Renewal Parts for Nema Size 3 Starters		
Item #	Description	A-B Part Number ①
1	Arc Hood	Order Stationary Contact Block & Base Assembly (see p.2)
3	Front Terminal	40430-022-02
5	Rear Terminal	40430-024-02
7	Front Stationary Contact	Order Single Pole Contact Kit 40430-300-51
9	Rear Stationary Contact	
11	Screw for Front/Rear Contact	28168-601-26 ②
12	Screw for Front Terminal	28168-107-26
13	Screw for Rear Terminal	28168-107-26
Renewal Parts for Nema Size 4 Starters		
1	Arc Hood	Order Stationary Contact Block & Base Assembly (see p.2)
3	Front Terminal	40440-030-02
5	Rear Terminal	40440-314-51
7	Front Stationary Contact	Order Single Pole Contact Kit 40440-300-51
9	Rear Stationary Contact	
11	Screw for Front/Rear Contact	28168-676-26 ②
12	Screw for Front Terminal	28168-502-26
13	Screw for Rear Terminal	28168-502-26
① Each part number listed below contains one piece.		
② The screw for the front and rear stationary contacts is included in single pole contact kit part number(s) listed above.		

Renewal Parts for Arc Hood Assembly Components – For Nema Size 5

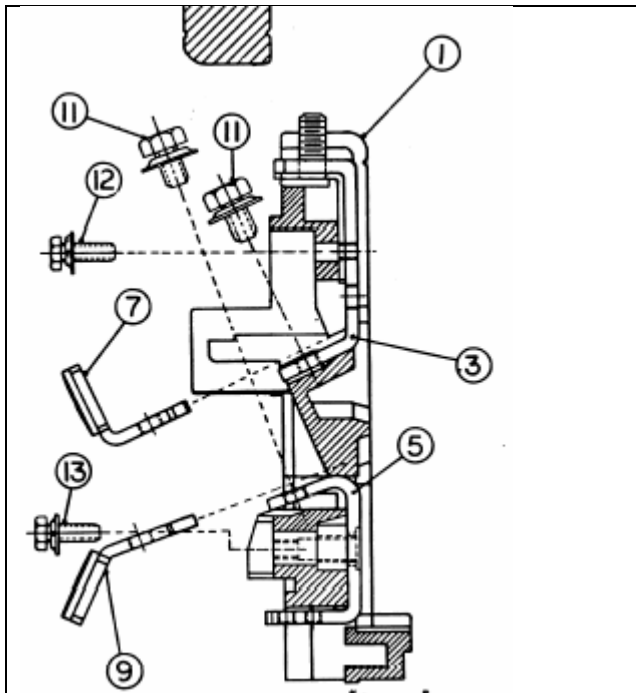

Item #	Description	A-B Part Number ①
1	Arc Hood	Order Stationary Contact Block & Base Assembly (see p.2)
3	Front Terminal	42450-302-51
5	Rear Terminal	40440-314-51
7	Front Stationary Contact	Order Single Pole Contact Kit 42450-805-01
9	Rear Stationary Contact	
11	Screw for Front/Rear Contact	28168-676-26 ②
12	Screw for Front Terminal	28168-503-21
13	Screw for Rear Terminal	28168-502-26
① Each part number listed below contains one piece.		
② The screw for the front and rear stationary contacts is included in single pole contact kit part number 42450-805-01.		

Renewal Parts, Bulletin 509, Three Phase, Sizes 0 through 4 (all series), Size 5 (series L)

(E1 Plus shown below)



E1 Plus/SMP Solid-State Overload Relays

Order the replacement overload relay catalog number from the table below. For example, the E1 Plus Class 10 overload relay for a 509-AOD-A1B would be ordered as catalog number 592-EEBC. The replacement overload part numbers are only for existing bulletin 509 starters that were ordered with a eutectic, SMP or E1 Plus overload. The part numbers below contain one overload relay. Nema Starter sizes 4 and 5 use the SMP overload relay.

Starter Size	Full Load Current Adjustment Range (A)	Class 10 Cat. No. Suffix Code	Class 10 Overload Cat. No.	Class 20 Cat. No. Suffix Code	Class 20 Overload Cat. No.	Class 30 Cat. No. Suffix Code	Class 30 Overload Cat. No.
E1 Plus/SMP-1 Overload Relay Manual Reset, Phase Loss Protection, Class 10, 15, 20, or 30							
0, 1	0.19 to 0.6	-A1B	592-EEBC	-A2B	592-EEBC	-A3B	592-EEBC
0, 1	0.32 to 1.0	-A1C	592-EEBC	-A2C	592-EEBC	-A3C	592-EEBC
0, 1	1.0 to 2.9	-A1D	592-EECC	-A2D	592-EECC	-A3D	592-EECC
0, 1	1.6 to 5.0	-A1E	592-EECC	-A2E	592-EECC	-A3E	592-EECC
0, 1	3.7 to 12	-A1F	592-EEDC	-A2F	592-EEDC	-A3F	592-EEDC
0, 1	5.7 to 18	-A1G	592-EEEC	-A2G	592-EEEC	-A3G	592-EEEC
1	12 to 38	-A1H	592-EEEC	-A2H	592-EEEC	-A3H	592-EEEC
2	5.7 to 18	-A1G	592-EEEC	-A2G	592-EEEC	-A3G	592-EEEC
2	12 to 38	-A1H	592-EEFC	-A2H	592-EEFC	-A3H	592-EEFC
2	14 to 45	-A1J	592-EEFC	-A2J	592-EEFC	-A3J	592-EEFC
3	14 to 45	-A1J	592-EEFD	-A2J	592-EEFD	-A3J	592-EEFD
3	23 to 75	-A1K	592-EEGD	-A2K	592-EEGD	-A3K	592-EEGD
3	66 to 110	-A1L	592-EEGD	-A2L	592-EEGD	-A3L	592-EEGD
4	23 to 75	-A1K	592-A1KE	-A2K	592-A2KE	-A3K	592-A3KE
4	66 to 110	-A1L	592-A1LE	-A2L	592-A2LE	-A3L	592-A3LE
4	57 to 180	-A1M	592-A1ME	-A2M	592-A2ME	-A3M	592-A3ME
5	96 to 300	-A1N	592-A1NF	-A2N	592-A2NF	-A3N	592-A3NF
E1 Plus/SMP-1 Overload Relay Automatic/Manual Reset, Phase Loss Protection, Class 10, 15, 20, or 30							
0, 1	0.19 to 0.6	-A4B	592-EEBC	-A5B	592-EEBC	-A6B	592-EEBC
0, 1	0.32 to 1.0	-A4C	592-EEBC	-A5C	592-EEBC	-A6C	592-EEBC
0, 1	1.0 to 2.9	-A4D	592-EECC	-A5D	592-EECC	-A6D	592-EECC
0, 1	1.6 to 5.0	-A4E	592-EECC	-A5E	592-EECC	-A6E	592-EECC
0, 1	3.7 to 12	-A4F	592-EEDC	-A5F	592-EEDC	-A6F	592-EEDC
0, 1	5.7 to 18	-A4G	592-EEEC	-A5G	592-EEEC	-A6G	592-EEEC
1	12 to 38	-A4H	592-EEEC	-A5H	592-EEEC	-A6H	592-EEEC
2	5.7 to 18	-A4G	592-EEEC	-A5G	592-EEEC	-A6G	592-EEEC
2	12 to 38	-A4H	592-EEFC	-A5H	592-EEFC	-A6H	592-EEFC
2	14 to 45	-A4J	592-EEFC	-A5J	592-EEFC	-A6J	592-EEFC
3	14 to 45	-A4J	592-EEFD	-A5J	592-EEFD	-A6J	592-EEFD
3	23 to 75	-A4K	592-EEGD	-A5K	592-EEGD	-A6K	592-EEGD
3	66 to 110	-A4L	592-EEGD	-A5L	592-EEGD	-A6L	592-EEGD
4	23 to 75	-A4K	592-A4KE	-A5K	592-A5KE	-A6K	592-A6KE
4	66 to 110	-A4L	592-A4LE	-A5L	592-A5LE	-A6L	592-A6LE
4	57 to 180	-A4M	592-A4ME	-A5M	592-A5ME	-A6M	592-A6ME
5	96 to 300	-A4N	592-A4NF	-A5N	592-A5NF	-A6N	592-A6NF

Renewal Parts, Bulletin 509, Three Phase, Sizes 0 through 4 (all series), Size 5 (series L)

(E1 Plus shown below)



E1 Plus/SMP Solid-State Overload Relays

Order the replacement overload relay catalog number from the table below. For example, the E1 Plus Class 10 overload relay for a 509-AOD-B1B would be ordered as catalog number 592-EEBC. The replacement overload part numbers are only for existing bulletin 509 starters that were ordered with a eutectic, SMP or E1 Plus overload. The part numbers below contain one overload relay. Nema Starter sizes 4 and 5 use the SMP overload relay. Add catalog numbers 193-EGM or 193-EJM to the E1 Plus catalog number if Ground Fault or Jam Protection is required. The E3/E3 Plus overloads include Ground Fault and Jam Protection, as standard, but must be configured via a DeviceNet network or a hand held programming terminal, with a continuous power source of 24V DC from a DeviceNet network or a power supply.

E1 Plus/SMP-2 Overload Relay Automatic/Manual Reset, Field Selectable Trip Class 10, 15, 20, or 30, Phase Loss, Jam Protection, and Ground Fault Protection				
Starter Size	Full Load Current Adjustment Range (A)	Catalog No. Suffix Code	Overload Relay Catalog No.	E1 Plus Ground Fault or Jam Module
0, 1	0.19 to 0.6	-B1B	592-EEBC	193-EGM or 193-EJM
0, 1	0.32 to 1.0	-B1C	592-EEBC	193-EGM or 193-EJM
0, 1	1.0 to 2.9	-B1D	592-EECC	193-EGM or 193-EJM
0, 1	1.6 to 5.0	-B1E	592-EECC	193-EGM or 193-EJM
0, 1	3.7 to 12	-B1F	592-EEDC	193-EGM or 193-EJM
0, 1	5.7 to 18	-B1G	592-EEEC	193-EGM or 193-EJM
1	12 to 38	-B1H	592-EEEC	193-EGM or 193-EJM
2	5.7 to 18	-B1G	592-EEEC	193-EGM or 193-EJM
2	12 to 38	-B1H	592-EEFC	193-EGM or 193-EJM
2	14 to 45	-B1J	592-EEFC	193-EGM or 193-EJM
3	14 to 45	-B1J	592-EEFD	193-EGM or 193-EJM
3	23 to 75	-B1K	592-EEGD	193-EGM or 193-EJM
3	66 to 110	-B1L	592-EEGD	193-EGM or 193-EJM
4	23 to 75	-B1K	592-B1KE	Included as standard
4	66 to 110	-B1L	592-B1LE	Included as Standard
4	57 to 180	-B1M	592-B1ME	Included as Standard
5	96 to 300	-B1N	592-B1NF	Included as Standard
E3 DeviceNet Overload Relay with Automatic/Manual Reset, Field Selectable Trip Class 10, 15, 20, or 30, Phase Loss, Jam Protection, with DeviceNet Communication Capability				
0, 1, 2	1.0 to 5.0	-EC1A	592-EC1AC	Included as Standard
0, 1, 2	3.0 to 15.0	-EC1B	592-EC1BC	Included as Standard
0, 1, 2	5.0 to 25.0	-EC1C	592-EC1CC	Included as Standard
0, 1, 2	9.0 to 45.0	-EC1D	592-EC1DC	Included as Standard
3	9.0 to 45.0	-EC1D	592-EC1DD	Included as Standard
3	18.0 to 90.0	-EC1E	592-EC1ED	Included as Standard
E3 Plus DeviceNet Overload Relay with Automatic/Manual Reset, Field Selectable Trip Class 10, 15, 20, or 30, Phase Loss, Jam Protection, and Ground Fault Protection with DeviceNet Communication Capability				
0, 1, 2	1.0 to 5.0	-EC2A	592-EC2AC	Included as Standard
0, 1, 2	3.0 to 15.0	-EC2B	592-EC2BC	Included as Standard
0, 1, 2	5.0 to 25.0	-EC2C	592-EC2CC	Included as Standard
0, 1, 2	9.0 to 45.0	-EC2D	592-EC2DC	Included as Standard
3	9.0 to 45.0	-EC2D	592-EC2DD	Included as Standard
3	18.0 to 90.0	-EC2E	592-EC2ED	Included as Standard

Important User Information

Because of the variety of uses for the products described in this publication, those responsible for the application and use of this control equipment must satisfy themselves that all necessary steps have been taken to assure that each application and use meets all performance and safety requirements, including any applicable laws, regulations, codes and standards.

The illustrations, charts, sample programs and layout examples shown in this guide are intended solely for purposes of example. Since there are many variables and requirements associated with any particular installation, Rockwell Automation does not assume responsibility or liability (to include intellectual property liability) for actual use based upon the examples shown in this publication.

Allen-Bradley publication SGI-1.1, *Safety Guidelines for the Application, Installation and Maintenance of Solid-State Control* (available from your local Allen-Bradley office), describes some important differences between solid-state equipment and electromechanical devices that should be taken into consideration when applying products such as those described in this publication.

Reproduction of the contents of this copyrighted publication, in whole or part, without written permission of Rockwell Automation, is prohibited.

Throughout this document we use notes to make you aware of safety considerations:

ATTENTION



Identifies information about practices or circumstances that can lead to personal injury or death, property damage or economic loss

IMPORTANT

Identifies information that is critical for successful application and understanding of the product.

Use only replacement parts and devices recommended by Rockwell Automation to maintain the integrity of the equipment. It is the user's responsibility to ensure that the renewal part number selected is properly matched to the model, series and revision level of the equipment being serviced.

ATTENTION



Servicing energized Industrial Control Equipment can be hazardous. Severe injury or death can result from electrical shock, burn, or unintended actuation of controlled equipment. Recommended practice is to disconnect and lockout control equipment from power sources, and release stored energy, if present.

Refer to **National Fire Protection Association Standard No. NFPA70E, Part 2 and (as applicable) OSHA rules for Control of Hazardous Energy Sources (Lockout/Tagout) and OSHA Electrical Safety Related Work Practices** for safety related work practices, including procedural requirements for lockout/tagout, and appropriate work practices, personnel qualifications and training requirements where it is not feasible to de-energize and lockout or tagout electric circuits and equipment before working on or near exposed circuit parts.

ROCKWELL DISCLAIMS ALL WARRANTIES WHETHER EXPRESSED OR IMPLIED IN RESPECT TO THE INFORMATION (INCLUDING SOFTWARE) PROVIDED HEREBY, INCLUDING THE IMPLIED WARRANTIES OF FITNESS FOR A PARTICULAR PURPOSE, MERCHANTABILITY, AND NON-INFRINGEMENT. Note that certain jurisdictions do not countenance the exclusion of implied warranties; thus, this disclaimer may not apply to you.