

| APPLICABLE MOTORS | |
|-------------------|---|
| MMI P/N | DESCRIPTION |
| 700-1308-01 | ASSY, MOTOR, 1000mm, SS RAILS, GEN4, ML |
| 700-1308-04 | ASSY, MOTOR, 1000mm, SS RAILS, SYNC, GEN4, ML |

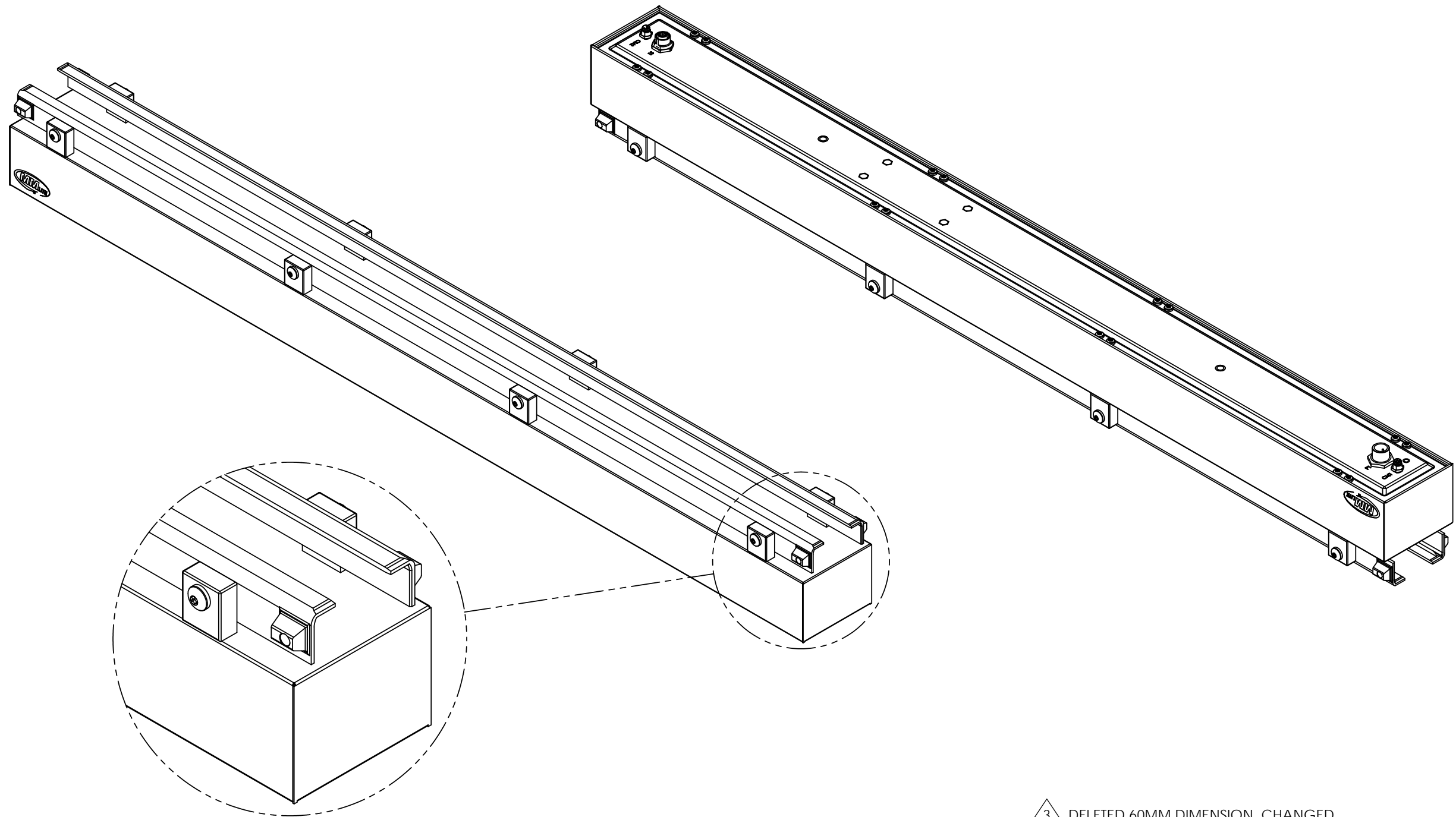

DETAIL A
SCALE 1 : 2

- 3 DELETED 60MM DIMENSION. CHANGED 95.3MM DIMENSION TO A LIMIT DIMENSION OF 95.2 - 96.2MM. (SEE ZONE C-1, SHEET 2)
- 2 CHANGED OVERALL WIDTH TOLERANCE, SHT 2
ADDED OVERALL ENCLOSURE LENGTH TOLERANCE, SHT 2

| | | |
|----------------------------|-------------------------------|---------------------------------------|
| UNLESS OTHERWISE SPECIFIED | | |
| ALL DIMENSIONS IN MM | SURFACE FINISH [63] 1.6 | TOLERANCES |
| BREAK ALL SHARP EDGES | | X.XX ± 0.13 |
| CLEAN AND DEBURR | | X.X ± 0.25 |
| USE MIN BEND RADII | | X ± 0.5 DEG ± 0.5° TORQUE ± 25% |

MAGNEMOTION CONFIDENTIAL
Copyright© 2012 MagneMotion Inc.
The information contained in this drawing is the sole property of MagneMotion Inc. Any reproduction in part or whole without the written permission of MagneMotion is prohibited

| | | | |
|--|------------------------|-----------------------|-------------------|
| INTERPRET DRAWING PER ANSI Y14.5M-1982 | | | |
| DO NOT SCALE DRAWING | SHEET SIZE B | PROJECT ML | DATE 2011-12-01 |
| CAD PKG. SolidWorks 2011 | SCALE 1:1 | ENGINEER J MENDENHALL | DRAWN BY J. SYIEK |
| CAD FILE 701-1308-04.SLDDRW | THIRD-ANGLE PROJECTION | | |

MagneMotion Inc.
139 Barnum Road
Devens, MA 01434 USA
(978) 757-9100

| | |
|---|--------------|
| TITLE ICD, MOTOR, 1000MM, SS RAILS, GEN4, ML | REV 3 |
| MATERIAL SEE BOM | |
| DWG NO. 701-1308-04 | SHEET 1 OF 2 |

CAGE CODE 1LR11

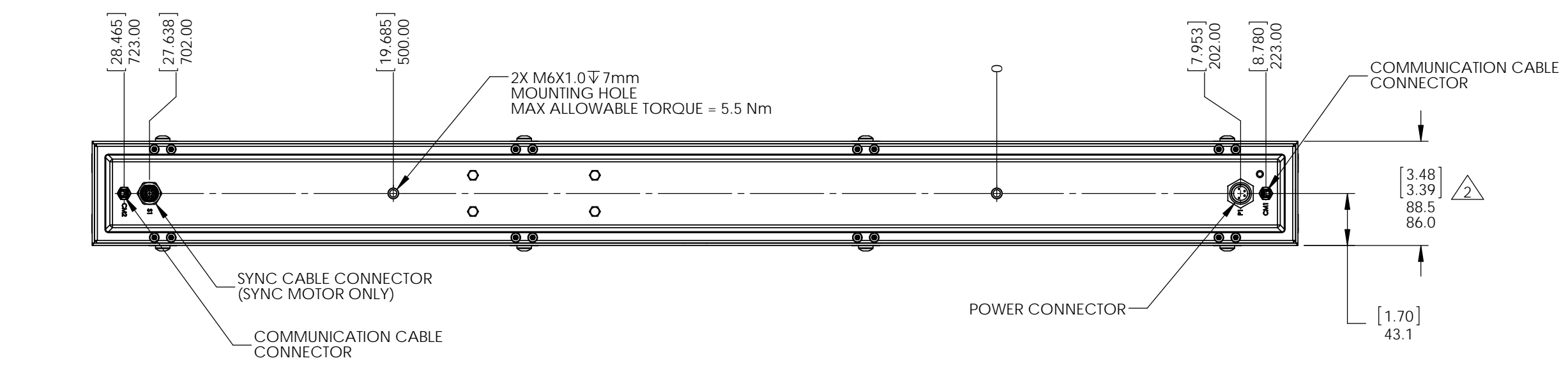
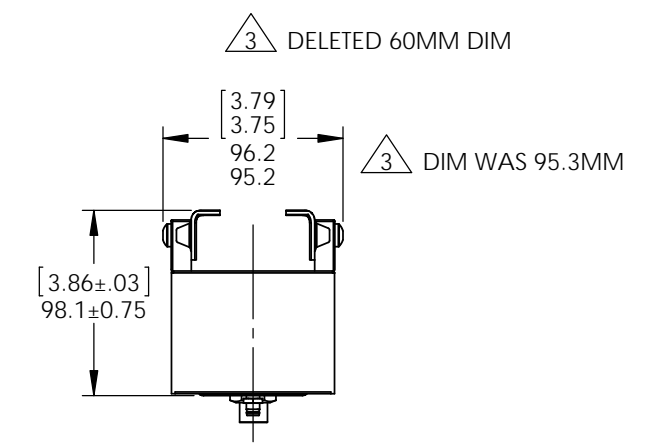
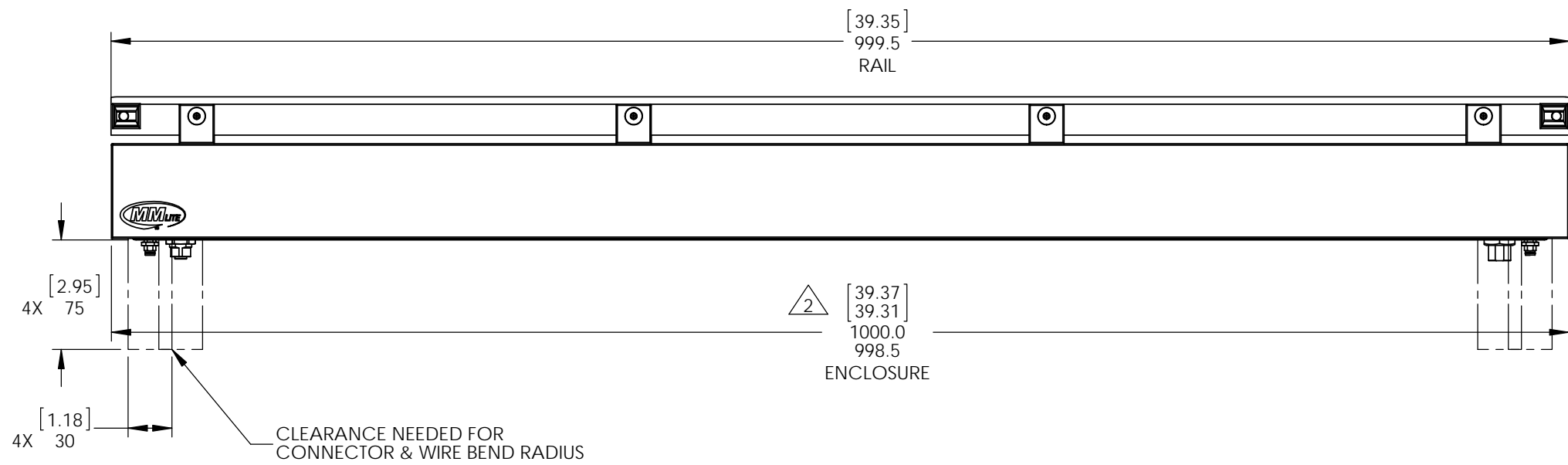

MagneMotion Inc.
 139 Barnum Road
 Devens, MA 01434 USA
 (978) 757-9100

| | | | |
|----------|--|-----|--------------|
| TITLE | ICD, MOTOR, 1000MM, SS RAILS, GEN4, ML | REV | 3 |
| MATERIAL | SEE BOM | | |
| DWG NO. | 701-1308-04 | | |
| | | | SHEET 2 OF 2 |