

CLEARANCE NEEDED FOR CONNECTOR & WIRE BEND RADIUS

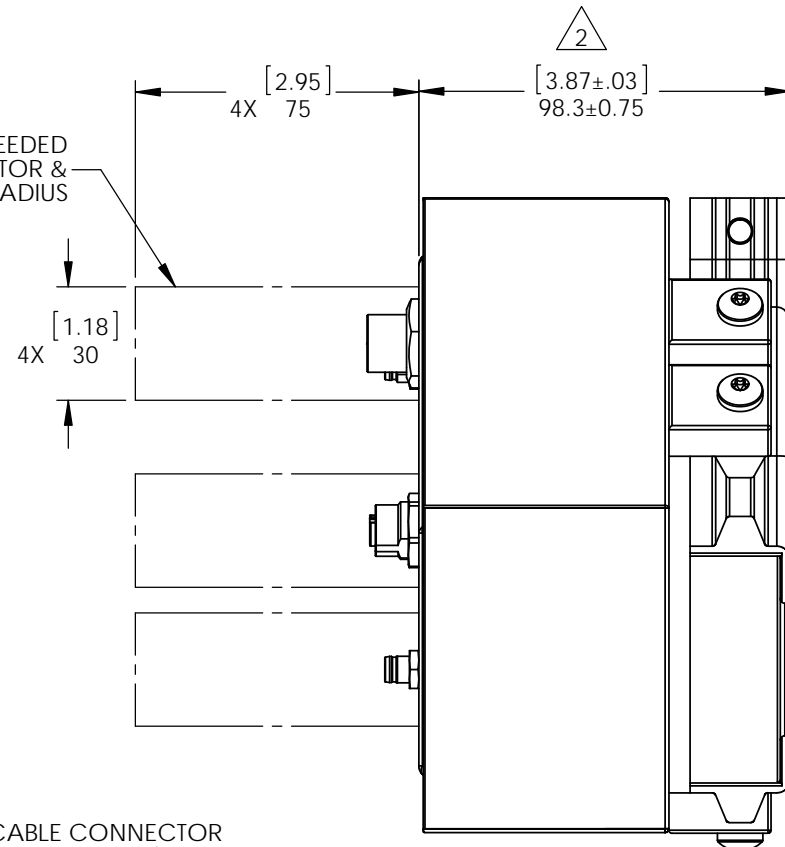

[3] DELETED 60MM DIMENSION.

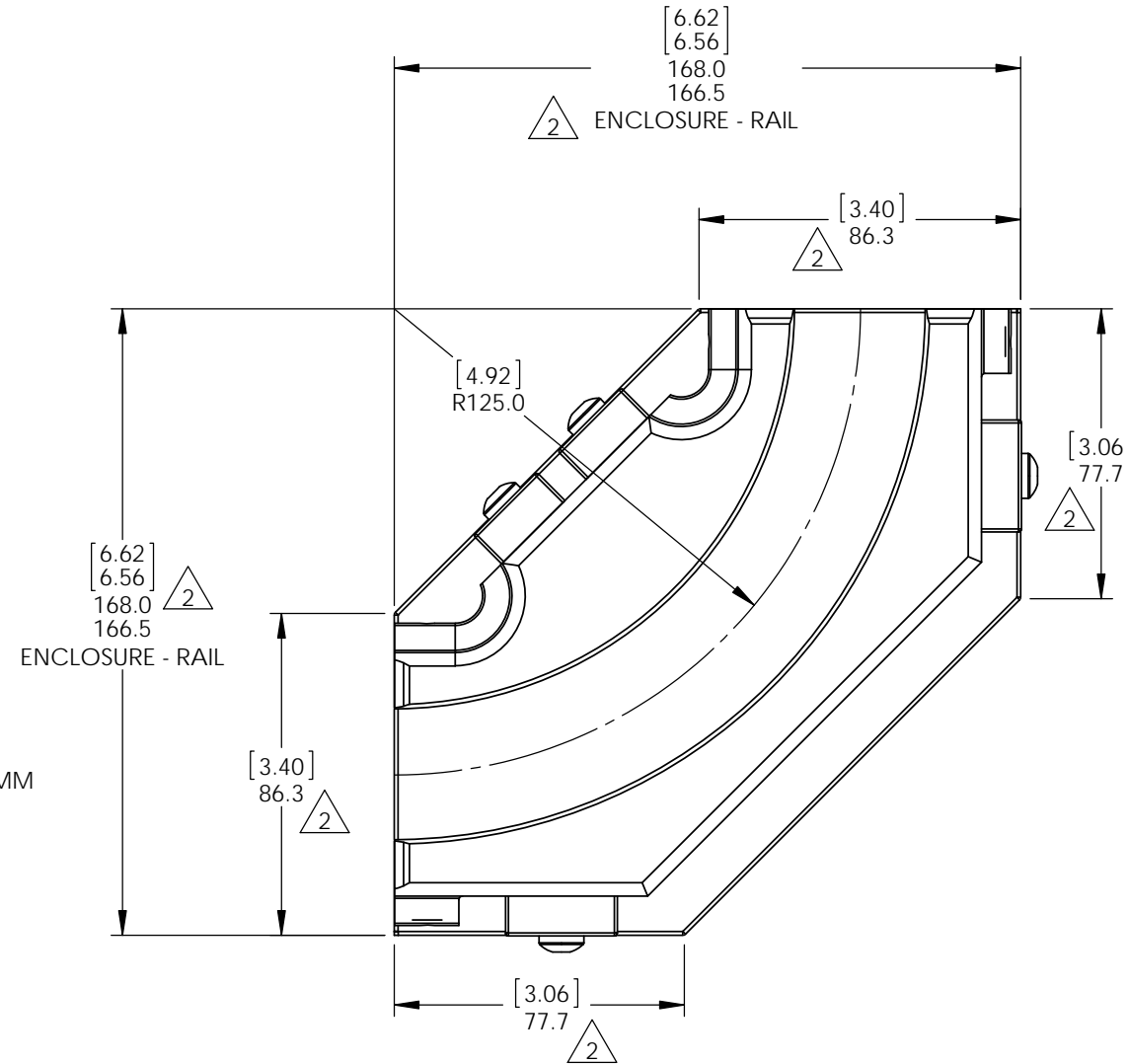

**MagneMotion Inc.**  
139 Barnum Road  
Devens, MA 01434 USA  
(978) 757-9100

|          |                                       |              |   |
|----------|---------------------------------------|--------------|---|
| TITLE    | ICD, MOTOR, CURVE, AL RAILS, GEN4, ML | REV          | 3 |
| MATERIAL |                                       |              |   |
| DWG NO.  | 701-1308-43                           | SHEET 2 OF 2 |   |