



PowerFlex 755 On-Machine Drive

Catalog Number 26G



Allen-Bradley

by ROCKWELL AUTOMATION

User Manual

Original Instructions

Important User Information

Read this document and the documents listed in the additional resources section about installation, configuration, and operation of this equipment before you install, configure, operate, or maintain this product. Users are required to familiarize themselves with installation and wiring instructions in addition to requirements of all applicable codes, laws, and standards.

Activities including installation, adjustments, putting into service, use, assembly, disassembly, and maintenance are required to be carried out by suitably trained personnel in accordance with applicable code of practice.

If this equipment is used in a manner not specified by the manufacturer, the protection provided by the equipment may be impaired.

In no event will Rockwell Automation, Inc. be responsible or liable for indirect or consequential damages resulting from the use or application of this equipment.

The examples and diagrams in this manual are included solely for illustrative purposes. Because of the many variables and requirements associated with any particular installation, Rockwell Automation, Inc. cannot assume responsibility or liability for actual use based on the examples and diagrams.

No patent liability is assumed by Rockwell Automation, Inc. with respect to use of information, circuits, equipment, or software described in this manual.

Reproduction of the contents of this manual, in whole or in part, without written permission of Rockwell Automation, Inc., is prohibited.

Throughout this manual, when necessary, we use notes to make you aware of safety considerations.



WARNING: Identifies information about practices or circumstances that can cause an explosion in a hazardous environment, which may lead to personal injury or death, property damage, or economic loss.



ATTENTION: Identifies information about practices or circumstances that can lead to personal injury or death, property damage, or economic loss. Attentions help you identify a hazard, avoid a hazard, and recognize the consequence.

IMPORTANT Identifies information that is critical for successful application and understanding of the product.

Labels may also be on or inside the equipment to provide specific precautions.



SHOCK HAZARD: Labels may be on or inside the equipment, for example, a drive or motor, to alert people that dangerous voltage may be present.



BURN HAZARD: Labels may be on or inside the equipment, for example, a drive or motor, to alert people that surfaces may reach dangerous temperatures.



ARC FLASH HAZARD: Labels may be on or inside the equipment, for example, a motor control center, to alert people to potential Arc Flash. Arc Flash will cause severe injury or death. Wear proper Personal Protective Equipment (PPE). Follow ALL Regulatory requirements for safe work practices and for Personal Protective Equipment (PPE).

	Preface	
	Summary of Changes	7
	Conventions Used in This Manual	7
	Additional Resources	8
	Chapter 1	
Getting Started	System Overview	11
	System Identification Diagram	12
	Data Nameplate and UL Listing	12
	System Configuration Example	13
	ArmorConnect Power Media	15
	Catalog Number Explanation	16
	Chapter 2	
Prepare for Installation	Precautions	17
	Electrical Safety Considerations	19
	Environment and Enclosure	19
	Environment	20
	Wiring and Workmanship Guidelines	20
	Electromagnetic Compatibility (EMC)	21
	General Notes	21
	Wiring	22
	Power Requirements	22
	Circuit Protection	23
	Short-circuit current rating (SCCR)	24
	Circuit Breakers	24
	Branch Circuit Protection Requirements for Three-Phase Power Media	25
	Minimum Mounting Clearances	26
	Dimensions	27
	Receive, Unpack, and Inspect the Drive	28
	Receiving	28
	Unpack and Inspect	30
	Lift and Transport the Drive	31
	Two-Person Lifting	33
	Apply Labels to the Drive	34
	Chapter 3	
Install the Drive	Mount the Drive	35
	Ground the Drive	36
	Grounding Safety Grounds	37
	Grounding PE or Ground	38
	Shield and Ground Motors and Motor Cables	38
	Select Cables	38
	Control Power	44

24V DC Control Power Receptacle 44
 Make Connections 44
 Receptacle Configurations on the Gland Plate 44
 Receptacle Connections..... 47

Chapter 4

Configure and Start Up the Drive

Prepare for Initial Drive Start Up..... 50
 Set the Network IP Address of the 1783-ETAP..... 50
 Configure the PowerFlex 755 Drive Embedded
 EtherNet/IP Adapter..... 51
 Energize the HIM..... 51
 Use the PowerFlex 20-HIM-C6S HIM to Access Parameters.. 53
 Set the Adapter IP Address..... 53
 Start Up Introduction 56
 Controller Organizer 56
 Add-on Profiles 57
 Configuration Requirements 57
 Choose Start Up Mode 58
 Drive Start Up – I/O Mode..... 59
 Add the PowerFlex 755 Drive to Your Project 60
 Update the Module Properties..... 63
 Verify Drive Data..... 66
 Choose Integrated or Hard-wired Safety..... 67
 Safety Configuration for SSM and S4 69
 Configure the Drive Parameters 72
 Setup the Datalinks..... 85
 Create Safety Logic to Control the Safety Module..... 86
 Configure an RS Trend 88
 Save and Download Project..... 92
 Go Online with the Logix Controller 93
 Put the Logix Controller Into Run Mode..... 95
 Turn Safety On (SSM and S4 Only)..... 96
 Energize the Incoming Power and Brake Circuit Breakers..... 96
 Perform Motor Auto Tune Tests 97
 Application Tuning..... 108
 Connect the Motor to the Machine 109
 Synchronize the Drive 110
 Application Notes 111
 Drive Start Up – Integrated Motion mode (CIP Motion) 112
 Add Drive to the I/O Project..... 112
 Select Peripheral Devices and Slot Assignments for
 Option Modules 114
 Create an Associated Axis 116
 Configure the Axis Properties, the Associated Axis,
 and Control Mode..... 127
 Specify the Motor Data Source 130
 Create a Safety Program to Control the Drive Safety Circuits 135

Save and Download the Project	135
Verify the Controller Is Online	137
Commission and Tune the Motor and Drive.....	138
Autotune	142
Manual Tune	143
Save Commissioned Axis to the Logix Project.....	144

Chapter 5

Drive Maintenance

Repair and Replacement Procedures	146
Remove Power	147
Remove the Front Cover.....	148
Replace the Surge Suppressor AC Source Brake (1SUP270).....	150
Replace the DC Brake Surge Suppressor (1BD0270)	151
Replace the Brake Contactor (5BC130).....	152
Replace the Main Circuit Breaker (1CB030)	153
Replace PowerFlex Frame 2 Drive (1EA030)	156
Replace the PowerFlex Frame 2 Heatsink Fan.....	160
Replace Option Modules.....	160
Replace the Auxiliary Circuit Breakers (5CB070 and 1CB250 or 5CB130).....	161
Replace the Drive HIM (1HIM320).....	162
Replace the EMC Kit (1CH030)	163
Replace the ETAP Module (6ET210).....	163
Replace Receptacles on the Gland Plate	164
Receptacle Replacement - Type 1	166
Receptacle Replacement - Type 2	166
Receptacle Replacement - Type 3	167
Receptacle Replacement - Type 4	167
Receptacle Replacement - Type 5	168
Receptacle Replacement - Type 6	168
Attach the Front Cover.....	169
Apply Power.....	170

Chapter 6

Troubleshooting

Electrical Safety Considerations	173
Fault Types, Descriptions, and Actions.....	174
Circuit Breaker Troubleshooting	176
Open Auxiliary Circuit Breaker Door	176
Reset Drive via the Circuit Breaker Switch.....	177
Encoder Feedback Considerations	179
Potential Encoder Feedback Issues	179
Encoder System Components	180
Mechanical Checks	181
Positioning Troubleshooting Flowcharts	182
Troubleshooting Going Online.....	185
View Adapter Status By Using Parameters	185

	Access the Adapter Web Pages.....	185
	Set a Fault Action	188
	Restore Adapter Parameters to Default Configurations	190
	Updating the Drive Firmware	191
	Chapter 7	
Periodic and Preventative Maintenance	Recommended Preventive Maintenance.....	195
	Schedule Codes Explanations.....	196
	Maintenance of Industrial Control Equipment	197
	Appendix A	
Spare Parts Directory	Induction Motor 400/480 AC Source Brake	203
	Induction Motor 24V DC Mechanical Brake	204
	Servo Motor 24V DC Mechanical Brake	205
	Gland Plate Receptacles.....	206
	Appendix B	
Start Up Information	Prepare for Initial Drive	
	Start Up.....	207
	Index	209

This publication provides basic information to install, connect, and maintain the PowerFlex® 755 On-Machine™ drives.

For information on programming, troubleshooting, safety application requirements, and EtherNet/IP networks, see the publications that are listed in the [Additional Resources on page 8](#).

This manual is intended for qualified personnel. You must be able to program and operate adjustable frequency AC drives. In addition, you must have an understanding of the parameter settings and functions.



ATTENTION: This manual is intended for qualified service personnel responsible for installing and servicing these devices. You must have previous experience and a basic understanding of electrical terminology, configuration procedures, required equipment, and safety precautions.

Summary of Changes

The following changes apply to this revision of the manual.

Change	See Page(s)
Added factory installed battery information	22
Updated CH4 start up procedure to include S4 start up	56
Updated maintenance procedures to reflect drive modifications	145
Added Type 6 connector maintenance	168

Conventions Used in This Manual

These conventions are used throughout this manual:

- Where a parameter is referenced, it is referenced as Port#:Parameter# [parameter name].
Example (00:301 [Net Addr Scr] or 10:350 - [Vref Source])
- Where groups of parameters are referenced, the Port# is stated in text before the group.
- All Port#:Parameter# [parameter name] referenced are listed in bold.

For more information on parameters and their functions, see PowerFlex 750-Series AC Drives Programming Manual, publication [750-PM001](#).

Additional Resources

The following publications provide general product information.

Resource	Description
Bulletin 140G Flexible Cable Oper Mech-140G-G, 140G-H, 140G-I, 140G-J, 140G-K, publication 140G-IN128	Installation instruction for Flex Cable Operator for 140G-G through K.
Industrial Automation Wiring and Grounding Guidelines, publication 1770-4.1	Provides general guidelines for installing a Rockwell Automation® industrial system.
Logix 5000 Controllers I/O and Tag Data Programming Manual, publication 1756-PM004	This manual shows how to access I/O and tag data in Logix 5000™ controllers.
ArmorConnect Power and Control Media Selection Guide, publication 280PWR-SG001	This manual describes how to select the ArmorConnect® power and control media cables.
PowerFlex 755 On-Machine Drive Specification Technical Data, publication 750-TD003	Provides detailed information on: <ul style="list-style-type: none"> • Drive specifications • Option specifications • Fuse and circuit breaker ratings
Guarding Against Electrostatic Damage, publication 8000-SB001	This data sheet explains the causes of ESD, and how you can guard against its effects.
Wiring and Grounding for Pulse Width Modulated (PWM) AC Drives, publication DRIVES-IN001	This manual provides basic information to install, protect, wire, and ground pulse-width modulated (PWM) AC drives. This manual is intended for qualified personnel who plan and design installations of PWM AC drives.
Integrated Motion on the EtherNet/IP Network Reference Manual, publication MOTION-RM003	Use this manual to review descriptions of the AXIS_CIP_DRIVE attributes and the Logix Designer application Control Modes and Methods. It is intended for use as a reference when programming motion applications
Product Certifications website, http://rok.auto/certifications	Provides declarations of conformity, certificates, and other certification details.
Connected Components Workbench website http://www.ab.com/support/abdrives/webupdate/software.html , and online help ⁽¹⁾	The Connected Components Workbench® software tool. Includes a link for free software download.
Product Compatibility Download Center https://compatibility.rockwellautomation.com/Pages/home.aspx	The Product Compatibility and Download Center (PCDC) can help you find product-related downloads including firmware, release notes, associated software, drivers, tools, and utilities.

(1) The online help is installed with the software.

The following publications provide setup information.

Resource	Description
Logix 5000 Controllers Common Procedures Programming Manual, publication 1756-PM001	This publication links to a collection of programming manuals that describe how you can use procedures that are common to all Logix5000 controller projects.
Logix 5000 Controllers Ladder Diagram Programming Manual publication 1756-PM008	This manual shows how to program Logix 5000 controllers with the relay ladder programming language. This manual is one of a set of related manuals that show common procedures for programming and operating Logix 5000 controllers.
Ethernet Tap, publication 1783-PC011	Provides detailed information on setting the IP address using the 1783-ETAP.
PowerFlex 7-Class Enhanced Remote HIM, publication 20HIM-IN005	Provides dimensions and installation instructions for a 20HIM.
PowerFlex 20-HIM-A6/-C6S HIM (Human Interface Module) User Manual, publication 20HIM-UM001	Provides detailed information on HIM components, operation, and features.
PowerFlex 755 Drive Embedded EtherNet/IP Adapter User Manual, publication 750COM-UM001	This manual provides information about the EtherNet/IP adapter that is embedded on the main control board in PowerFlex® 755 drives, and how to use it for network communication.

Resource	Description
PowerFlex 750-Series Configuration with Permanent Magnet Motors Application, publication 750-AT004	This document contains methodologies for the proper test and setup of PM motors with the PowerFlex 755 drive, using PM flux vector (FV) mode, and the PowerFlex 750-Series drives using iPM FV mode.
PowerFlex 750-Series AC Drives Installation Instructions, publication 750-IN001	This document explains the basic steps for mechanical installation and for connecting incoming power, the motor, and basic I/O to the PowerFlex 750-Series Adjustable Frequency AC drive.
PowerFlex 755 On-Machine Drive Packing Instructions, publication 750-PC004	This document contains a high level view of the installation and unpacking instructions for the PowerFlex 755 On-Machine Drive.
PowerFlex 750-Series Drive Programming Manual, publication 750-PM001	Provides detailed information on: <ul style="list-style-type: none"> • I/O, control, and feedback options • Parameters and programming • Faults, alarms, and troubleshooting
PowerFlex 750-Series AC Drives Quick Start, publication 750-QS001	This Quick Start publication is designed to guide you through the 6 BASIC STEPS that are required to start up your PowerFlex 750-Series AC drive for the first time for simple applications.
PowerFlex 750-Series AC Drives Technical Data, publication 750-TD001	Provides detailed information on: <ul style="list-style-type: none"> • Drive specifications • Option specifications • Fuse and circuit breaker ratings
PowerFlex 755/755T Integrated Safety - Safe Torque Off Option Module (S3), publication 750-UM004	These publications provide detailed information on how to install, configure, and operate the 750-Series safety option modules.
PowerFlex 755/755T Integrated Safety Functions Option Module (S4), publication 750-UM005	
EtherNet/IP Network Configuration User Manual, publication ENET-UM006	This manual describes how to use EtherNet/IP communication modules in Logix 5000 control systems.
Integrated Motion on the EtherNet/IP Network: Configuration and Startup, publication MOTION-UM003	Configure an integrated motion on the EtherNet/IP network application and start up your motion solution with a Logix controller-based system.
Motion System Tuning Application Techniques, publication MOTION-AT005	The purpose of this publication is to assist you in tuning a Kinetix drive system. This document is intended for motion control users with novice to advanced skill levels that are familiar with the following: <ul style="list-style-type: none"> • Kinetix servo drives • Servos or EtherNet/IP communication • Use of the Logix Designer application to create a motion axis • Understanding how control loops work in motion control applications Each component of the control structure is described in detail and out-of-box tuning, autotuning, and manual tuning techniques are presented.

The following publications provide maintenance information.

Resource	Description
1321-M055 Common Mode Choke, publication 1321-IN002	Provides instructions on replacing a common mode choke in a PowerFlex 750-Series frame 1...7 drive.
PowerFlex 750-Series EMC Cores - Frames 1...5 Installation Instructions, publication 750-IN007	Provides instructions on replacing EMC Cores in PowerFlex 750-Series frame 1...5 drives.
PowerFlex 750-Series EMC Plate and Cores - Frames 1...7 Installation Instructions, publication 750-IN006	Provides instructions on replacing EMC Cores and Plates in PowerFlex 750-Series frame 1...7 drives.
PowerFlex 750-Series Option Modules Installation Instruction, publication 750-IN002	These instructions cover the installation of the option modules.
PowerFlex 750-Series Fan Replacement Kits Installation Instructions, publication RA-IN027	This manual describes how to replace the fan on the PowerFlex 755 frame 2 drive.

You can view or download publications at rok.auto/literature.

Getting Started

Topic	Page
System Overview	11
System Configuration Example	13
ArmorConnect Power Media	15
Catalog Number Explanation	16

System Overview

The PowerFlex® 755 On-Machine™ Drive is a small footprint UL Type 12 / IP66 (indoor use only) enclosure. It offers several configurations for encoder feedback, Safe Torque Off, and the Network Integrated Safety Function. The product also includes quick-connect connections for: I/O, power, motor, safety, encoder feedback, positioning, communication, and brake connectors on the bottom gland plate.

The drive is designed for automotive and material handling customer applications, including: cart transfer tables, framers, power roll beds, trunnions, turntables, and vertical lifts.

The EtherNet/IP® communication utilized by the drive allows use with the following network topologies: linear, star, and Device Level Ring (DLR).

There are two safety options available for the drive:

- Safe Torque Off (20-750-S3) - Safe torque off for safety-related applications that require the removal of rotational power to the motor without shutting down the drive.
- Network Integrated Safety Function (20-750-S4) - The integrated safety function option combines Safe Torque Off capability and the safe speed control technology in one hardware option.

IMPORTANT The safety option module is intended to be part of the safety-related control system of a machine. Before installation, perform a risk assessment to determine whether the specifications of this safety option module are suitable for all foreseeable operational and environmental characteristics of the system. The software versions that are required for the two available safety options are different. See the [Additional Resources on page 8](#) section for more information on the safety manuals.

System Identification Diagram

The following image identifies the location and name of other important items of the drive.

Figure 1 - System Identification Diagram

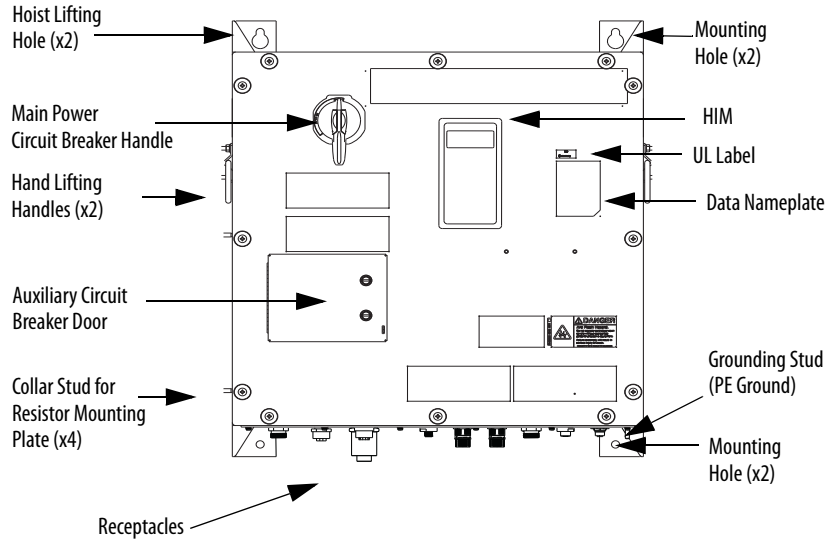

Data Nameplate and UL Listing

The drive has two data nameplates that are attached to the enclosure. One nameplate is located inside the enclosure in the upper-right-hand corner, and the other is on the front cover. The UL label that contains the product rating is located on the front cover near the data nameplate. The UL listing on the data nameplate relates to the enclosure rating. See [System Overview on page 11](#) for the location of the data nameplate that is on the front cover.

IMPORTANT You do not need to remove the cover to verify the interior nameplate.

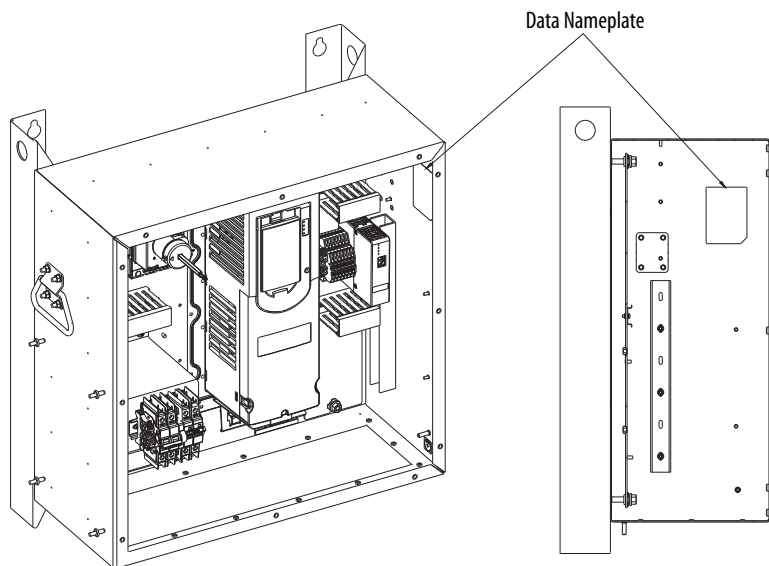

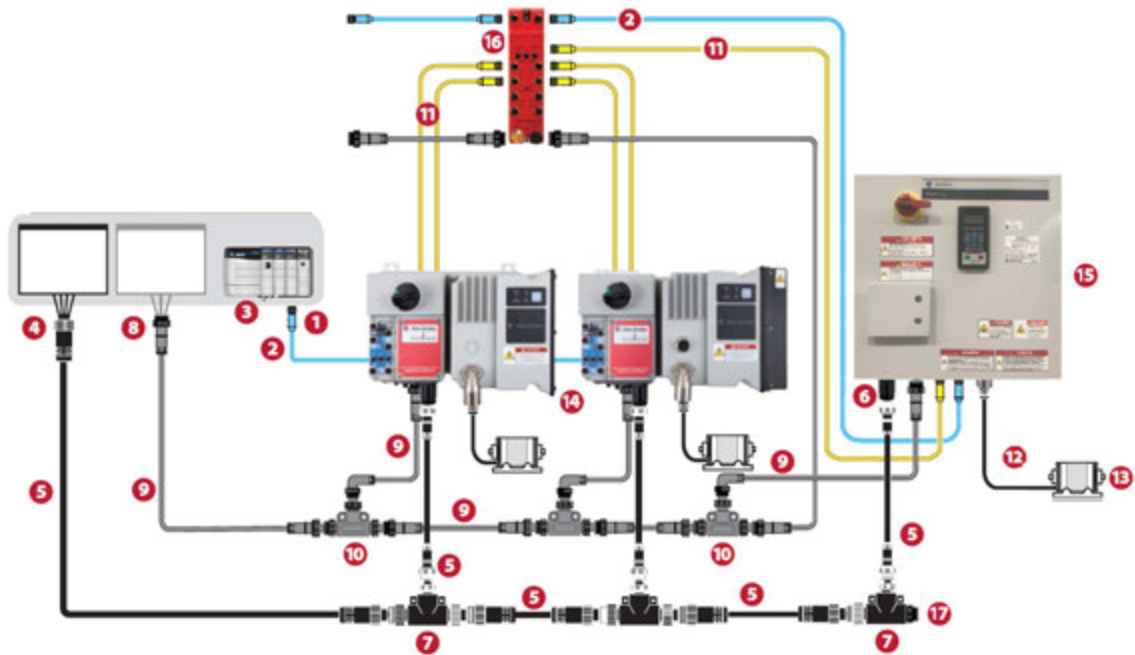

No.	Example Cat. No. ⁽¹⁾	Description
1	1585A-*	CAT5e Bulkhead Connector and Receptacle
2	1585D-*	CAT5e Patchcord, IP67, M12 D-Code
3	1585J-*	CAT5e, Patch Cable, IP20, RJ45 to RJ45
4	280-M35F-*	Three-Phase Power Receptacles - Female receptacles are a panel mount connector with flying leads
5	280-PWR35*	Three-Phase Power Trunk-Patchcord cable with integral female or male connector on each end
6	280-M35M*	Three-Phase Power Receptacles - Male receptacles are a panel mount connector with flying leads
7	280-T35	Three-Phase Power Tee connects to one M35 drop-line to trunk connectors
8	888N-*	Control Power Receptacles - Female/male receptacles are a panel mount connector with flying leads
9	889N-F4*	Control/Auxiliary Power Media Patchcords – Patchcord cable with integral female or male connector on each end
10	898N-43PB-N4KT	Control/Auxiliary Power Tees - The Tee is used with patchcord to connect several modified ArmorStart to the same control power source
11	889D-*	Patch cable between Safety I/O module output and the drive safety input, when hardwired based safety is used
12	2090-CPBM7E7*	SpeedTEC Cable, Motor Power With Brake Wires, SpeedTEC DIN Connector, Extension Receptacle (SpeedTEC ready) (only for servo motors)
	280-PWRM35* or 280-PWRM29*	Three-Phase power patchcord cable with integral female or male connector on each end (only for induction motors)
13	—	Induction motor or Allen-Bradley® servo motor
14	—	ArmorStart controller
15	—	PowerFlex 755 On-Machine Drive
16	1732ES-IB8X0BV4 or 1732ES-IB12X0BV2	ArmorBlock® Guard I/O™
17	889A-QCAP	Sealing cap, internal thread

(1) The (*) used in the example catalog number, represents the variations.

ArmorConnect Power Media

The ArmorConnect® power media offers both three-phase and control power cable systems. These include patchcords, receptacles, tees, reducers, and accessories to be used with the drive. These cable system components create a quick connection to the drive, reducing installation time. They provide for repeatable, consistent connection of the three-phase and control power to the drive and motor by providing a plug and play environment that also avoids system mis-wiring.

Details of ArmorConnect power media are described in the ArmorConnect Power and Control Media Selection Guide, publication [280PWR-SG001](#).

To specify power media for use with the drive, use only motor and power cables that are listed for use with the drive. See [Select Cables on page 38](#).



SHOCK HAZARD: Risk of electrical shock. Do not disconnect or connect power cables under load.



ATTENTION: ArmorConnect cables are not intended to be connected or disconnected under load. Physical injury or equipment damage will result from the high make and break currents, and potential fault currents.

Catalog Number Explanation

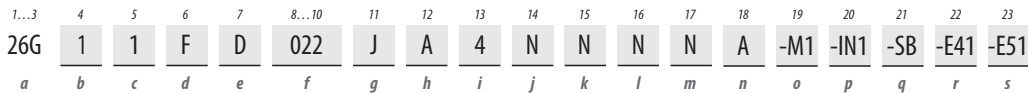

Drive	
Code	Type
26G	PowerFlex 755

Future Use	
Code	Description
1	Future Use

Input Type	
Code	Description
1	AC input with precharge, includes DC terminals

Enclosure Type	
Code	Type
F	UL Type 12 / IP66 (indoor use only)

Voltage Rating Class	
Code	Type
C	400V AC, 50 Hz
D	480V AC, 60 Hz

Normal Duty Drive Rating @ 400V AC, 50 Hz			
Code	Amps	kW	Frame
8P7	8.7	4	2
011	11.5	5.5	2
015	15.4	7.5	2
022	22.0	11	2

Normal Duty Drive Rating @ 480V AC, 60 Hz			
Code	Amps	Hp	Frame
8P0	8.0	5	2
011	11.0	7.5	2
014	14.0	10	2
022 ⁽¹⁾	22.0 / 14.0	15 / 10	2

(1) Option 022 for 22A, 15Hp, Normal Duty with induction motor or Allen-Bradley® servo motor. Option 022 for 14A, 10Hp, Heavy Duty with Allen-Bradley servo motor only.

Filtering and Common Mode Cap Configuration		
Code	Filtering	Default Connection
J	Yes	Jumper installed

Dynamic Braking (internal to drive)		
Code	Resistor	Transistor
A	No	Yes

Cover Mounted HIM	
Code	Type
4	UL Type 4x / IP66

Future Use	
Code	Description
N	Future Use

Safety Option Module - Slot 6	
Code	Type
A	Network Integrated Safe Torque Off Module (STO) S3
B ⁽¹⁾⁽²⁾⁽³⁾	Network Integrated Safety Function (SSM) S4
C ⁽¹⁾⁽²⁾⁽⁴⁾	Network Integrated Safety Function with Brake Control (S4)
N	None

- (1) Integrated Safety Function option module requires Studio 5000 V31.00 or higher firmware with Guard Logix 5580 or Compact GuardLogix 5380 controllers for drive safety functions.
- (2) Options B and C require, at a minimum, selection of one of the following options: E42, E43, E44, E51, E52, E53, E55, E56.
- (3) Option B provides two customer safety inputs, S0 and S1.
- (4) Option C uses the safety output S0 to provide control power to the brake circuit and provides one customer input S1. The S0 input is used internally to monitor the status of the brake contactor.

Motor Type	
Code	Motor
M1	Induction motor
M2 ⁽¹⁾⁽²⁾	Allen-Bradley MPL, MPM servo motor, for use with 14 AWG or 16 AWG motor cable
M3 ⁽²⁾⁽³⁾	Allen-Bradley MPL, MPM servo motor, for use with 10 AWG motor cable

- (1) Option M2 selected with Drive Rating 022 configures the drive for Heavy Duty (HD) rating.
- (2) M2 and M3 are only available in 480V AC / 60 Hz.
- (3) Option M3 for use with Drive Rating 022 only.

Connector - AC Input Power and Control		
Code	Input Size / Type	Control Size / Type
IN1	M35 Allen-Bradley, 4-pin male	Mini, 4-pin, male
IN2	Future use	Mini, 4-pin, male

Brake Control Options	
Code	Brake Control ⁽¹⁾
SB	400/480V AC source brake, M24 output receptacle, 3-pin female. No additional connector for brake
B2	24V DC brake, M24 output receptacle, 3-pin female with 24V DC auxiliary power input, mini 4-pin, male
B3	24V DC brake + servo motor output, M40 or M23 output receptacle, 6-pin, female with 24V DC auxiliary power input, mini 4-pin male

- (1) Options SB and B2 are for use with AC induction motors. Option B3 is for use with Allen-Bradley MPM and MPL servo motors.

Encoder Type - Slot 4		
Code	Type ⁽¹⁾	Receptacle
E41	Incremental HTL, 12V DC	M23, Female, 12-Pin, 20° Coded
E42	Hiperface SC	M23, Female, 12-pin, 20° Coded
E43	SSI SC Rotary	M23, Female, 12-pin, 20° Coded
E44 ⁽²⁾	Dual Incremental HTL, 12V DC	M23 (qty. 2), Female, 12-pin, 20° Coded
N	None (Future Use)	None (Future Use)

- (1) Option E41 is for use with the AC induction motors only. Option E42, E43, and E44 are for use with the AC induction and Allen-Bradley servo-motors.
- (2) Option E44 on-board P3 jumper is set to provide feedback to an SSM Safety Option Module.

Encoder Type - Slot 5		
Code	Type ⁽¹⁾	Receptacle
E51	Hiperface SC	M23, Female, 12-pin, 20° Coded
E52	Hiperface SC	AB servo motor bulk head
E53	Hiperface SC + SSI Linear	M23 (qty. 2), Female, 12-pin, 20° Coded
E54	SSI Linear	M23, Female, 12-pin, 20° Coded
E55	Hiperface SC + SSI Linear	AB servo motor bulk head + M23, Female, 12-pin, 20° Coded
E56	SSI SC Rotary	M23, Female, 12-pin, 20° Coded
N	None	None

- (1) Option E51, E53, E54, and E 56 are for use with AC induction motors. Option E52 and E55 are for use with Allen-Bradley servo motors.

Prepare for Installation

Topic	Page
Precautions	17
Environment	20
Wiring and Workmanship Guidelines	20
Electromagnetic Compatibility (EMC)	21
Power Requirements	22
Circuit Protection	23
Minimum Mounting Clearances	26
Dimensions	27
Receive, Unpack, and Inspect the Drive	28
Lift and Transport the Drive	31
Apply Labels to the Drive	34

Precautions



ATTENTION: This manual is intended for qualified service personnel responsible for installing and servicing these devices. You must have previous experience with, and a basic understanding of: electrical terminology, configuration procedures, required equipment, and safety precautions.



ATTENTION: The National Electrical Code (NEC), NFPA79, and any other governing regional or local code overrides the information in this manual. Rockwell Automation cannot assume responsibility for the compliance or proper installation of the On-Machine™ Drive. A hazard of personal injury and/or equipment damage exists if codes are ignored during installation.



ATTENTION: To avoid electrical shock, open the appropriate upstream protection (disconnect switch or branch circuit protection) before connecting and disconnecting cables. To avoid an electric shock hazard, verify that the voltage on the bus capacitors has entirely discharged before servicing.



ATTENTION:

- Installation, adjustments, putting into service, use, assembly, disassembly, and maintenance shall be performed by suitably trained personnel in accordance with applicable code of practice. Failure to do so may lead to personal injury or death, property damage, or economic loss.
 - If this equipment is used in a manner that is not specified by the manufacturer, the protection that is provided by the equipment, may be impaired.
-



WARNING: Circumstances that can cause an explosion may exist, which may lead to personal injury or death, property damage, or economic loss.

- Tripping of the instantaneous-trip circuit breaker is an indication that a fault current has been interrupted. Current-carrying components of magnetic motor controller should be examined and replaced if damaged to reduce the risk of fire or electrical shock.
 - Incoming power requirements must be a delta-Wye solid ground neutral to maintain the CE/UL certification. If the user supplied input power distribution exceeds 20 times the drive rating kVa, additional impedance must be supplied in the form of an input line reactor or isolation transformer.
-



ATTENTION: Do not operate controls or open covers without appropriate personal protective equipment. Failure to comply will result in serious injury or death.



ATTENTION: The drive contains high-voltage capacitors that take time to discharge after removal of the main supply. Before working on the drive, isolate the main power supply from line inputs (L1, L2, L3). Wait 3 minutes for the capacitors to discharge to minimal voltage levels. Failure to do so may result in personal injury or death.

Electrical Safety Considerations

IMPORTANT To avoid electrolytic corrosion on the external earth terminal, avoid spraying moisture directly on the terminal. When used in wash-down environments, apply a sealant or other corrosion inhibitor on the external ground terminal to minimize any negative effects of galvanic or electro-chemical corrosion. Ground connections should be inspected regularly.

IMPORTANT To comply with the CE Low Voltage Directive (LVD), all connections to this equipment must be powered from a source compliant with the following:

- Safety extra low voltage (SELV) Supply
- Protected extra low voltage (PELV) Supply

To comply with UL/C-UL requirements, this equipment must be powered from a source compliant with the following:

- IEC 60950-1 Ed. 2.1, Clause 2.2 - SELV Circuits

Environment and Enclosure

IMPORTANT This equipment is supplied as enclosed equipment. It should not require an additional system enclosure when used in locations consistent with the enclosure type ratings stated in the [Environment on page 20](#) section of this publication. Subsequent sections of this publication may contain additional information regarding specific enclosure type ratings, beyond what this product provides, that are required to comply with certain product safety certifications.

In addition to this publication, see the following:

- See also the following: NEMA 250 and IEC 60529, as applicable, for explanations of the degrees of protection provided by enclosures.
-

IMPORTANT This equipment is not intended for use in residential environments and may not provide adequate protection to radio communication services in such environments.

IMPORTANT This equipment is intended for use in overvoltage Category III applications (as defined in IEC 60664-1), at altitudes up to 2000 m (6562 ft) at the default carrier frequency without derating. See PowerFlex® 755 On-Machine Drive Specifications, publication [750-TD003](#) for altitude and derating information.



At the End of Life, this equipment should be collected separately from any unsorted municipal waste.

Prevent Electrostatic Discharge



ATTENTION: This drive contains ESD (Electrostatic Discharge) sensitive parts and assemblies. Static control precautions are required when you install, test, service, or repair this assembly. Component damage can result if ESD control procedures are not followed. If you are not familiar with static control procedures, see an applicable ESD protection handbook.

Environment

Before deciding on an installation site, verify that the drives are not installed in an area where the ambient atmosphere contains volatile or corrosive gas, vapors, or dust. Install the drive according to the required environmental ratings only.

Specifications for the components in the drive are in their respective publications and package contents, which are listed in the [Additional Resources on page 8](#) table and in the [Crate Contents on page 29](#).

Table 1 - Environmental Conditions

Condition	Requirement
Ambient Operating Temperature	0 °C...+40 °C (32 °F...104 °F)
Storage Temperature	-20 °C...+70 °C (-4 °F...+158 °F)
Relative Humidity	5...95% (non-condensing)
Cabinet Rating ⁽¹⁾	UL Type 12 / IP66 (indoor use only)

(1) Enclosure provides protection from: dust, falling debris, and hose-directed water.

Wiring and Workmanship Guidelines

In addition to conduit and seal-tite raceway, it is acceptable to use cable that is rated Tray Cable Exposed Runs (TC-ER), for power and control wiring on drive installations. The National Electrical Code (NEC) and NFPA 79 outline the following guidance for installations in the United States and Canada. The electrical standard for industrial machinery states that, cable tray use and installation, the utilization of equipment or devices, equipment grounding, and conductor size must be implemented according to NFPA 79, NEC article 9, section 336.10.

While the drive is intended for installation in factory floor environments of industrial establishments, the following must be considered when locating the drive in the application:

- Cables that include control voltage cables, for example, 24V DC, safety, and communications, are not to be exposed to operator or building traffic on a continuous basis.
- Location of the drive to minimize exposure to continual traffic is recommended. If a location to minimize traffic flow is unavoidable, other barriers to minimize inadvertent exposure to the cabling must be considered.
- Cables must be routed to minimize inadvertent exposure and/or damage.
- If conduit or other raceways are not used, we recommend that strain relief fittings be used when installing the cables for the control and power wiring through the conduit openings.
- Three-phase power cabling must be kept at least 150 mm (6 in.) away from EtherNet/IP network cables to avoid noise issues. EtherNet/IP is an unpowered network. If the device status is important when the power distribution disconnect is in the OFF position, the CP receptacle (pin 2 + and pin 3 –) must have an unswitched power source.

Electromagnetic Compatibility (EMC)

The following guidelines are provided for EMC installation compliance.

General Notes

- The motor cable must be kept as short as possible to avoid electromagnetic emission and capacitive currents.
- Conformity of the drive with CE EMC requirements does not guarantee that an entire machine installation complies with CE EMC requirements. Many factors can influence total machine/installation compliance.
- Drives contain an EMI filter, so it must only be used in installations that are solidly grounded (bonded) to the building power distribution ground. Grounding must not rely on flexible cables and must exclude any form of plug or socket that would permit inadvertent disconnection. Some local codes can require redundant ground connections. The integrity of all connections must be periodically checked.

- When using a shielded motor cable, the drain wire must be bonded to chassis ground at the motor. The recommended motor connection must use a shielded concentric connector. This connection provides 360° shielding.

Wiring

Wire in an industrial control application can be divided into three groups: power, control, and signal. The following recommendations for physical separation between these groups, are provided to reduce the coupling effect:

- Minimum spacing between different wire groups in the same tray must be 16 cm (6 in.).
- Wire runs outside an enclosure must be run in conduit or have shielding/armor with equivalent attenuation.
- Different wire groups must be run in separate conduits.
- Minimum spacing between conduits that contain different wire groups must be 8 cm (3 in.).

Power Requirements

Consider the power requirement and the construction of the circuits and their connections to the system when planning the installation of the drive.



WARNING: Circumstances that can cause an explosion may exist, which may lead to personal injury or death, property damage, or economic loss. Incoming power requirements must be a delta-Wye solid ground neutral to maintain the CE/UL certification. If the user supplied input power distribution exceeds 20 times the drive rating kVa, additional impedance must be supplied in the form of an input line reactor or isolation transformer.

Table 2 - Power Requirements

Condition	Requirement
Short-circuit current rating	Maximum short circuit rating 65,000 A RMS symmetrical
Voltage and power ratings ⁽¹⁾	400V AC, 3 PH, 50 Hz ratings: <ul style="list-style-type: none"> • 8.7 A, 4 kW, Normal Duty • 11.5 A, 5.5 kW, Normal Duty • 15.4 A, 7.5 kW, Normal Duty • 22 A, 11 kW, Normal Duty 480V AC, 3 PH, 60 Hz, ratings: <ul style="list-style-type: none"> • 8 A, 5 Hp, Normal Duty • 11 A, 7.5 Hp, Normal Duty • 14 A, 10 Hp, Normal Duty • 22 A, 15 Hp, Normal Duty • 14 A, 10 Hp, Heavy Duty (only when Motor Type = M2)
Battery	Factory-installed CR1220 lithium coin cell battery provides power to the real-time clock (supplied). Preserves the clock setting in the event power to the drive is lost or cycled. Approximate life is 4.5 years with drive unpowered, or lifetime if drive is powered.

(1) All ratings to support continuous duty. There is no de-rate for duty cycle variations. All ratings are for normal duty except for the variation that has 14 A Heavy-Duty rating.



ATTENTION: The PowerFlex 755 drive contains protective Metal Oxide Varistors (MOVs) that are referenced to a ground. These devices must not be disconnected or installed on an ungrounded and high resistive distribution system. Failure to do so may lead to personal injury or death, property damage, or economic loss.

IMPORTANT The drive requires a solidly grounded delta-wye power source (for example, 480/277V AC or 400/230V AC, 3-phase power source). If applied to a grounded or ungrounded 400/480V AC delta power source, abnormal ground currents will be detected and cause the EMI filter to be damaged.

IMPORTANT The safety ground, PE, must be connected to earth-grounding-system. Some codes may require redundant ground paths and periodic examination of connection integrity.

Circuit Protection

Branch circuit protection for the drive is provided by the internal circuit breaker, which complies with UL508 and CSA guidelines.



WARNING: Circumstances that can cause an explosion may exist, which may lead to personal injury or death, property damage, or economic loss. If the branch circuit protection device trips, you must use the software to verify that the source brake function is still operational before putting the equipment back in service. If the source brake function is not working properly, loss of brake function or motor damage can occur.

The feeder available fault current must not exceed 65,000 A RMS symmetrical at 480V AC. Input feeder power fuse and/or circuit breaker protection is required for the M35 input connector and you must provide it based on NEC guidelines and specific local codes.

Refer to [Figure 2](#) for more information.

Figure 2 - Feeder Circuit Protection

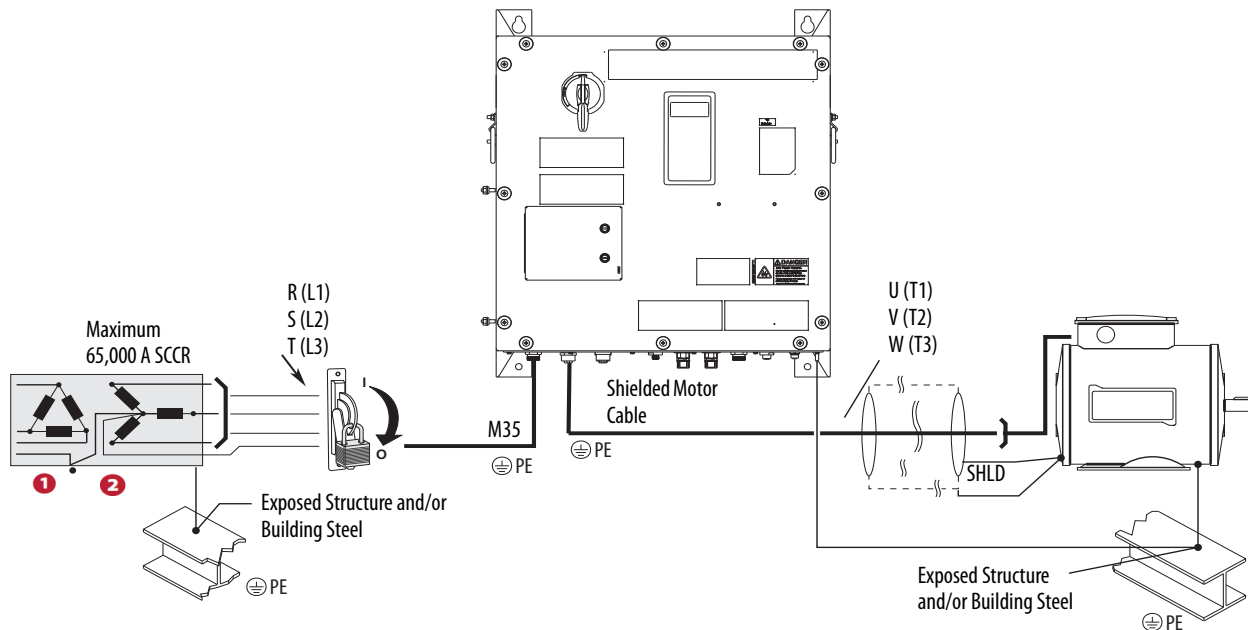

1. From user-supplied 400/480V AC, 3-phase, 50/60 Hz delta-Wye connected power distribution with solidly grounded neutral.
2. If the user-supplied input power distribution exceeds 20 times drive rating kVA, additional impedance must be supplied in the form of an input line reactor or isolation transformer.

Short-circuit current rating (SCCR)

The short-circuit rating for the drive is 65,000A RMS at 400/480V AC. The suitable circuit breaker for this circuit must be capable of delivering not more than 65,000 RMS symmetrical amperes at 480V AC, 100 A maximum, when protected by a Bulletin 140G-H frame circuit breaker. Also, the suitable fuses for this circuit must be capable of delivering not more than 65,000 RMS symmetrical amperes at 480V AC maximum when protected by CC, J, and T class.



WARNING: Circumstances that can cause an explosion may exist, which may lead to personal injury or death, property damage, or economic loss. Do not install the drive where the maximum available fault current exceeds the 65,000 A RMS symmetrical amperes.

Circuit Breakers

The drive has three circuit breakers that are accessible on the front cover. All three circuit breakers must be made with power present for the drive to operate and control the motor and brake properly. The 400/480V AC main input rotary circuit breaker provides power through the M35 power receptacle (L123). See [Feeder Circuit Protection on page 24](#) for more information.

The mechanical brake circuit breaker and the control power circuit breaker are located under the auxiliary circuit breaker door and are provided power by Receptacles CP (24V DC auxiliary power), CPBR (24V DC brake option B2 and B3), and L123 (source brake option SB). The brake circuit breaker will vary in design and operation depending on if it is a 24V DC mechanical brake or 400/480V source mechanical brake.



ATTENTION: Do not cycle 400/480V AC power more frequently than one cycle every 1 minute. Failure to comply will result in serious equipment damage.

A visual inspection can verify that the breakers are individually opened or closed. For information on how to open the auxiliary circuit breaker door and more details about the circuit breaker reset procedures, see [Reset Drive via the Circuit Breaker Switch on page 177](#) and [Open Auxiliary Circuit Breaker Door on page 176](#).

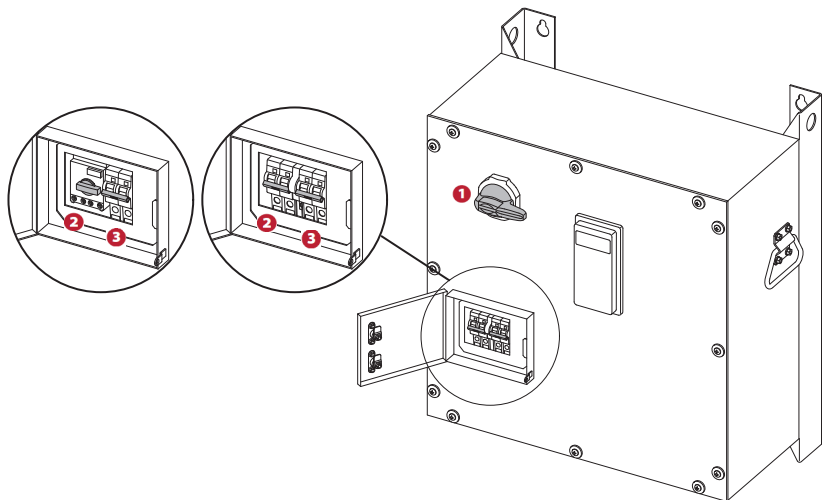

1. 400/480V AC rotary power for main circuit breaker (140G-G6C3-C30-AJ).
2. 24V DC mechanical brake circuit breaker (1489-M2D040) is shown on the enclosure.
The 400/480V AC source mechanical brake circuit breaker (140M-C2E-B25) is shown on the left.
3. 24V DC control power circuit breaker (1489-M2D2040).

Branch Circuit Protection Requirements for Three-Phase Power Media

The ArmorConnect® power media cables are rated per UL Type TC 600V 90 °C (194 °F) Dry 75 °C (167 °F) Wet, Exposed Run (ER), or MTW 600V 90 °C (194 °F) or STOOV 105 °C (221 °F) 600V - Canadian Standards Association (CSA) STOOV 600V FT2. For additional information regarding ArmorConnect power media see ArmorConnect Power and Control Media Selection Guide, publication [280PWR-SG001](#).

For rated ArmorConnect motor cable assemblies:

Circuit Breaker: Suitable for use on a circuit capable of delivering not more than 65,000 RMS symmetrical amperes at 480V AC maximum, when mostly protected by a catalog number 140G-H6C3-C60 circuit breaker with a maximum ampere rating of 60 A and an interrupting rating not less than of 65,000 RMS symmetrical amperes, 480V AC.

Fuses: Suitable for use on a circuit capable of delivering not more than 65,000 RMS symmetrical amperes at 480V AC maximum when mostly protected by Class CC, J, or T fuses, with a maximum ampere rating of 60 A.



ATTENTION: The total circuit impedance, including the impedance of each cable assembly, must be low enough to confirm that any short circuit or ground fault current that can flow through any assembly, is large enough to operate the magnetic trip of the circuit breaker. See your local electrical code for acceptable practices for this evaluation.

Minimum Mounting Clearances

Be sure that there is adequate clearance for air circulation around the drive. For best air movement, do not mount drives directly above each other.

Drives should be mounted with a minimum of 152.4 mm (6 in.) of clearance from the top, bottom, left, and right sides. Additional clearance may be needed on the bottom for connecting cables. There must be a minimum of 914.4 mm (36 in.) of clearance in front of the drive. No devices are to be mounted behind the drive. This area must be kept clear of all control and power wiring.

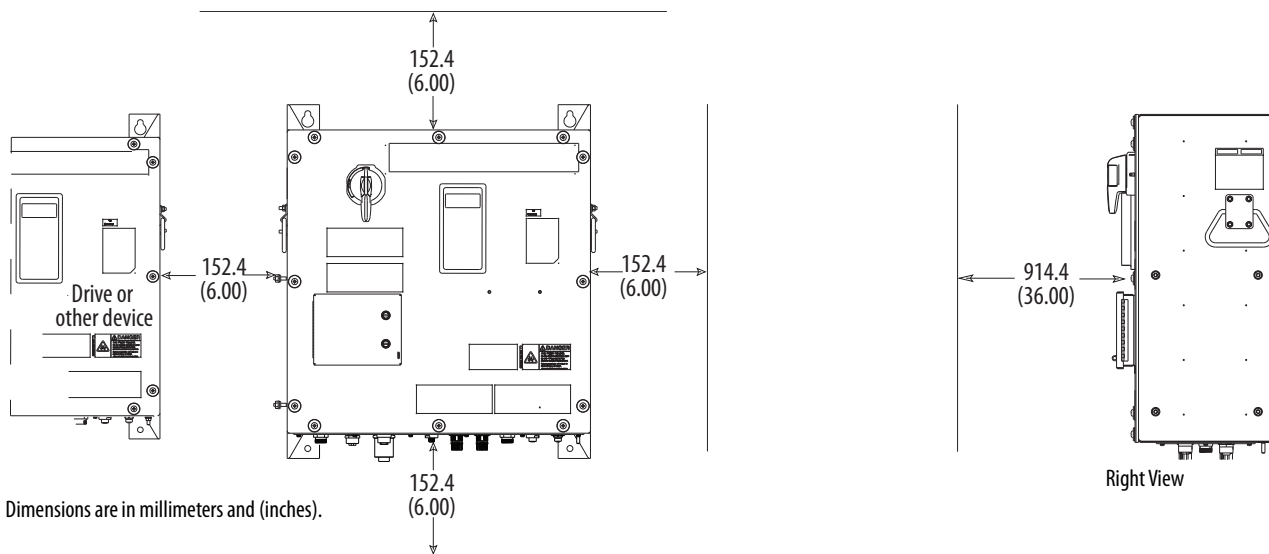

Dimensions

The approximate dimensions are shown in millimeters (inches). Dimensions are not intended to be used for installation purposes. All dimensions are approximate.

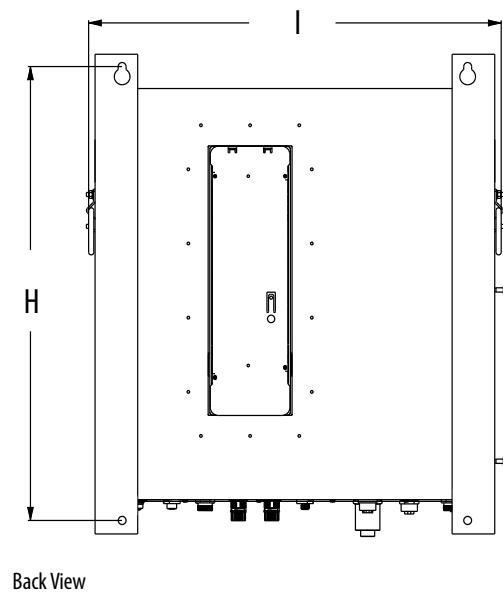
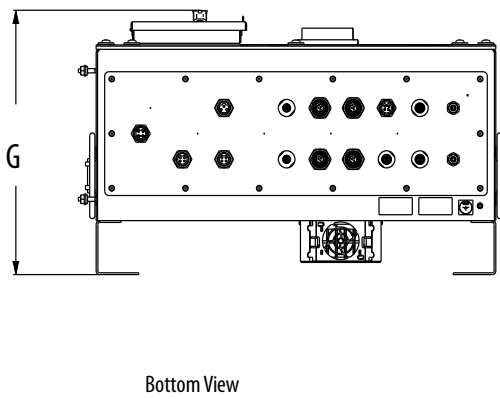
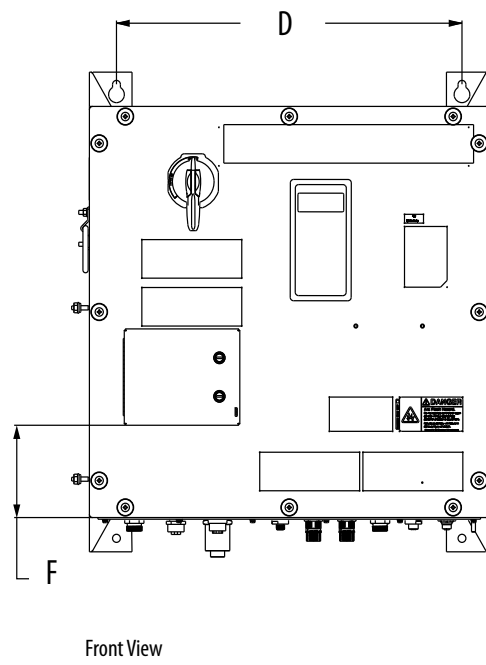
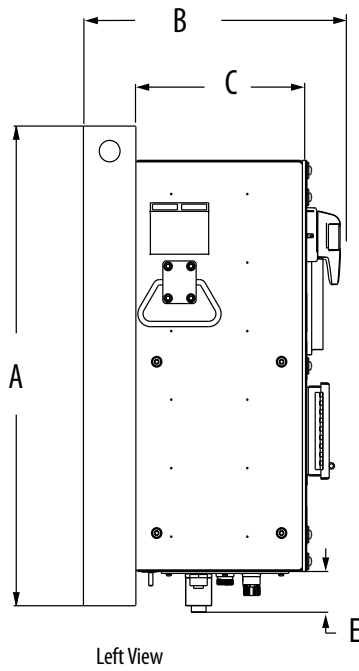

Drive Dimensions	A	B	C	D	E	F	G	H	I
Millimeters	711.2	391.9	260.5	527.0	52.88	136.9	391.9	673.0	649.8
Inches	28.0	15.3	10.26	20.75	2.08	5.39	15.43	26.5	25.58

Receive, Unpack, and Inspect the Drive

Upon delivery, follow these steps to unpack and inspect the drive. The carton label appears similar to the example below and contains basic product and packaging information.

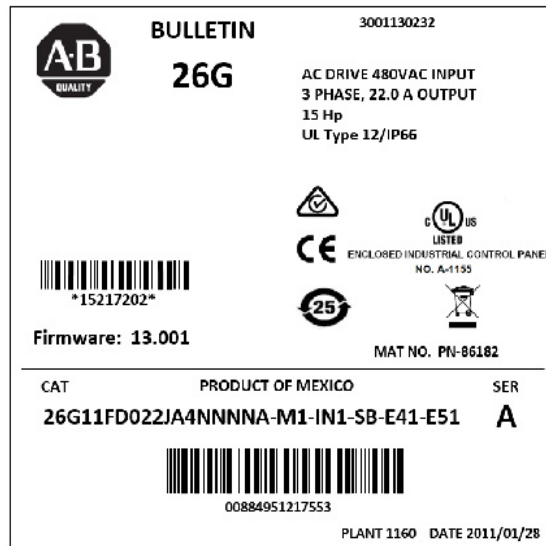

CARTON LABEL SAMPLE

Receiving

Standard drive enclosures are shipped horizontal. Each unit or shipping section is bolted to a wooden shipping skid with removable shipping cleats and is covered an anti-corrosion type of plastic wrap. Protection is for horizontal shipping and some water resistant protection, but it is not waterproof. For ease of handling, Rockwell Automation recommends leaving the enclosures bolted to the skids until moved to the final installation area.

Heavy duty/export packaging is similar to standard packaging, but uses wood framing for added structural support and a reactive barrier film safe for all materials providing permanent, humidity and temperature independent, volatile and oil free ESD protection combined with long-term corrosion protection and mold / mildew protection.

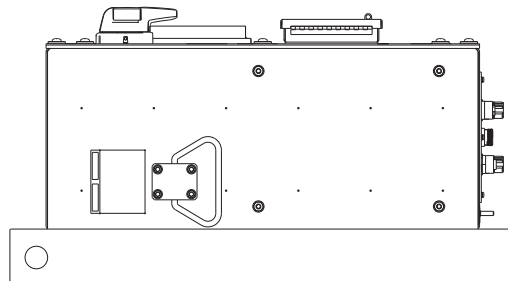

Upon delivery of the drive, refer to the packing slip for sizes and exact shipping weights. The packing slip will also list the items that are included in the shipment. Inspect the shipment for damaged or lost items.

Table 3 - Product Weight and Dimensions

Condition	Description (Approx)
Enclosure Dimensions (H x W x D)	609.6 mm x 609.6 mm x 274.4 mm (24 in. x 24 in. x 11 in.)
Product Dimensions (H x W x D)	711.2 mm x 649.8 mm x 391.9 mm (28 in. x 25.58 in. x 15.43 in.)
Packaging Dimensions (H X W x D) with product inside	475 mm x 800 mm x 800 mm (18.69 in. x 31.5 in. x 31.5 in.)
Weight	47.62 kg (approx. 105 lb)
Weight with packaging	63.95 kg (approx. 141 lb)

IMPORTANT For drives that were in storage and did not have voltage applied, maintenance of the capacitors in the drive may be required. For drives that are stored under 2 years, there is no additional maintenance required. For storage greater than 2 years, see Preventive Maintenance Checklist of Industrial Control and Drive System Equipment, publication [DRIVES-TD001](#) for bus capacitor reforming requirements or [Table 9 on page 200](#).

Crate Contents

The following is a list of items that are included in the crate:

- On-Machine Drive
- Electrical schematics specific to shipped unit
- Language labels
- Product Information, publication [750-PC004](#)
- An envelope containing installation instructions for components

TIP To order additional copies of the electrical schematics, contact your local Allen-Bradley distributor or Rockwell Automation sales representative.

Unpack and Inspect

If the packaging appears to be damaged, take photos of the damaged shipment with the packaging then unpack the equipment for further inspection. Open the cover and inspect the major components for signs of damage. Retain the original packaging for the freight inspector.

IMPORTANT Delivery of equipment from Rockwell Automation to the carrier is considered delivery to the buyer. The carrier becomes liable for any damage that occurs during transit. It is the responsibility of the buyer to notify the proper party if damage is found. The buyer can forfeit any right to recovery for loss or damage by failing to comply with these steps.

1. Inspect the shipping container for any damage that occurred during transit.
2. Remove the cover of the shipping container.
3. Remove the sides of the shipping container.
4. Remove the protective packing materials.
5. Inspect the drive for any damage.
6. If enclosure appears damaged, open the front cover and inspect the major components for damage. See [Remove the Front Cover on page 148](#) for instructions on how to open the front cover.

IMPORTANT Only open the front cover of the enclosure if you suspect the components inside are damaged.

7. If damage to the enclosure exists:
 - a. Note on the delivery receipt that the equipment is damaged.
 - b. Contact the carrier that delivered the shipment and the authorized Allen-Bradley® distributor. The carrier may schedule a freight inspection or will waive their right to inspect. If they waive their right to inspect, obtain the written waiver.
 - c. Retain all product packaging for review by the carrier.

Lift and Transport the Drive

All lifting equipment and components (hooks, bolts, lifts, slings, chains, and so on) must be properly sized and rated to lift and hold the weight of the drive. Read these precautions before attempting to lift a drive.



ATTENTION: All equipment and hardware that is used to lift the drive must be properly sized and rated to lift and hold the weight of the drive safely. To guard against possible personal injury or equipment damage:

- Inspect all hardware for proper attachment before a drive is lifted.
 - Do not allow any part of the drive or lift equipment to contact electrically charged conductors or components.
 - Do not allow personnel or their limbs directly beneath the drive during a lift.
-



ATTENTION: To guard against death, serious personal injury, or equipment damage, do not subject the drive to high rates of acceleration or deceleration while lifting or transporting.

Follow these steps to lift a drive to an upright position.

1. Optionally, for easier access to the drive, remove the T25 hexalobular screws that secure the sides of the shipping container, and remove the container sides.
2. Insert and secure the appropriate hardware in the designated lifting holes (as shown in the illustration).



ATTENTION: To guard against equipment damage, verify that the hardware is securely connected to the correct lifting holes in the drive as shown.

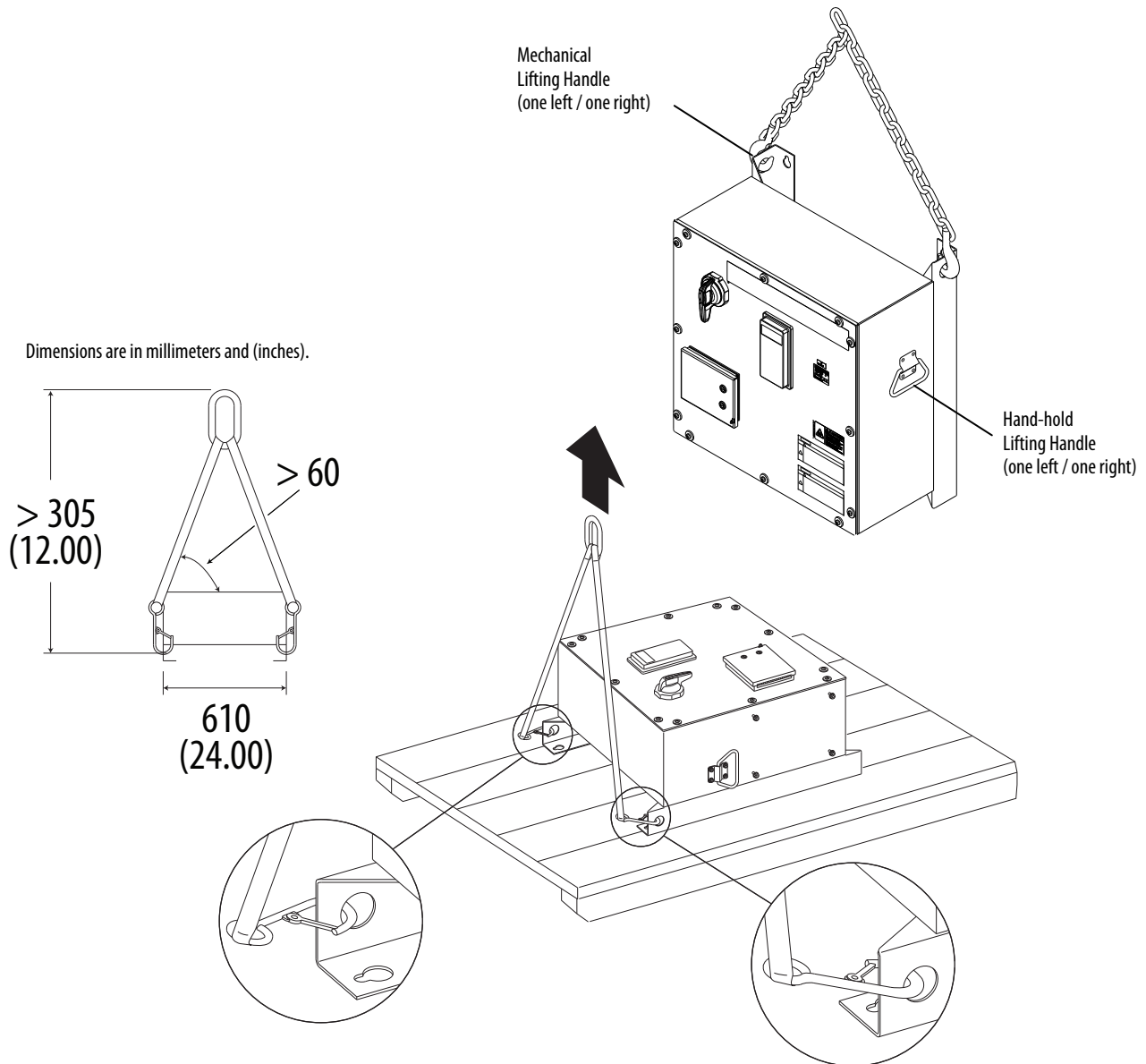

3. To reduce tension on the rigging and compression on the structural angle, verify that the angle between the straps or cables and horizontal plane is greater than 60°.



ATTENTION: When approaching the full upright (vertical) position, the weight can shift and cause the drive to swing unexpectedly. Control the movement of the drive as it is lifted from the shipping container. Failure to comply can result in personal injury or equipment damage.

4. Slowly lift the drive from the shipping container and transport the drive to the installation location.



ATTENTION: Risk of equipment damage exists. Interconnect receptacles protrude from the bottom of the drive. Be sure that the drive does not crush or apply pressure to the receptacles when placed on a flat surface or installed.

Do not remove the hardware that is used to lift the drive until the drive has been secured and stabilized.

Two-Person Lifting

The drive weighs more than 45.36 kg (100 lb). As a result, two people are required to hand-lift the drive.



ATTENTION: Hazard of personal injury and machine damage exists. Do not attach lifting straps to the handles.

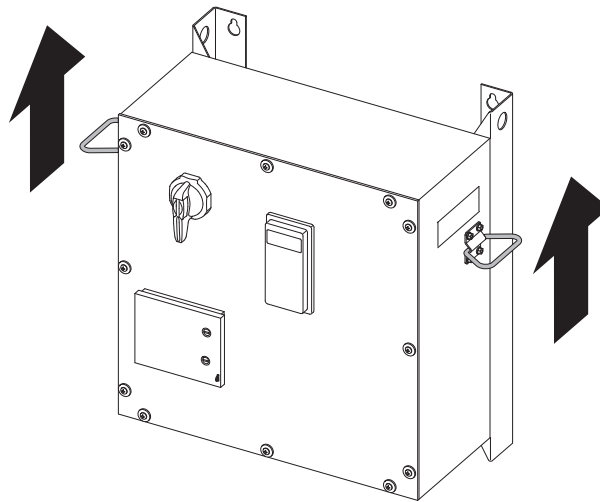

Apply Labels to the Drive

The multiple language labels for the product are shipped with the product and must be attached to the drive. The English and French language labels should not be removed or covered up. Any additional labels must be added on a bare surface.

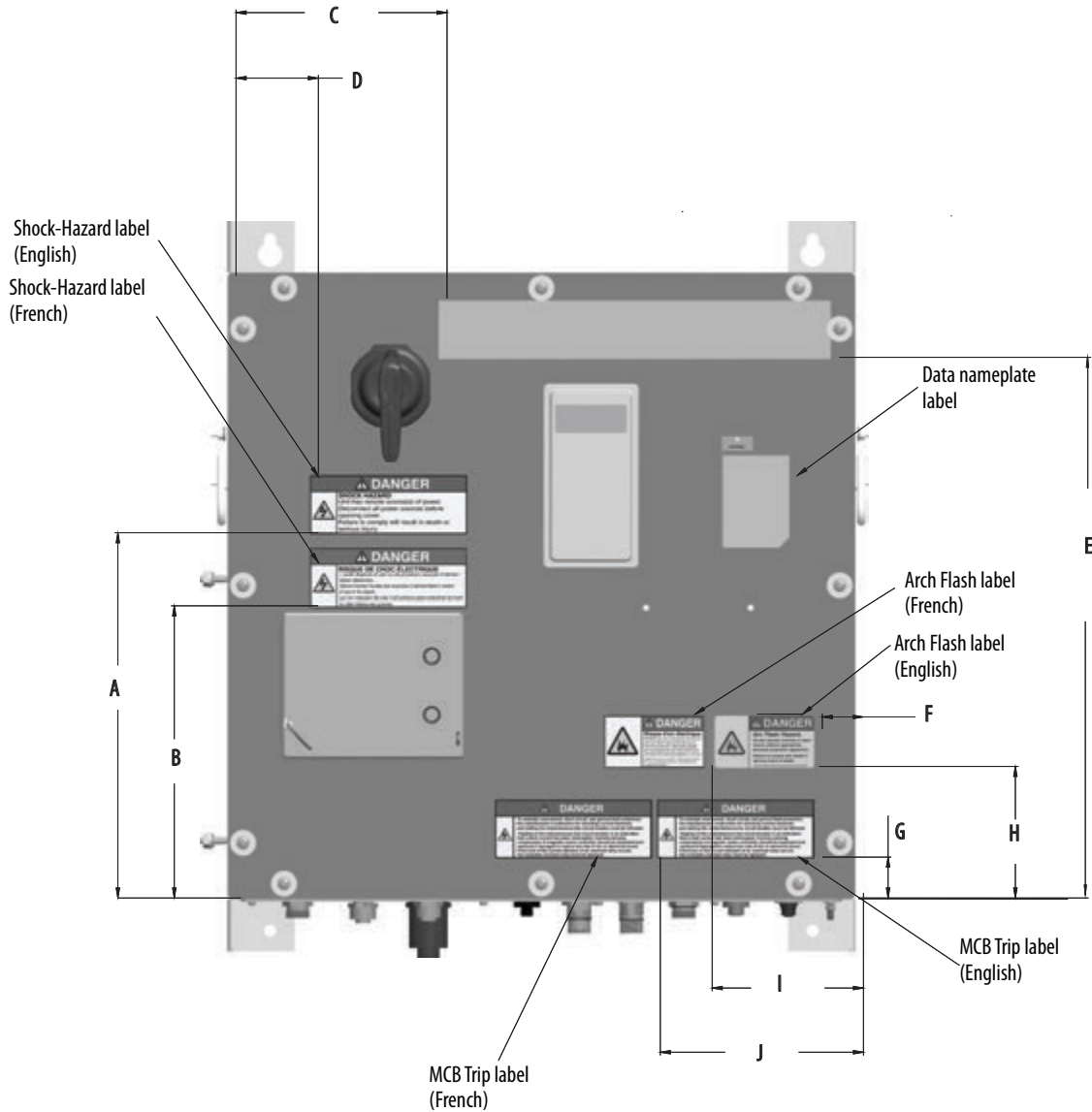

Drive Label Dimensions	A	B	C	D	E	F	G	H	I	J
Millimeter	355.0	284.0	205.0	80.0	525.5	40.0	38.7	127.9	147.0	197.4
Inch	13.97	11.18	8.07	3.15	20.69	1.57	1.56	5.03	5.79	7.77

Install the Drive

Topic	Page
Mount the Drive	35
Ground the Drive	36
Shield and Ground Motors and Motor Cables	38
Select Cables	38
Control Power	44
Make Connections	44



ATTENTION: The following information is merely a guide for proper installation. Rockwell Automation cannot assume responsibility for the compliance or the noncompliance to any code, national, local, or otherwise for the proper installation of this drive or associated equipment. A hazard of personal injury and/or equipment damage exists if codes are ignored during installation.

Mount the Drive

All connections needed to set up the drive, including the EtherNet/IP network connection, are made without removing the front cover. The cover does not need to be removed to bring a drive into service.

For more information on requirements, see the warning and attention statements under [Prepare for Installation on page 17](#).

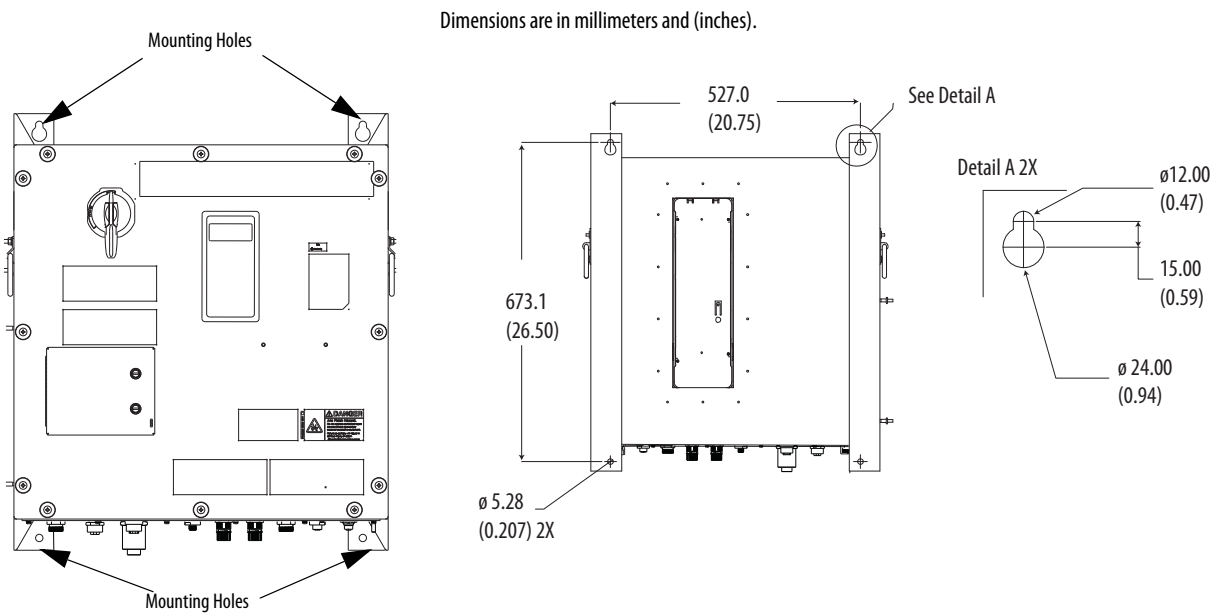

IMPORTANT Mounting environments vary. Verify that the fastening hardware type and torque values are rated for the weight of the enclosure and are suitable for the mounting environment.

Ground the Drive



ATTENTION: A hazard of personal injury and equipment damage exists. A minimum of 10 AWG should be used for the solid earth-grounding-system.

To properly ground the package drive, connect the Safety Ground-PE terminal to the power-distribution earth-grounding-system through a ground or low impedance connections. The ground connection must have sufficient current-carrying capacity to help prevent the build-up of voltages that can result in a hazard to the connected equipment or a person (as defined by the US National Electric Code NFPA70, Article 100B). Grounding is done for two basic reasons: safety (defined above) and noise containment or reduction. While the safety ground scheme and the noise current return circuit can sometimes share a path and components, they must be considered different circuits with different requirements.

See [Figure 1 on page 12](#) for the location of the PE Ground Stud.

See [Figure 2 on page 24](#) for an example of proper grounding.

IMPORTANT Grounding and power jumper configuration must be appropriate for EMC applications. See Drive Power Jumper Configuration in the PowerFlex® 750-Series AC Drives Installation Instructions, publication [750-IN001](#) for details. The On-Machine™ Drive is configured for EMC applications.

IMPORTANT The On-Machine Drive has multiple grounding locations. Refer to the electrical schematics for specific information about the grounding for your specific configuration. See the [Catalog Number Explanation on page 16](#) for more information about configuration type.

The drive has an internal ground bus to connect all incoming and outgoing connector grounds. The drive also has an external ground stud on bottom-right corner of enclosure to connect the PE ground stud with the earth-grounding-system.

Grounding Safety Grounds

The object of a safety ground is to verify that all metal work is at the same power-distribution earth-grounding-system potential, at power frequencies. Impedance between the drive and the building scheme ground must conform to the requirements of national and local industrial safety regulations or electrical codes. These requirements vary based on country, type of distribution system, and other factors. Periodically check the integrity of all ground connections.

General safety dictates that all metal parts are connected to the power-distribution earth-grounding-system with separate copper wire or wires of the appropriate gauge. Most equipment has specific provisions to connect a safety ground or PE (protective earth) directly to it.

IMPORTANT The safety ground (PE), must be connected to the power-distribution earth-grounding-system. Some codes may require redundant ground paths and periodic examination of connection integrity.

Grounding PE or Ground

The safety ground or PE, must be connected to the power-distribution earth-grounding-system. This ground point must be connected to adjacent building steel (girder, joist), a floor ground rod, busbar, or building ground grid. Grounding points must comply with national and local industrial safety regulations or electrical codes. Some codes can require redundant ground paths and periodic examination of connection integrity.

IMPORTANT To avoid electrolytic corrosion on the external earth terminal, avoid spraying moisture directly on the terminal. When used in wash-down environments apply a sealant or other corrosion inhibitor on the external ground terminal to minimize any negative effects of galvanic or electro-chemical corrosion. Ground connections must be inspected regularly.

Shield and Ground Motors and Motor Cables

The motor frame or stator core must be connected directly to the PE connection with a separate ground conductor. We recommend that each motor frame is grounded to building steel at the motor.

Refer to [Table 4 on page 39](#) for motor cable information.

Keep the motor cable lengths less than 13.7 m (45 ft) unless otherwise noted in the device specifications.



ATTENTION: Shielded motor cable is mandatory for CE-compliant installations. Failure to comply will result in equipment damage.

IMPORTANT For compatibility, the motor cable connector that is selected must provide good 360° contact and low transfer impedance from the shield or armor of the cable to the conduit entry plate at both the motor and the drive, for electrical bonding.

The motor cable should be kept as short as possible to avoid electromagnetic emissions and capacitive currents. CE conformity of drive with EMC Directive does not confirm that the entire machine installation complies with CE EMC requirements.

See the National Electrical Code (NEC) NFPA 70 and/or the Electrical Standard for Industrial Machinery NFPA 79 for proper installation details.

Select Cables

You are responsible for selecting and acquiring the required cables to connect the drive to the system configuration. This section contains a list of recommended cable types, cord sets, and patchcords. Before you begin, check to make sure that you have all components that you need to incorporate the drive into your network.

See the [Spare Parts Directory on page 203](#) for information on replacement interface receptacles.

See <https://ab.rockwellautomation.com/Connection-Devices/EtherNet-Media> and choose Ethernet Network Media for more information on Industrial Ethernet Media.

IMPORTANT Many of the receptacles could appear to be interchangeable because they have the same mounting hole pattern. Verify your pin out and connectors before attaching to the drive. Review the electrical schematics and receptacle abbreviations.

The receptacle groups that follow have similar mounting hole patterns but, they are not interchangeable:

- Encoder CFBM and Power Receptacle CPBM for ≤ 14 amps
- M23 Encoders: ENCO, HIPSC, SSIL, DENC0, DENC1, and SSISC
- Power Receptacles: L123, T123, DBR, and EMB1
- Control Power Receptacles: CP, CPBR, and EMB2
- Safety Receptacles: S0 and S1
- Control Receptacles: P0, P1, and DBRT

This table shows the corresponding cables needed to make the connections.

Table 4 - Cable Descriptions and Receptacle Information





Receptacle Abbreviation	Receptacle Description	Recommended Interface Cable / Connector ⁽²⁾	Cable Description	Image ⁽⁴⁾
L123	Input Power Receptacle, IN1, M35, 4-pin	280-PWRM35A-M*	ArmorConnect Power Media - Trunk Cable, IP67, UL 4/12, NEMA 6P, Straight Female to Straight Male Patchcord, 10 AWG	
		280-PWRM35E-M*	ArmorConnect Power Media - Trunk Cable, IP67, UL 4/12, NEMA 6P, Straight Female Cordset, 10 AWG	
T123 (for drive rating < 22 A)	Output Power Receptacle, M29, 4-pin	284-PWRM29A-M*	Shielded Motor patch cable assembly With straight Male/Female receptacle with leads, 29 mm Shell, 4-pin, 12 AWG	
		280-PWRM29A-M*	Non-Shielded Motor patch cable assembly With straight Male/Female receptacle with leads, 29 mm Shell, 4-pin, 12 AWG	
DBR (for drive rating < 22 A)	Dynamic Brake Receptacle, M29, 4-pin	284-PWRM29A-M*	Shielded Motor patch cable assembly With straight Male/Female receptacle with leads, 29 mm Shell, 4-pin, 12 AWG	
		280-PWRM29A-M*	Non-Shielded Motor patch cable assembly With straight Male/Female receptacle with leads, 29 mm Shell, 4-pin, 12 AWG	

Table 4 - Cable Descriptions and Receptacle Information (continued)













Receptacle Abbreviation	Receptacle Description	Recommended Interface Cable / Connector ⁽²⁾	Cable Description	Image ⁽⁴⁾	
T123 (for drive rating =22 A)	Output Power Receptacle, M35, 4-pin	280-PWRM35G-M ⁽³⁾	ArmorConnect Power Media - Trunk Cable, IP67, UL 4/12, NEMA 6P, Straight Male Cordset.		
		280-PWRM35A-M ⁽³⁾	ArmorConnect Power Media - Trunk Cable, IP67, UL 4/12, NEMA 6P, Straight Male to Straight Female Patchcord		
DBR (for drive rating = 22 A)	Dynamic Brake Receptacle, M35, 4-pin	280-PWRM35G-M*	ArmorConnect Power Media - Trunk Cable, IP67, UL 4/12, NEMA 6P, Straight Male Cordset.		
		280-PWRM35A-M*	ArmorConnect Power Media - Trunk Cable, IP67, UL 4/12, NEMA 6P, Straight Male to Straight Female Patchcord		
EMB1 or EMB2	Mechanical Brake Receptacle, M24, 3-pin	285-BRC22-M*D	Non-shielded patch cable assembly with straight male / straight female receptacle with leads, 22 mm shell, 3-pin, 16 AWG Conductors		
		285-BRC22D-M*	Non-shielded patch cable assembly with Straight Male receptacle with flying leads, 22 mm shell, 3-pin, 16 AWG Conductors		
CP	24V DC Control Power Receptacle, mini, 4-pin	889N-F4AFNM-*	Patchcord: Mini/Mini Plus, Female, Straight, 4-Pin, PVC Cable, Yellow, Unshielded, IEC Color Coded, Mini, Male, Straight, 16 AWG		
		889N-F4AENM-D*	22 mm, 18 AWG, 300V, 10 A, 4-pin, straight mini Male to straight Mini Female		
CPBR	24V DC Brake Power Receptacle, mini, 4-pin	889N-F4AFNM-*	Patchcord: Mini/Mini Plus, Female, Straight, 4-Pin, PVC Cable, Yellow, Unshielded, IEC Color Coded, Mini, Male, Straight, 16 AWG		
		889N-F4AENM-D*	22 mm, 18 AWG, 300V, 10 A, 4-pin, straight mini Male to straight Mini Female		
P0	P0 Digital Input Receptacle, micro, 5-pin	889D-F4ACDM-*	Patchcord: DC Micro (M12), Female, Straight, 4-Pin, PVC Cable, Yellow, Unshielded, IEC Color Coded, DC Mic, Male, Straight		
		879D-F4ACDM-*	V-Cable, DC Micro (M12), Female, Straight, 4-Pin, PVC Cable, Yellow, Unshielded, 22 AWG, DC Micro (M12), Straight Male		
		879D-R4ACDM-*	V-Cable, DC Micro (M12), Female, Right Angle, 4-Pin, PVC Cable, Yellow, Unshielded, 22 AWG, DC Micro (M12), Straight Male		
		889D-M4AC-*	DC micro (M12), Male, Straight, 4-Pin, PVC Cable, Yellow, Unshielded, IEC Color coded, No Connector		

Table 4 - Cable Descriptions and Receptacle Information (continued)







Receptacle Abbreviation	Receptacle Description	Recommended Interface Cable / Connector ⁽²⁾	Cable Description	Image ⁽⁴⁾
P1	P1 Digital Input Receptacle, micro, 5-pin	889D-F4ACDM-*	Patchcord: DC Micro (M12), Female, Straight, 4-Pin, PVC Cable, Yellow, Unshielded, IEC Color Coded, DC Mic, Male, Straight	
		879D-F4ACDM-*	V-Cable, DC Micro (M12), Female, Straight, 4-Pin, PVC Cable, Yellow, Unshielded, 22 AWG, DC Micro (M12), Straight Male	
		879D-R4ACDM-*	V-Cable, DC Micro (M12), Female, Right Angle, 4-Pin, PVC Cable, Yellow, Unshielded, 22 AWG, DC Micro (M12), Straight Male	
		889D-M4AC-*	DC Micro (M12), Male, Straight, 4-Pin, PVC Cable, Yellow, Unshielded, IEC Color Coded, No Connector	
DBRT	Brake Resistor Thermostat Temperature Receptacle, micro, 4-pin	889D-F4ACDM-*	Patchcord: DC Micro (M12), Female, Straight, 4-Pin, PVC Cable, Yellow, Unshielded, IEC Color Coded, DC Mic, Male, Straight	
		879D-F4ACDM-*	V-Cable, DC Micro (M12), Female, Straight, 4-Pin, PVC Cable, Yellow, Unshielded, 22 AWG, DC Micro (M12), Straight Male	
		879D-R4ACDM-*	V-Cable, DC Micro (M12), Female, Right Angle, 4-Pin, PVC Cable, Yellow, Unshielded, 22 AWG, DC Micro (M12), Straight Male	
		889D-M4AC-*	DC Micro (M12), Male, Straight, 4-Pin, PVC Cable, Yellow, Unshielded, IEC Color Coded, No Connector	
S0 (S3 safety)	S0 Safety Receptacle, micro, 5-pin	889D-F4ACDM-*	Patchcord: DC Micro (M12), Female, Straight, 4-Pin, PVC Cable, Yellow, Unshielded, IEC Color Coded, DC Mic, Male, Straight	
		879D-F4ACDM-*	V-Cable, DC Micro (M12), Female, Straight, 4-Pin, PVC Cable, Yellow, Unshielded, 22 AWG, DC Micro (M12), Straight Male	
		879D-R4ACDM-*	V-Cable, DC Micro (M12), Female, Right Angle, 4-Pin, PVC Cable, Yellow, Unshielded, 22 AWG, DC Micro (M12), Straight Male	
		889D-F4AC-*	DC Micro (M12), Female, Straight, 4-Pin, PVC Cable, Yellow, Unshielded, IEC Color Coded, No Connector	

Table 4 - Cable Descriptions and Receptacle Information (continued)

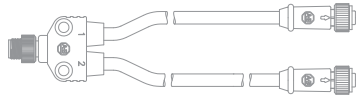
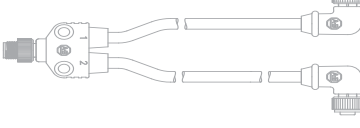

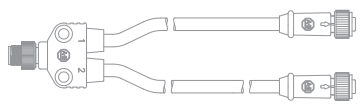
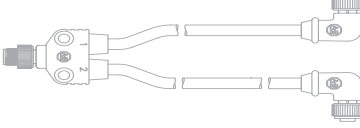

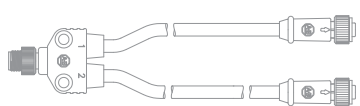
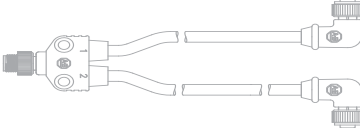







Receptacle Abbreviation	Receptacle Description	Recommended Interface Cable / Connector ⁽²⁾	Cable Description	Image ⁽⁴⁾
S0 (S4 safety)	S0 Network Safety Receptacle, A, micro, 5-pin	889D-M5AC-*	DC Micro (M12), Male, Straight, 5-Pin, PVC Cable, Yellow, Unshielded, IEC Color Coded, No Connector	
		889D-F5ACDM-*	Patchcord: DC Micro (M12), Female, Straight, 5-Pin, PVC Cable, Yellow, Unshielded, IEC Color Coded, DC Mic, Male, Straight	
		889D-F5ACDE-*	Patchcord: DC Micro (M12), Female, Straight, 5-Pin, PVC Cable, Yellow, Unshielded, IEC Color Coded, DC Mic, Male, R-Angle	
S0 (S4 safety with brake)	S0 Network Safety Receptacle, C, micro, 5-pin, female	889D-M5AC-*	DC Micro (M12), Female, Straight, 5-Pin, PVC Cable, Yellow, Unshielded, IEC Color Coded, No Connector	
		889D-F5ACDM-*	Patchcord: DC Micro (M12), Female, Straight, 5-Pin, PVC Cable, Yellow, Unshielded, IEC Color Coded, DC Mic, Male, Straight	
		889D-F5ACDE-*	Patchcord: DC Micro (M12), Female, Straight, 5-Pin, PVC Cable, Yellow, Unshielded, IEC Color Coded, DC Mic, Male, R-Angle	
S1 (S4 safety)	S1 Network Safety Receptacle, B&C, micro, 4-pin, female	889D-M5AC-*	DC Micro (M12), Male, Straight, 5-Pin, PVC Cable, Yellow, Unshielded, IEC Color Coded, No Connector	
		889D-F5ACDM-*	Patchcord: DC Micro (M12), Female, Straight, 5-Pin, PVC Cable, Yellow, Unshielded, IEC Color Coded, DC Mic, Male, Straight	
		889D-F5ACDE-*	Patchcord: DC Micro (M12), Female, Straight, 5-Pin, PVC Cable, Yellow, Unshielded, IEC Color Coded, DC Mic, Male, R-Angle	

Table 4 - Cable Descriptions and Receptacle Information (continued)

Receptacle Abbreviation	Receptacle Description	Recommended Interface Cable / Connector ⁽²⁾	Cable Description	Image ⁽⁴⁾
CFBM	HIP SC Encoder Receptacle, Servo, Bulk H, E52, E55	2090-CFBM7E7-CEAF**	SpeedTEC Cable, Motor Feedback Only, SpeedTEC DIN Connector, Extension Receptacle (SpeedTEC ready), SIN/COS High-Resolution/Resolver Encoder Type, Continuous-Flex	
CPBM (for drive rating = 22 A)	Output Power #10 and Brake, #18, Receptacle, 6-pin	2090-CPBM7E7-10AF**	SpeedTEC Cable, Motor Power With Brake Wires, SpeedTEC DIN Connector, Extension Receptacle (SpeedTEC ready), 10 AWG, Continuous-Flex	
CPBM (for drive rating < 22 A)	Output Power #14 and Brake, #18, Receptacle, 6-pin	2090-CPBM7E7-14AF**	SpeedTEC Cable, Motor Power With Brake Wires, SpeedTEC DIN Connector, Extension Receptacle (SpeedTEC ready), 14 AWG, Continuous-Flex	
ENCO ⁽¹⁾	Incremental Encoder Receptacle, M23, 12-pin, E41	N/A	N/A	N/A
HIPSC ⁽¹⁾	HIP Encoder Receptacle, M23, 12-pin, E42			
SSISC ⁽¹⁾	SSI SC Rotary Encoder Receptacle, M23, 12-pin, E43			
DENCO ⁽¹⁾	Dual Incremental Encoder Receptacle, M23, 12-pin, E44, female			
DENC1 ⁽¹⁾	Dual Incremental Encoder 1 Receptacle, M23, 12-pin, E44			
HIPSC ⁽¹⁾	HIP SC Encoder Receptacle, M23, 12-pin, E51, E53			
SSIL ⁽¹⁾	SSI Linear Encoder Receptacle, M23, 12-pin, E53, E54, E55			
SSISC ⁽¹⁾	SSI SC Rotary Encoder Receptacle, M23, 12-pin, E56			
ETH1 / ETH2 (Ethernet)	Micro D-Code, QD Style Ethernet Media	1585D-M4TBJM-*	1585 Ethernet Cables, 4 Conductors, M12, Straight Male, Standard, RJ45, Straight Male, Teal Robotic TPE, 100BASE-TX, 100 Mbit/s, 4 Conductor, Teal TPE, Flex Rated	
		1585D-M4TBDM-*	1585 Ethernet Cables, 4 Conductors, M12, Straight Male, Standard, M12, Straight Male, Teal Robotic TPE, 100BASE-TX, 100 Mbit/s, 4 Conductor, Teal TPE, Flex Rated	
		1585D-M4TB-*	1585 Ethernet Cables, 4 Conductors, M12, Straight Male, Standard, Flying Leads, Teal Robotic TPE, 100BASE-TX, 100 Mbit/s, 4 Conductor, Teal TPE, Flex Rated	

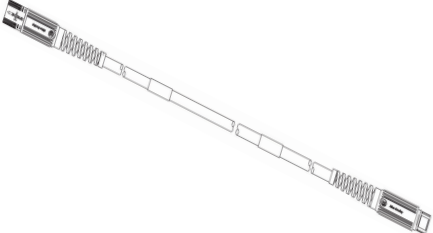
- (1) Use M23, 12-Pin, 20° coded connector cable. The cable jacket that is used, must be marked and tested for UL oil resistance, to preserve the UL Type 12 rating for the On-Machine Drive in the end user application. Always use shielded cable with copper wire. We recommend wire with an insulation rating of 300V or greater. Separate analog signal wires from power wires by at least 0.3 m (1 ft).
- (2) For recommended connectors/cables that contain an (*), the asterisk represents variance in cable lengths and configuration options.
- (3) Rockwell Automation only supplies unshielded motor cables for the M35 Motor Receptacles. Contact your local Rockwell Automation distributor directly for shielded motor cables.
- (4) The images that are used are examples only, and are not true representations of the connectors used.

Control Power

The drive uses 24V DC control power for communications and I/O. It uses switched power supplies for the outputs. Unswitched power supplies provide power to Logix and sensor inputs. For more information about the control power pin out information, see [Receptacle Connections on page 47](#).

24V DC Control Power Receptacle

- CP [output power (pin 1)] = Switched +V
- CP [sensor power (pin 2)] = Unswitched +V
- CP [sensor power (pin 3)] = Common for unswitched -V
- CP [output power (pin 4)] = Common for switched -V

The 24V DC electromechanical brake power is only applicable for brake options B2 and B3. The electromechanical brake power is sourced from 24V DC supplied from receptacle CPBR pin 2 (+) and CPBR pin 3 (-).

Make Connections

The gland plate on the drive has various configurations that are selected when the product is ordered. This section provides detail about the different gland plate options, the receptacle pin out information, and how to make connections.



ATTENTION: Equipment damage or failure could occur. Make sure that all connectors and caps are securely tightened to seal connections properly against leaks and maintain IP67 requirements.

IMPORTANT ArmorConnect connections must be hand-tight. See the ArmorConnect instructions for the recommended tightening torques. The use of a tool to help tighten the connectors is not recommended.

The power, I/O, and EtherNet/IP network connections are made without removing the front cover. All connectors are on the bottom of the enclosure.

Receptacle Configurations on the Gland Plate

For detailed information on the gland plate abbreviations, see [Table 5 on page 47](#).

IMPORTANT These diagrams are applicable to drive ratings 22 amps or 15.4 amps and less. Verify the title before comparing to your configuration. These views are for representation only, check the catalog string for your specific receptacle information. The \$ and the * indicate configuration variables.

Figure 3 - Maximum Possible Receptacle Details Induction Motor 24V DC Brake (≤ 15.4 amps)

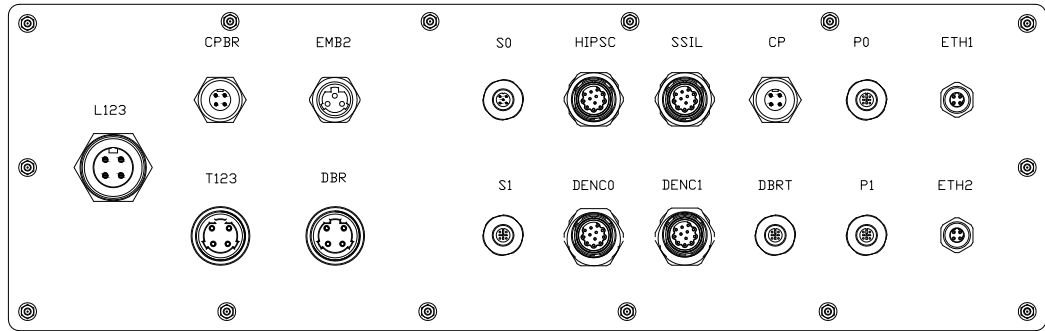

Figure 4 - Maximum Possible Receptacle Details Induction Motor 24V DC Brake (22 amps)

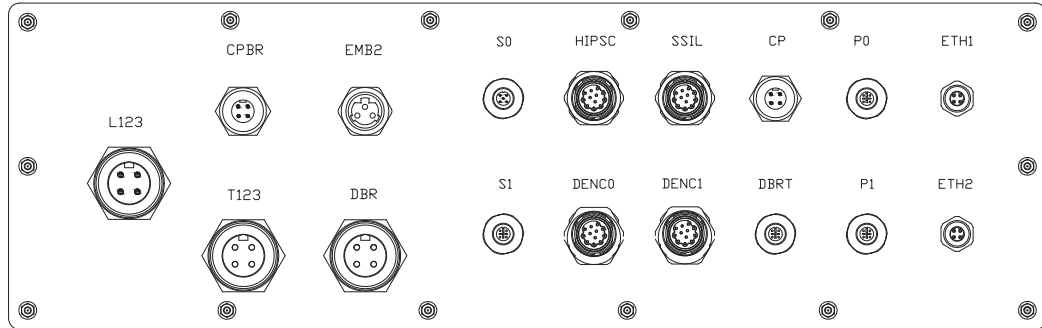

Figure 5 - Maximum Possible Receptacle Details Induction Motor Source Brake (≤ 15.4 amps)

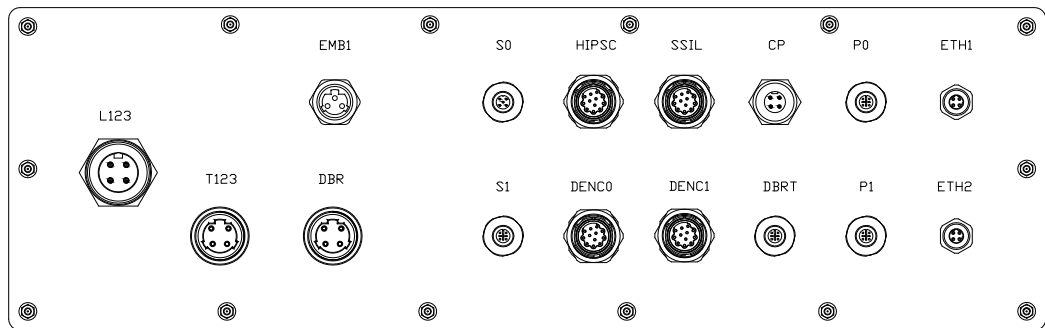

Figure 6 - Maximum Possible Receptacle Details Induction Motor Source Brake (22 amps)

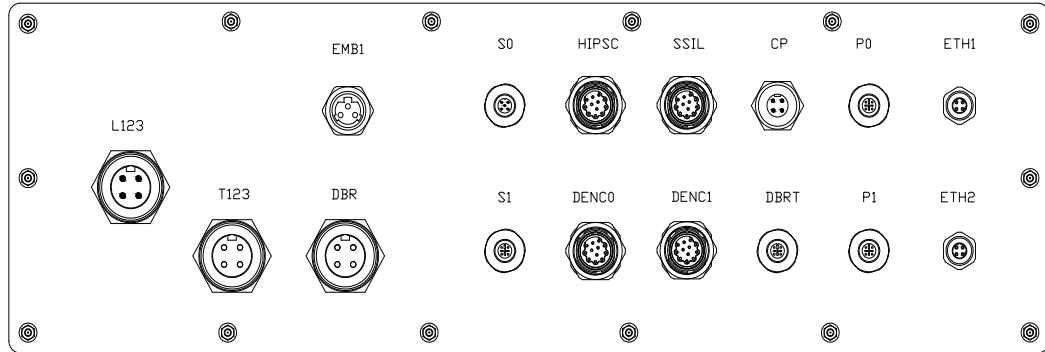

Figure 7 - Maximum Possible Receptacle Details Servo Motor 24V DC Brake (≤ 14 amps)

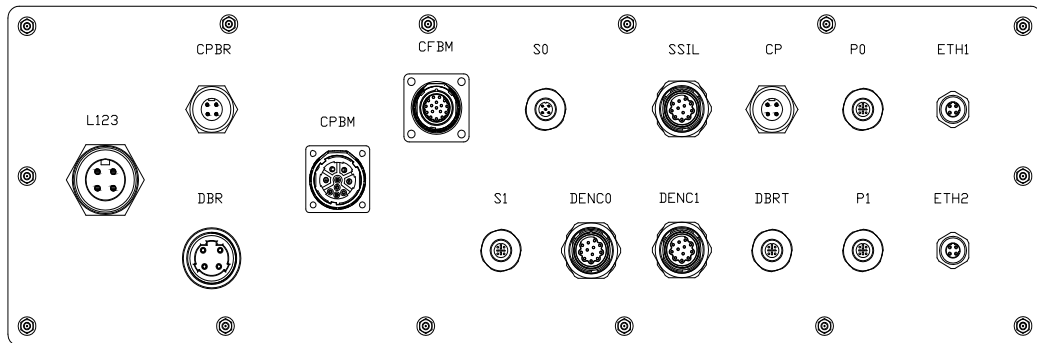
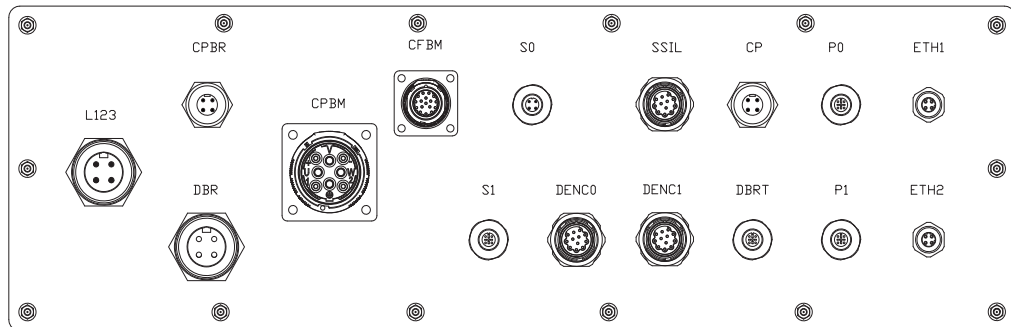

Figure 8 - Maximum Possible Receptacle Details Servo Motor 24V DC Brake (22 amps)



[Table 5](#) defines the gland plate abbreviations and provides a description of the function of the receptacle that is connected. These abbreviations correspond to the terminal designations on the gland plates that are shown in [Figure 3 on page 45...](#)[Figure 8 on page 46.](#)

Table 5 - Drive Gland Plate Abbreviation Definitions

Terminal Designations	Description	Terminal Designations	Description
L123	Input Power	CFBM	Allen-Bradley® Servo Bulk Head Hiperface Encoder
T123	Output Power	CPBM	Allen-Bradley Servo Motor Power and Brake
DRB	Dynamic Brake	ENCO	M23 Incremental Encoder
EMB1	400/480V AC Source Mechanical Brake	HIPSC	M23 Hiperface SC Encoder
EMB2	24V DC Mechanical Brake	SSIL	M23 SSI Linear Encoder
CP	24V DC Control Power	DENCO	M23 Dual Incremental Encoder - 0
CPBR	24V DC Brake Power	DENC1	M23 Dual Incremental Encoder - 1
DBRT	Brake Resistor Thermostat Temperature	SSISC	M23 SSISC Rotary Encoder
S0	S0 Safety (S3)	P0	P0 Digital Input
S0	S0 Network Safety (S4)	P1	P1 Digital Input
S0	S0 Network Safety (S4 with brake)	ETH1	EtherNet/IP Link 1
S1	S1 Network Safety (S4)	ETH 2	EtherNet/IP Link 2

Receptacle Connections

The images that follow are examples of the receptacles and are not to scale. For additional information about using the receptacles, see [Replace Receptacles on the Gland Plate on page 164.](#)

The connectors should be installed in the following order:

1. Ethernet (ETH1 and ETH2)
2. Controls (CP, P0, P1, DBRT, CPBR, and EMB2)
3. Safety (S0 and S1)
4. Encoders (ENCO, HIPSC, SSIL, SSISC, DENCO, and DENC1)
5. Source brake (EMB1)
6. Dynamic brake (DBR)
7. Output power (T123 and CPBM)
8. Input power 400/480V AC (L123)

Power

[L123] Input Power, M35

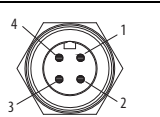

Pin	Function
1	L1
4	L2
3	L3
2	Ground

[CPBM] Allen-Bradley Servo Motor (14 amps or less) Power Output (motor connection) and mechanical brake (24V DC)

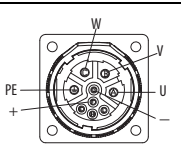

Pin	Function
A	U
B	V
C	W
PE	Ground
F	+
G	-

[CPBM] Allen-Bradley Servo Motor (22 amps) Power Output (motor connection) and mechanical brake (24V DC)

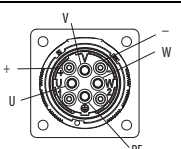

Pin	Function
U	U
V	V
W	W
PE	Ground
+	+
-	-

[T123] Output Power (motor connection), M29

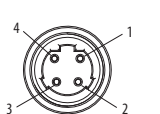

Pin	Function
1	L1
2	L2
3	L3
4	Ground

[DBR] Dynamic Brake Resistor, M29

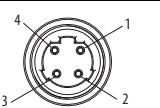

Pin	Function
1	BR1
2	BR2
3	Not used
4	Ground

[EMB1] 400V AC Source Mechanical Brake, M24

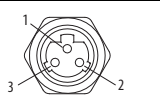

Pin	Function
1	L1
2	L2
3	L3
4	Ground

[T123] Output Power (motor connection), M35

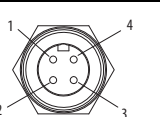

Pin	Function
1	L1
4	L2
3	L3
2	Ground

[DBR] Dynamic Brake Resistor, M35

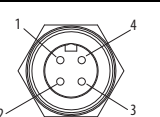

Pin	Function
1	BR1
4	BR2
3	Not used
2	Ground

Control Power

[CP] 24V DC Control Power, Mini male

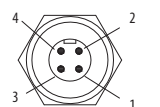

Pin	Function
1	+24V DC
2	+24V DC
3	Common
4	Common

[CPBR] 24V DC Brake Power, Mini male

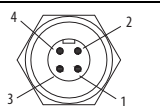

Pin	Function
1	Not used
2	+24V DC
3	Common
4	Not used

[EMB2] 24V DC Induction Motor Brake Contactor, M24

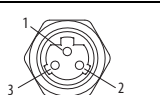

Pin	Function
1	+24V DC
2	+24V DC
3	Common
4	Ground

Control Power (cont.)

[P0] Digital Input, M12, DC micro

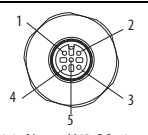

Pin	Function
1	+24V DC
2	I/O-DI3
3	Common
4	I/O-DI2
5	Not Used

[P1] Digital Input, M12, DC micro

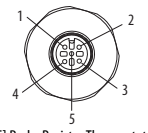

Pin	Function
1	+24V DC
2	I/O-DI5
3	Common
4	I/O-DI4
5	Not used

[DBRT] Brake Resistor Thermostat Temperature, M12, DC micro

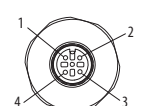

Pin	Function
1	DI 0
2	+24V DC
3	Not used
4	Not used

Safety

[S0] Safety (S3), M12, DC micro

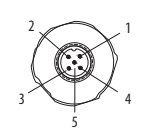

Pin	Function
1	SP
2	SC
3	Not used
4	SI0-SI1
5	Not used

[S0] Network Safety (S4), M12 DC micro

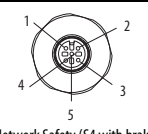

Pin	Function
1	IO1
2	SI1
3	SC
4	SI0
5	IO0

[S0] Network Safety (S4 with brake), M12, DC micro



Pin	Function
1	IO1
2	SI1
3	SC
4	Not used
5	IO0

[S1] Network Safety (S4), M12, DC micro

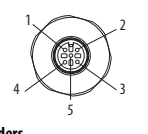

Pin	Function
1	IO1
2	SI3
3	SC
4	SI2
5	IO0

Encoders

[CFBM] Allen-Bradley Servo Bulk Head Hiperface Encoder

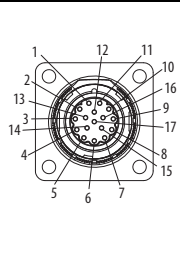

Pin	Function
1	Sine (+)
2	Sine (-)
3	Cosine (+)
4	Cosine (-)
5	Channel X Data (+)
6	Channel X Data (-)
9	Not used
10	Common
12	Common
14	Common
11	+12V DC power
13	Not used

[ENCO] Incremental Encoder, M23

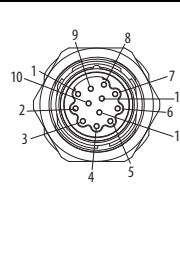

Pin	Function
1	Single track C (K0)
2	Negated signal track C (K0)
3	Signal track A (K1)
4	Negated signal track A (K1)
5	Signal track B (K2)
6	Negated signal track B (K2)
7	Not used
8	Not used
9	Not used
10	Not used
11	Common
12	+12V DC power

Encoders (cont.)

[HIPSC] Hiperface SC Encoder, M23

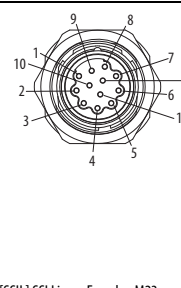

Pin	Function
1	Not used
2	Not used
3	Cosine (+)
4	Cosine (-)
5	Sine (+)
6	Sine (-)
7	Channel X data (-)
8	Channel X data (+)
9	Not used
10	Not used
11	Common
12	+12V DC power

[SSIL] SSI Linear Encoder, M23

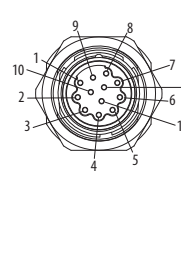

Pin	Function
1	Clock line (+)
2	Negated clock line (-)
3	Not used
4	Not used
5	Not used
6	Not used
7	Dataline (-)
8	Dataline (+)
9	Common
10	+24V DC power
11	Common
12	+12V DC power

[DENC0] Dual Incremental Encoder - 0, M23

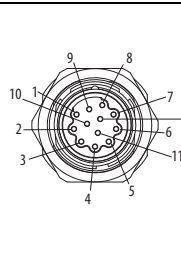

Pin	Function
1	Signal track C (K0)
2	Negated signal track C (K0)
3	Signal track A (K1)
4	Negated signal track A (K1)
5	Signal track B (K2)
6	Negated signal track B (K2)
7	Not used
8	Not used
9	Not used
10	Not used
11	Common
12	+12V DC power

[DENC1] Dual Incremental Encoder - 1, M23

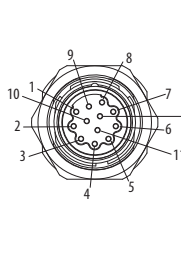

Pin	Function
1	Signal track C (K0)
2	Negated signal track C (K0)
3	Signal track A (K1)
4	Negated signal track A (K1)
5	Signal track B (K2)
6	Negated signal track B (K2)
7	Not used
8	Not used
9	Not used
10	Not used
11	Common
12	+12V DC power

[SSISC] SSI SC Rotary Encoder, M23

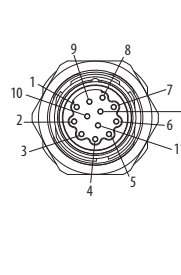

Pin	Function
1	Channel X clock (+)
2	Channel X clock (-)
3	Cosine (+)
4	Cosine (-)
5	Sine (+)
6	Sine (-)
7	Channel X data (-)
8	Channel X data (+)
9	Not used
10	Not used
11	Common
12	+12V DC power

Ethernet

[ETH1] and [ETH2] EtherNet/IP, M12, micro D

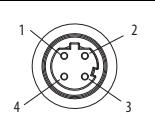

Pin	Function
1	Tx+
2	Rx+
3	Tx-
4	Rx-

Configure and Start Up the Drive

Topic	Page
Prepare for Initial Drive Start Up	50
Set the Network IP Address of the 1783-ETAP	50
Configure the PowerFlex 755 Drive Embedded EtherNet/IP Adapter	51
Energize the HIM	51
Start Up Introduction	56
Drive Start Up – I/O Mode	59
Drive Start Up – Integrated Motion mode (CIP Motion)	112

This chapter includes information to establish communication with the drive via the embedded EtherNet/IP adapter, view adapter status via parameters, configure the basic start up parameters, and how to set or clear a fault action via drive parameters. For detailed information on programming, additional start up information, and troubleshooting of the PowerFlex 755[®] drive, see the PowerFlex 750-Series AC Drives Programming Manual, publication [750-PM001](#).

Start up is performed by using the cover-mounted HIM, Connected Components Workbench™ (CCW) software, Drive Executive™ software, or the Logix Designer application. Start up can also be performed by downloading a locally stored customer template drive file that has the I/O to control the motor brake configured.



ATTENTION: Allen Bradley[®] servo motors must be uncoupled from the load and have a rotate autotune preformed at start up to identify the commutation offset required to produce torque properly. This test cannot be performed with the motor coupled to the load. Failure to comply will result in equipment damage or failure.

IMPORTANT For induction motors that can't be easily uncoupled, an alternative static tune procedure can be used in the autotune portion of start up. However, an uncoupled rotate tune is the recommended method for commissioning.

For questions regarding this requirement contact Rockwell Automation Drives technical support for assistance.

Prepare for Initial Drive Start Up

Gather the following information before proceeding to start up. We recommend that you print this page and keep it available during the start up process. See [Start Up Information on page 207](#) in Appendix B of this document for a printable version of this table. This information is used throughout start up and while in the start up dialog boxes.

Motor Data ⁽¹⁾⁽²⁾		Dynamic Brake Data		Option Module: Safety		Stop Mode		Application Specifics	
Hp/Kw		Ohms		(A) S3 Safe Torque Off – Hardwired		Coast		Accel Rate	
Hertz		Watts		(A) S3 Safe Torque Off – Integrated Safety		Ramp Stop		Decel Rate	
RPM		Watts/sec (joules)		(B) S4 Integrated Safe Speed Monitoring		Current Limit		S Curve	
Volts				(C) S4 Integrated Safe Speed Monitoring with Source Brake				Horizontal / Vertical	
Amps		Mechanical Motor Brake Data		(N) None		Port Assignment		Max Velocity	
# Motor Poles		Current				Position Loop			
		Amps				Speed Loop		Motor Polarity	
		Voltage	24V DC or 400/480 V AC			Universal Feedback Port		Forward Direction	
Ethernet/IP address								Reverse Direction	
Firmware Revision⁽³⁾⁽⁴⁾				Drive Catalog Number⁽⁴⁾					
Drive Rating⁽⁴⁾				Add-on Profile Version					
				HIM		20-HIM-C6S			
Option Module Port Assignment⁽⁵⁾		Port 2	Port 4	Port 5	Port 6	Port 7	Port 8		
		HIM				20-750-2263C-1R2T	20-750-APS		

- (1) The motor data must be entered in Kw when doing installation for integrated motion. (Kw=Hp*0.746)
- (2) If an Allen Bradley permanent magnet servo motor is being used (versus an induction motor), you must look up the AB servo motor part number. Refer to PowerFlex 750-Series AC Drives Technical Data, publication [750-TD001](#) to obtain proper VFD drive settings for the motor being controlled.
- (3) Get help determining how products interact, check features and capabilities, and find associated firmware <https://compatibility.rockwellautomation.com/Pages/home.aspx>. For additional information on how to update drive firmware, see the [Troubleshooting on page 173](#) of this manual.
- (4) Firmware version, drive catalog number, and drive ratings are located on the data name plate. Additional information about the option modules and their slots are located in the electrical schematics.
- (5) Slot 4, 5, and 6 are specific to your application. The option module used is identified in the catalog string definition. See [Catalog Number Explanation on page 16](#) for more information.

Set the Network IP Address of the 1783-ETAP

This section provides instructions and information for setting the parameters to properly configure the embedded EtherNet/IP adapter on the PowerFlex 755 drive. The On-Machine™ drive connects to the network through the 1783-ETAP dual-port Ethernet adapter and supports Device Level Ring (DLR), linear, or star topology using the ETH1 and ETH2 receptacles. The 24V DC control power must be present (via the CP receptacle) to configure the 1783-ETAP dual-port adapter.

Out of box, the ETAP is configured to be a non-supervisor ring node and responds to the default IP address of 169.254.1.1. If your application does not require access to the taps diagnostic information or configuration, no further action is required. Otherwise, set the IP address by using RSLinx® Classic software, the Logix Designer application, or a BOOTP or DHCP server.

See the Ethernet Tap Product Information, publication [1783-PC011](#) for more information on the 1783-ETAP adapter.

IMPORTANT If you use BOOTP or DHCP to set the IP address, only the IP address of the 1783-ETAP module is set. It does not affect the setting of the PowerFlex drive.

Configure the PowerFlex 755 Drive Embedded EtherNet/IP Adapter

You must use the HIM to configure the adapter IP address. The embedded EtherNet/IP adapter stores parameters and other information in nonvolatile storage (NVS) memory. Access the adapter by using the HIM to view and edit these parameters. After the 1783-ETAP dual-port Ethernet adapter is configured, the following tools can then be used to access drive parameters to modify the adapter settings. This manual provides information for using the HIM to set the IP address on the adapter.

For PowerFlex 755 Embedded EtherNet/IP detailed information, see the PowerFlex 755 Drive Embedded EtherNet/IP Adapter User Manual, publication [750COM-UM001](#). For additional reference materials, see the [Additional Resources on page 8](#) table.

Tool	Reference
PowerFlex 20-HIM-C6S HIM	20HIM-UM001
Connected Components Workbench software, version 1.02 or later	http://compatibility.rockwellautomation.com/Pages/home.aspx , or online help (installed with the software)
DriveExplorer™ software, version 6.01 or later	http://compatibility.rockwellautomation.com/Pages/home.aspx , or online help (installed with the software)
DriveExecutive software, version 5.06 or later	http://compatibility.rockwellautomation.com/Pages/home.aspx , or online help (installed with the software)

Energize the HIM

Before beginning start up, make sure that all required input power, control, output motor, brake, safety, encoder, dynamic brake, and I/O cables are correctly connected. Refer to [Make Connections on page 44](#) for more information.

After the information is gathered for [Prepare for Initial Drive Start Up on page 50](#), follow these steps to use the HIM.



ATTENTION: Possibility of equipment damage or personal injury exists. DO NOT Energize the Incoming power (#1) or Mechanical brake circuit breakers (#2) now. See [Figure 9 on page 52](#) for breaker identification.



ATTENTION: Power must be applied to the PowerFlex drive to perform the following start up procedure. Some of the voltages present are at incoming line potential. To avoid electric shock hazard or damage to equipment, allow only qualified service personnel to perform the following procedures. Thoroughly read and understand the procedure before beginning.

1. Open the door for the auxiliary circuit breaker, refer to [Open Auxiliary Circuit Breaker Door on page 176](#) for more information.
2. Energize the 24V DC (#3) control power circuit breaker.

Figure 9 - Circuit Breaker Identification

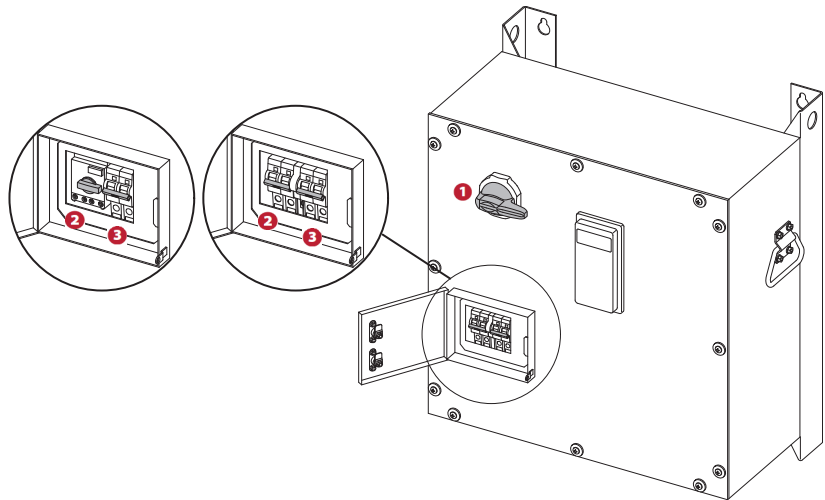

1. 400/480V AC rotary power for main circuit breaker (140G-G6C3-C30-AJ).
2. 24V DC mechanical brake circuit breaker (1489-M2D040) is shown on the enclosure.
The 400/480V AC source mechanical brake circuit breaker (140M-C2E-B25) is shown on the left.
3. 24V DC control power circuit breaker (1489-M2D2040).

3. Verify that the cover-mounted HIM energizes before proceeding to next step. For information on how to use the HIM, see publication [20HIM-UM001](#).

When powering up a new drive for the first time, the HIM runs through an initial operating routine that:

- Prompts you to select a language
- Initiates a drive start up routine
- Initiates a port verification check





The PowerFlex 20-HIM-A6 and 20-HIM-C6S HIM (Human Interface Module), publication [20HIM-UM001](#) describes how you can change the language from the default (English).

Follow the procedures in this chapter to configure the PowerFlex 755 EtherNet/IP address via the cover-mounted HIM.

- [Set the IP Address on page 54](#) of the PowerFlex 755
- [Set the Subnet Mask on page 54](#) of the PowerFlex 755
- [Set the Gateway Address on page 55](#) of the PowerFlex 755

Use the PowerFlex 20-HIM-C6S HIM to Access Parameters

The drive has an enhanced drive HIM, and it can be used to access parameters in the adapter.

1. Verify that all cables are connected properly to the drive (see [Make Connections on page 44](#)).
2. Display the Status screen, which is shown on HIM power up.
3. Use the  or  key to scroll to the Port in which the embedded EtherNet/IP adapter resides (always **Port 13**).
4. To display the Jump to Parameter # entry dialog box, press the PAR# *soft key*.
5. Use the numeric keys to enter the desired parameter number, or use the  or  *soft key* to scroll to the desired parameter number.

For details on how to view and edit parameters, see the PowerFlex 20-HIM-A6/-C6S HIM User Manual, publication [20HIM-UM001](#).

Set the Adapter IP Address

The drive ships with its EtherNet/IP adapter rotary switches factory set to a value of 999. Based on this setting, **13:36 [BOOTP]** determines the source of the adapters EtherNet/IP address. When the adapter IP address switches are set to a value other than 001...254 or 888, **13:36 [BOOTP]** determines the source for the adapter node address.

IMPORTANT Throughout this section, when directed to **cycle power**, use the 24V DC control power circuit breaker shown in [Figure 9 on page 52](#).

IMPORTANT The On-Machine Drive cannot use a BOOTP server to set the node address because of the 1783-ETAP dual-port Ethernet adapter.

Using Adapter Parameters

By default, the embedded EtherNet/IP adapter on a PowerFlex 755 Frame 2 is configured to set its IP address, subnet mask, and gateway address by using a BOOTP server. To use adapter parameters instead, you must first disable BOOTP by using **13:36 [BOOTP]**. Then set the associated adapter parameters as described in the following subsections.

Disable the BOOTP Feature or Change the Source for the Node Address

1. Set the value of **13:36 [BOOTP]** to 0 (Disabled).

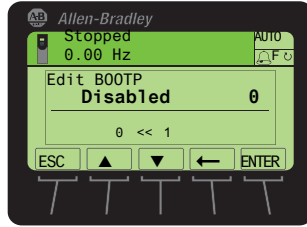

2. Cycle power to the drive to reset the adapter or use the HIM Reset Device function that is in the DIAGNOSTIC folder of the drive.
3. Set the IP address, subnet mask, and gateway address by using adapter parameters. Perform the steps in the following subsections.

Set the IP Address

1. Verify **13:36 [BOOTP]** is set to 0 (Disabled).
2. Set the value of **13:38 [IP Addr Cfg 1] ... 13:41 [IP Addr Cfg 4]** to a unique IP address.

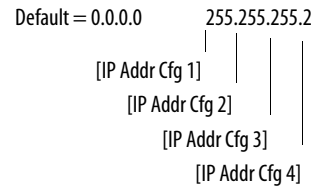
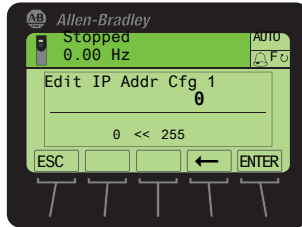

3. Cycle power to the drive to reset the adapter or use the Reset Device function of the HIM, in the DIAGNOSTIC folder for the drive.
The ENET status indicator is steady green or updates green if the IP address is correctly configured.
4. Review **13:37 [Net Addr Src]** to verify it indicates 1-Parameters.

Set the Subnet Mask

1. Verify **13:36 [BOOTP]** is set to 0 (Disabled).
2. Set the value of **13:42 [Subnet Cfg 1] ...13:45 Subnet Cfg 4]** to the desired value for the subnet mask.

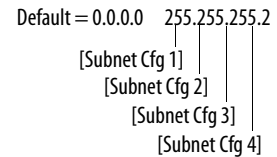
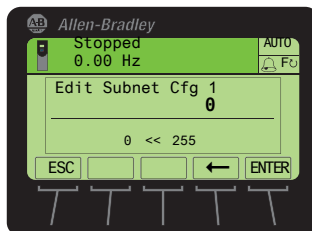

3. Cycle power to the drive to reset the adapter or use the Reset Device function of the HIM in the DIAGNOSTIC folder for the drive.

Set the Gateway Address

1. Verify **13:36 [BOOTP]** is set to 0 (Disabled).
2. Set the value of **13:46 [Gateway Cfg 1] ... 13:49 [Gateway Cfg 4]** to the IP address of the gateway device.

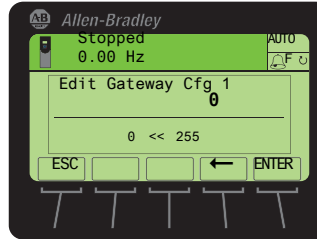

Default = 0.0.0.0 255.255.255.2
 [Gateway Cfg 1]
 [Gateway Cfg 2]
 [Gateway Cfg 3]
 [Gateway Cfg 4]

3. Cycle power to the drive to reset the adapter or use the HIM Reset Device function that is in the DIAGNOSTIC folder of the drive.

Set the Data Rate

By default, the adapter is set to autodetect, so it automatically detects the data rate and duplex setting that is used on the network. If you must set a specific data rate and duplex setting, use the **13:50 [Net Rate Cfg]** value. This value determines the Ethernet data rate and duplex setting that the adapter uses to communicate.

1. Set the value of **13:50 [Net Rate Cfg]** to the data rate at which your network is operating.

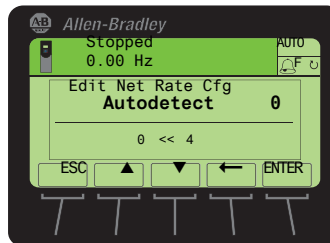

Value	Data Rate
0	Autodetect (default)
1	10 Mbps Full
2	10-Mbps Half
3	100 Mbps Full
4	100-Mbps Half

IMPORTANT Auto detection of communication rate and duplex works only if the device (usually a switch) on the other end of the cable is also set to detect the baud rate/duplex. If one device has the baud rate/duplex hard-coded, the other device must be hard-coded to the same settings.

2. Cycle power to the drive to reset the adapter or use the Reset Device function of the HMI in the DIAGNOSTIC folder for the drive.

Start Up Introduction

The human interface module (HIM) displays the general start-up menu by default upon initial power up of the drive. To navigate to the start-up menu after the initial power up of the drive, press the  (Folders) key.

IMPORTANT If a startup routine is initiated, but must be terminated before the routine is completed, be sure to press the ABORT soft key to exit the routine.

Decide which method of control you want to use within the Studio 5000 Logix Designer application to control the drive: I/O mode or Integrated Motion mode. Verify the Add-on Profile (AOP) and firmware versions that you need. The Product Compatibility and Download Center (PCDC) can help you find product-related downloads including firmware, release notes, associated software, drivers, tools, and utilities. The PCDC can be accessed using this link <https://compatibility.rockwellautomation.com/Pages/home.aspx>.

TIP For setup, configuration, and replacement information of the real-time clock, refer to the PowerFlex 750-series AC Drives Reference Manual, publication [750-RM002](#).

Controller Organizer

All configuration and commissioning steps are shown using the Logix Designer application. Double-click the folder with the appropriate name to open the corresponding configuration information.

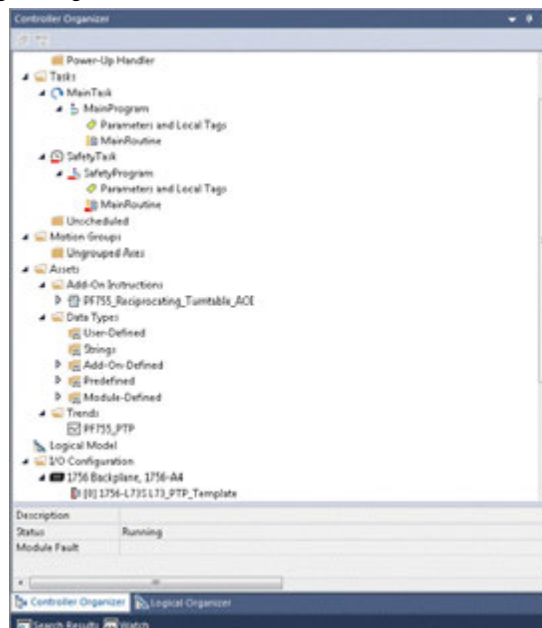

Add-on Profiles

There are separate Add-on Profiles for the Logix Designer application for each of these Modes of control, along with the safety option module used in the drive. See the On-Machine drive [Catalog Number Explanation on page 16](#) to identify which safety option module is installed in your drive as indicated in the [Data Nameplate and UL Listing on page 12](#) section.

Each option has different minimum system requirements depending on the safety controller series that is used, Logix controller firmware, and the drive firmware level. These requirements are summarized in [Table 6](#).

Table 6 - Safety Controller System Requirements

Safety Option Module ⁽¹⁾		20-750-53 Integrated Safe Torque Off Module		20-750-54 Integrated Safety Functions Module	
Mode of Operation		I/O mode	Integrated Motion mode	I/O mode	Integrated Motion mode
Minimum Drive Firmware Required		Version 13	Version 14	Version 14	Version 14
Minimum Controller Firmware Required	GuardLogix® 5570, Compact GuardLogix 5370, Armor GuardLogix 5570 Controllers	Version 30	Version 31	Not supported	Not supported
	GuardLogix 5580, Compact GuardLogix 5380 Controllers	Version 31		Version 31	

(1) All versions listed are minimum version requirements. Later versions are also acceptable.

Configuration Requirements

To use integrated safety, the PowerFlex 755 firmware revision must be version 14.00 or later. If you require PowerFlex 755 firmware ControlFLASH™ files to update your unit, go to the product compatibility download center ([PCDC](#)) to download the required PowerFlex 755 files. See the information you collected in the table from [Prepare for Initial Drive Start Up on page 50](#).

TIP This may include firmware, up-to-date AOPs for both Integrated Motion (V19.00), and all PowerFlex drives (V5.03 in this example).

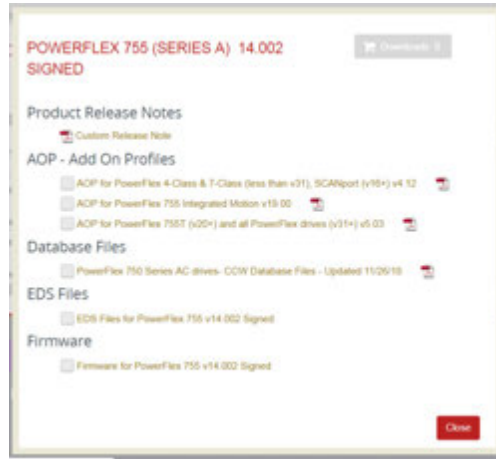

IMPORTANT Before you can configure your drive in the Logix Designer application, you must have a controller project with an EtherNet/IP network connection configured and Time Sync enabled. See the documentation for your controller for information on configuring those products. For safety applications, you need a GuardLogix or Compact GuardLogix safety controller.

Choose Start Up Mode

Two options are available for integrating the PowerFlex 755 drive with Logix controllers. The bullets below help you determine when to use which mode:

Drive I/O Mode

Drive I/O mode uses Drive Add-on Profiles (AOPs) with Studio 5000 environment. Version 30.00 and later of Studio 5000 Logix designer is used for Network Integrated Safety Function (S4) and version 20.00 and later is used for Safe Torque Off (S3).

- The I/O mode on EtherNet/IP application is a Studio 5000 environment feature. It provides a similar user experience as the Rockwell Automation AC drives that are used with Logix controllers on an EtherNet/IP network, such as: PowerFlex 523, 525, 70, 700, and 753.
- Applications such as fans, pumps, conveyors, and simple position applications such as turntables, framers, trunnions, and vertical lifts.
- I/O mode does not use motion instructions, but uses AOPs to create and store drive parameters and Logix tags to control the drive.

Integrated Motion Mode

Integrated Motion mode uses Integrated Motion on EtherNet/IP technology with Studio 5000 environment software. Version 31.00 of Studio 5000 environment and later with an L8 processor is required with Network Integrated Safety Function (S4) option modules used in the On-Machine drive.

- The Integrated Motion mode on EtherNet/IP application is a PowerFlex 755 drive feature. It provides a similar user experience as the Rockwell Kinetic Servo drives that are used with Logix controllers (L8S version 31.00 and later) on an EtherNet/IP network.
- Applications having both servos and drives - convenient to be able to configure/program servos and drives the same way.
- Drive applications that could benefit from motion instructions - servo performance is not needed, but it is advantageous to use the Studio 5000 motion instruction set to save development time.
- Applications such as closed-loop position control with coordination of multiple drives.

See the Parameter / Instance Attribute Mapping tables in [750-PM001](#) to view which drive parameters correlate to motion attributes. If a parameter is not listed, it is not accessible and its function is not available.

Drive Start Up – I/O Mode

Use the Logix Designer application and verify that the GuardLogix or Compact GuardLogix controller firmware is at the minimum required level to allow the drive to be controlled properly.

In these steps, we use a GuardLogix 1756-L73S controller with V32.00 firmware and a PowerFlex 755 V14.00 firmware drive. The Add-on Profile (AOP) for the drive is V5.06 or later.

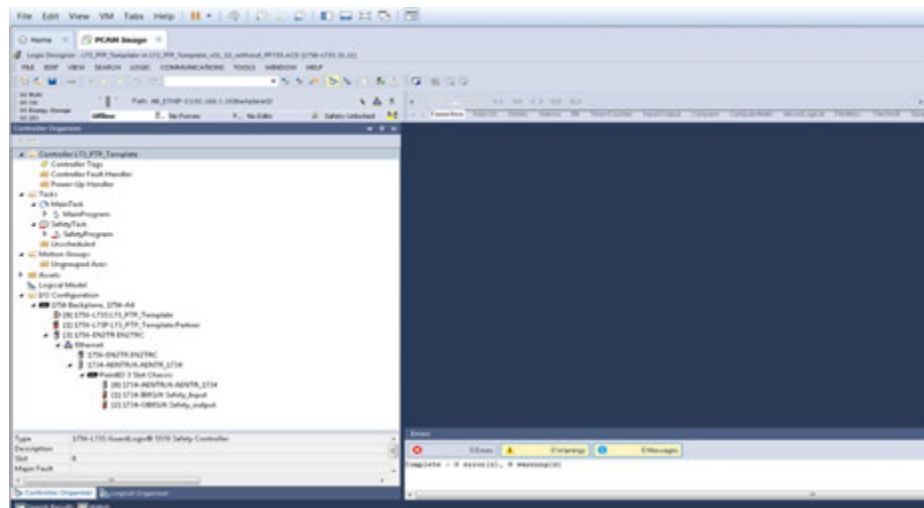

TIP The procedure is written for the Network-Integrated Safe Torque Off (S3) option module. The same procedure, with slight modifications, works for both Network-Integrated Safety Function (SSM) and Network-Integrated Safety Function with Brake Control (S4) option modules.

TIP Variations to the procedure for the SSM or S4 option modules, will appear as tips throughout the procedure.

TIP For SSM and S4, an L8 series processor (L8xS) is required or a Compact GuardLogix 5380S controller.

Add the PowerFlex 755 Drive to Your Project

Before adding your PowerFlex 755 drive to your project, you can configure the safety level. If you are not configuring a safety level, skip to [step 3](#) of this section.

1. To configure the safety level, right-click on the Controller from the Project Tree, and select Properties.
2. On the Safety Tab, set the Safety Level to SIL3/PLe.

This populates the I/O tree with the safety processor and its partner.

TIP If you do not want the safety partner, select SIL3/PLd.

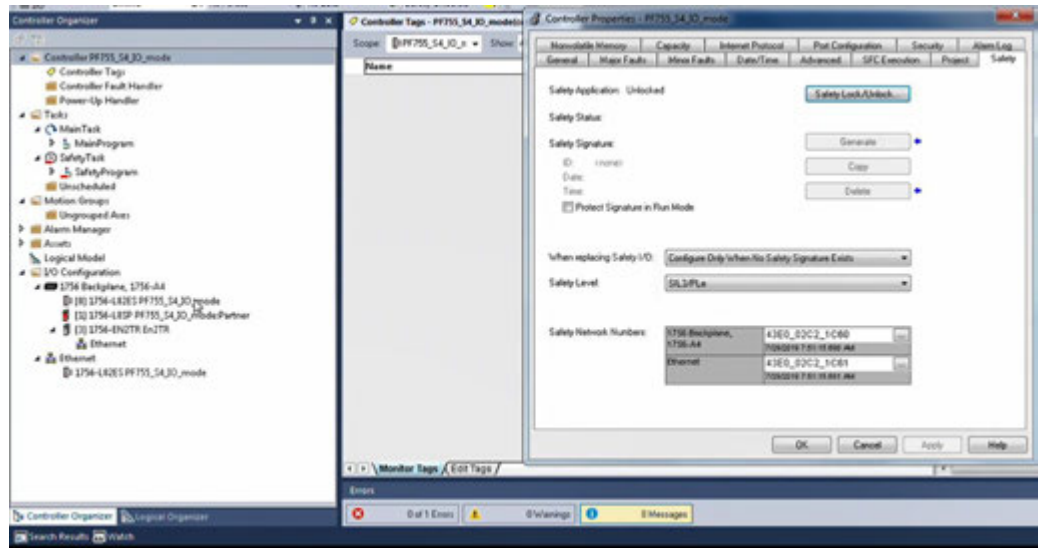

- Right-click the Ethernet network in the Controller Organizer and select New Module to add the PowerFlex 755 drive to the EtherNet/IP network.

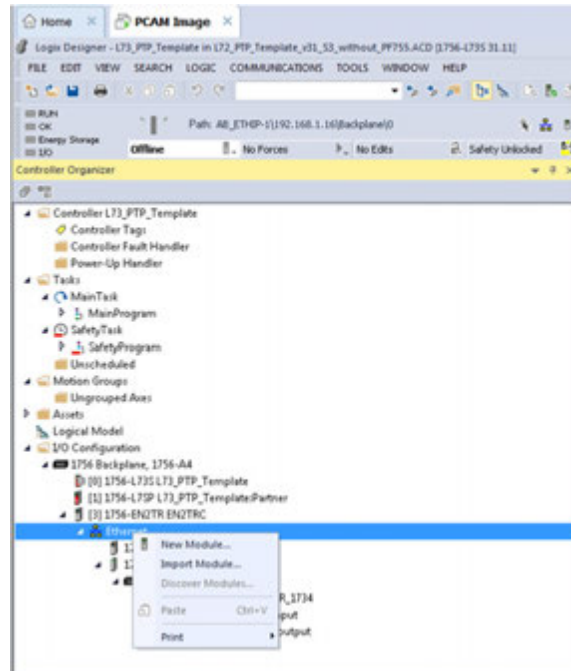

- In the Select Module Type dialog box, type PowerFlex 755.
- Scroll through the list and select PowerFlex 755-EENET (for AC drive via Embedded Ethernet). This is added to the EtherNet I/O card in slot 3 of the Logix rack.

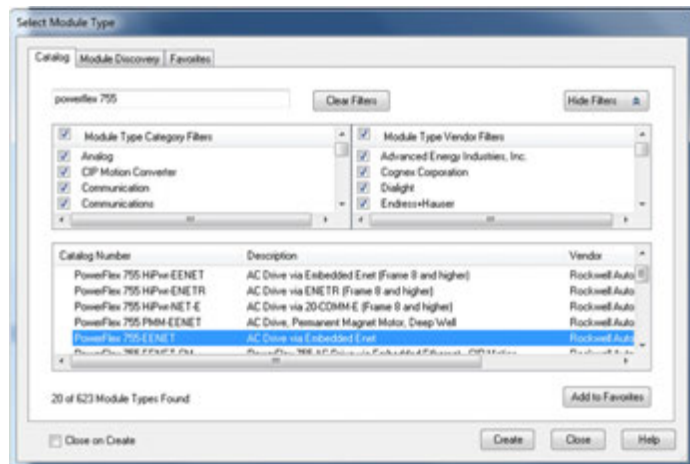

6. On the Identity page of the Device Definition dialog box, type a Name, Description (optional), and the IP address of the drive. In this example, we use PowerFlex 755_PTP_Turntable and an IP address of 192.168.1.56.

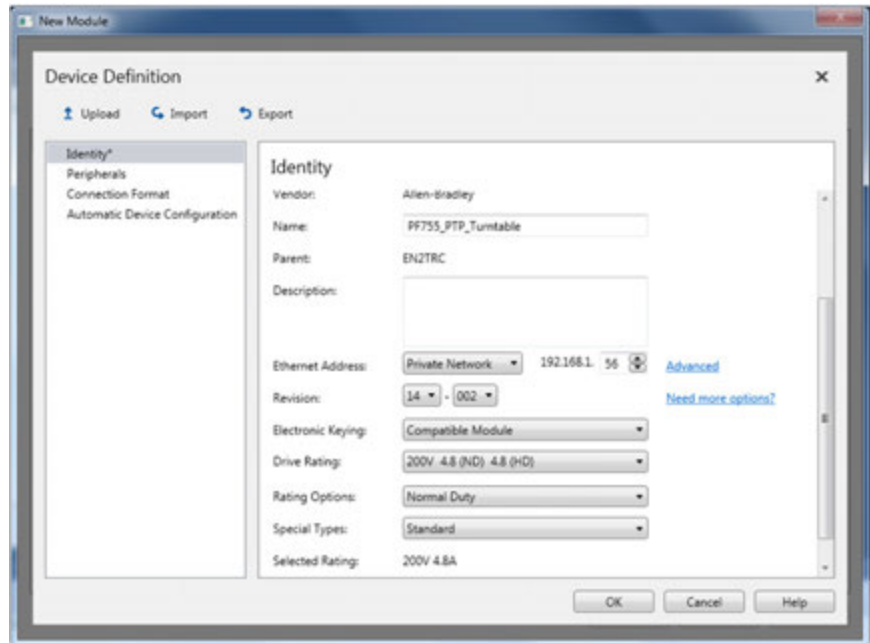

7. Click OK.
8. Click Create to add the drive to the I/O tree.

Update the Module Properties

There are three ways to add the drive data that is required to populate the module properties.

- [Import a Template File on page 63](#) that is loaded on your computer
- [Upload Data from the Drive on page 63](#) (only if powered up and available on your EtherNet/IP network)
- [Enter the Information Manually on page 64](#)

Import a Template File

1. From the Overview page, click Device Definition.
2. On the Device Definition dialog box, click Import to open File Explorer.
3. Navigate to the template file and select the file.
4. Click Open to complete the import.

The drive information imports.

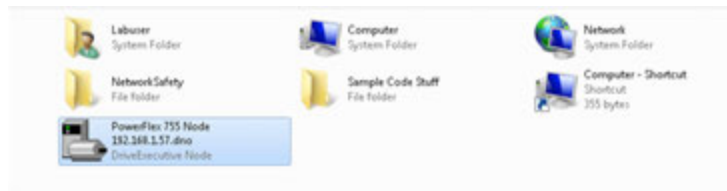

5. See [Verify Drive Data on page 66](#) to confirm that the data was properly imported.

Upload Data from the Drive

1. On the Overview page, click Device Definition. In the Device Definition dialog box, click Upload to open RSLinx software and scan the network.

2. Select the drive IP address that you want to import into the Logix PowerFlex 755 Device Definition and click Continue.

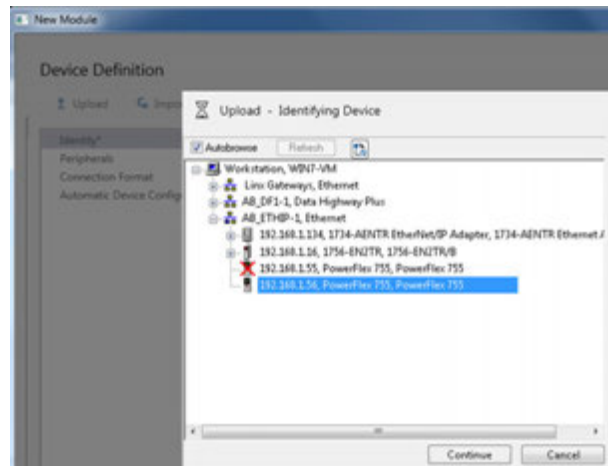

While the Logix Designer application imports the drive information, it shows a status bar, which indicates the progress.

3. Review the uploaded information on the status dialog box and make any necessary changes.
4. Click Continue to finish the upload.

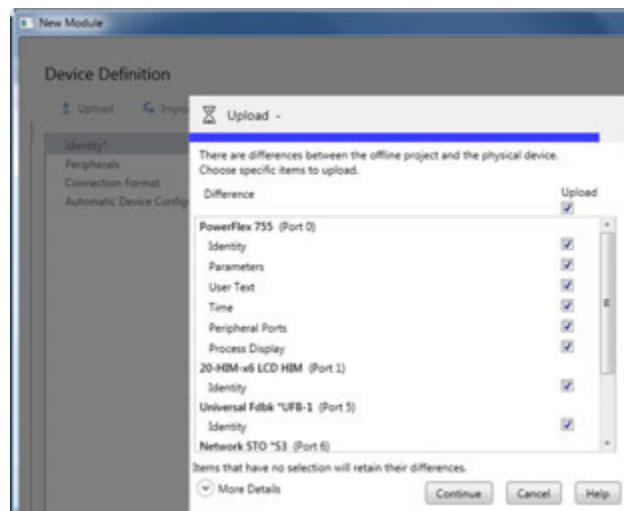

5. See [Verify Drive Data on page 66](#) to confirm that the data was properly imported.

Enter the Information Manually

IMPORTANT Manual entry of the information should only be performed by an expert.

1. On the Overview page, click the Device Definition dialog box.
2. On the Device Definitions dialog box, select the Drive Rating.

3. Select the firmware levels.

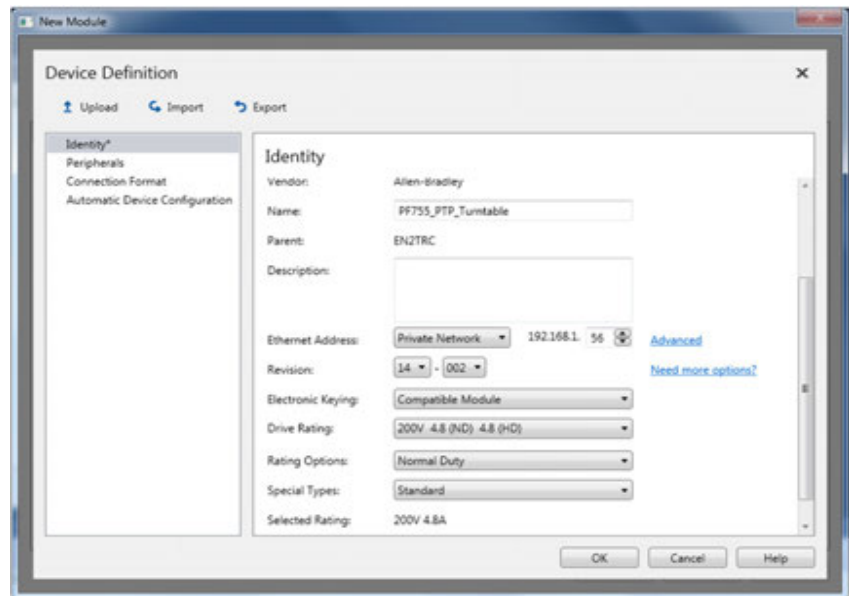
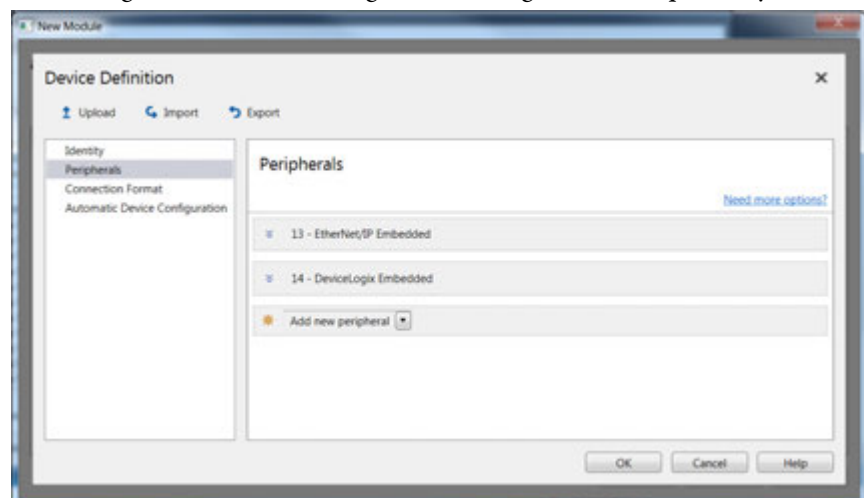
4. Choose the Peripherals page to add the modules identified in the [Data Nameplate and UL Listing on page 12](#) section. See [Catalog Number Explanation on page 16](#) for more information. The slots are auto-assigned, but can be reassigned for configuration compatibility.

- TIP** For this example, the SSM and S4 drive has:
- HIM (20-HIM-C6S) is in slot 2
 - Universal feedback (UFB-1) is in slot 5
 - Network SSM / S4 is in slot 6
 - I/O Module (2263C-1R2T) is in slot 7
 - Auxiliary power supply (APS) is in slot 8

IMPORTANT Refer to the chart in [Prepare for Initial Drive Start Up](#) to make sure that the option modules are in the correct slots. Use those slot assignments here.

5. Click OK.
6. See [Verify Drive Data on page 66](#) to confirm that the data was properly entered.

Verify Drive Data

1. After the data is entered, review the Overview page to verify that the data matches the drive being commissioned.
2. Check the PowerFlex 755 drive part number to confirm which option modules are included, and in which port they are stored, to verify that they match.

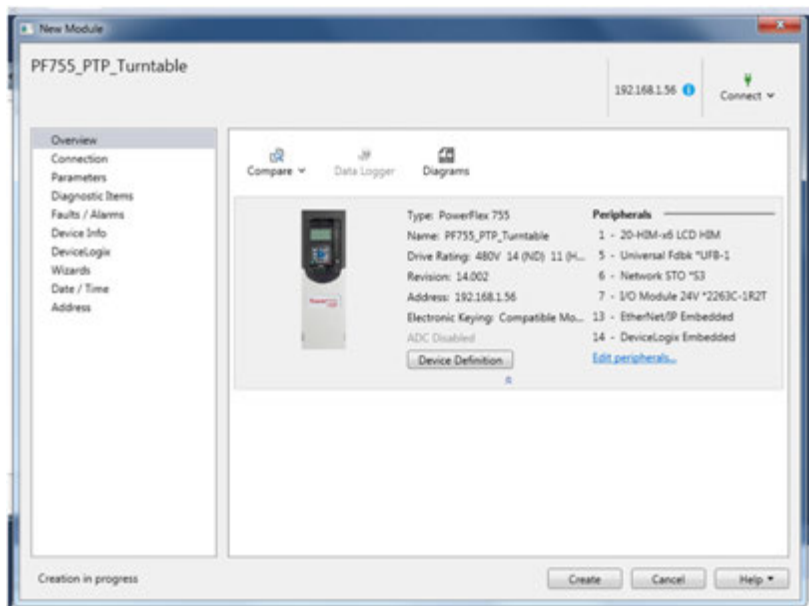

TIP For SSM and S4, complete [Choose Integrated or Hard-wired Safety on page 67](#) and [Safety Configuration for SSM and S4 on page 69](#) before clicking Create.

3. Click Create to add the drive to your Logix Designer application project.
4. Click Close on the Select Module Type dialog box to close it.

Choose Integrated or Hard-wired Safety

When a safety option module is installed in the PowerFlex 755 On-Machine Drive, you must decide if you want to use integrated (network) safety or hardware-based (hard-wired) safety.

Safety Option Module - Slot 6	
Code	Type
A ⁽¹⁾	Safe Torque Off Module (STO) S3 [20-750-S3]
B ⁽²⁾⁽³⁾ (4)	Network-Integrated Safety Function (Safe Speed Monitoring) S4 [20-750-S4]
C ⁽²⁾⁽³⁾	Network-Integrated Safety Function with Source Brake (S4) [20-750-S4]
N	None

- (1) Safe Torque Off can be either network based or hardwired based on the configuration.
 (2) Integrated Safety Function option module requires V13.00 or later firmware.
 (3) Options B and C require, at a minimum, selection of one of the following options: E42, E43, E44, E51, E52, E53, E55, E56.
 (4) If a 20-750-S4 safety option module is used, you must use integrated safety.

1. Double-click your drive in the Controller Organizer to open the drive Module Properties.
2. On the Overview page, click Device Definition to review the drive settings.
3. Observe the Connection type.
 - If the drive connection type is Standard (hard-wired), the safety option module I/O connection that is shown on the electrical schematics must be wired to an appropriate safety I/O device or safety relay via the receptacle that is labeled SO to provide the safety function.

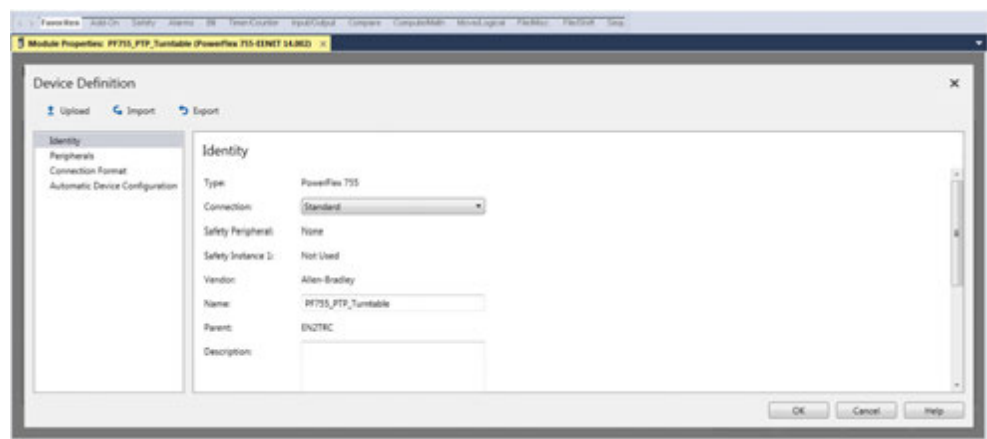

- If you want to use Integrated Safety over the network, the connection type must be Standard and Safety.

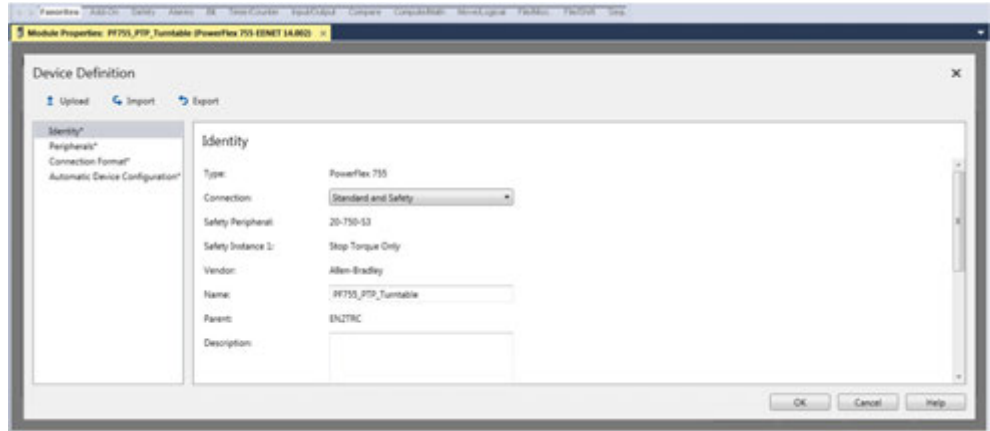

TIP For SSM and S4, continue reading.

- If you want to use Network-Integrated Safety Function (SSM) or Network-Integrated Safety Function with Brake Control (S4), the connection type must be Standard and Safety (20-750-S4).

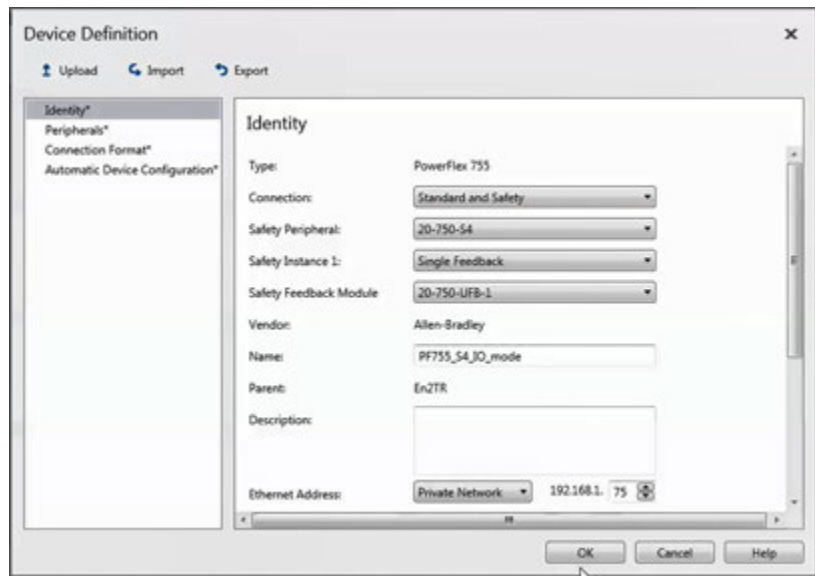

4. To change the connection type, use the pull-down menu to select another type. Click OK.

5. Then click Yes to proceed.

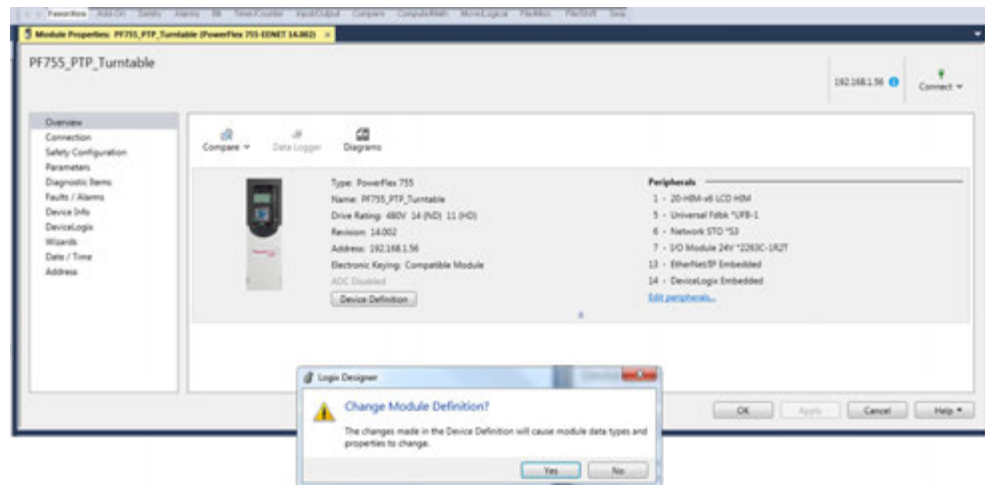

Safety Configuration for SSM and S4

TIP The steps that follow are a result of the sample configuration that was selected. Refer to PowerFlex 755/755T Integrated Safety Functions Option Module, publication [750-UM005](#) for additional information.

IMPORTANT Only reset ownership if your drive safety card was previously owned by a different controller.

Safety configuration for the S3 card can only be done when online, refer to section [Create a Safety Program to Control the Drive Safety Circuits](#) for more information.

IMPORTANT If configuring the system for Network-Integrated Safe Torque Off (S3), **DO NOT** complete this section.

1. Review and verify that information on the drive overview page.

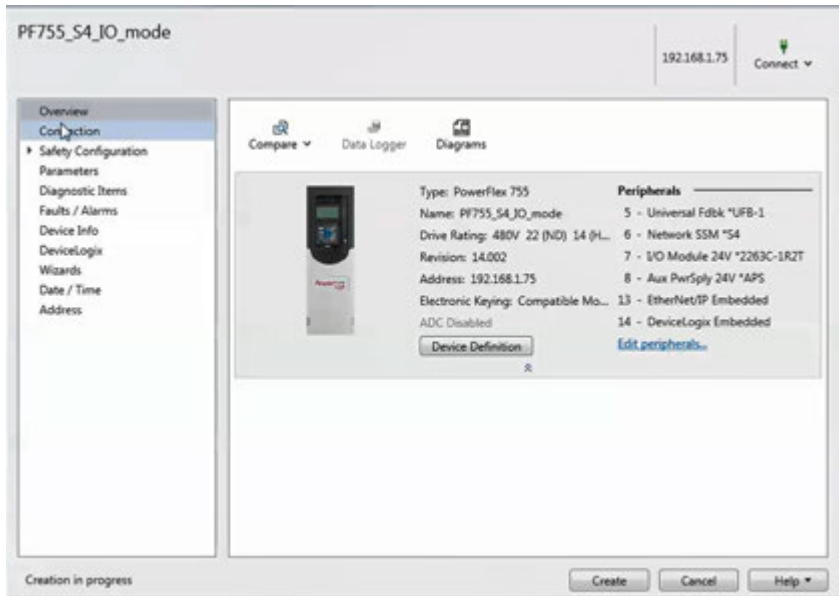

2. On the Overview page, select Safety Configuration.

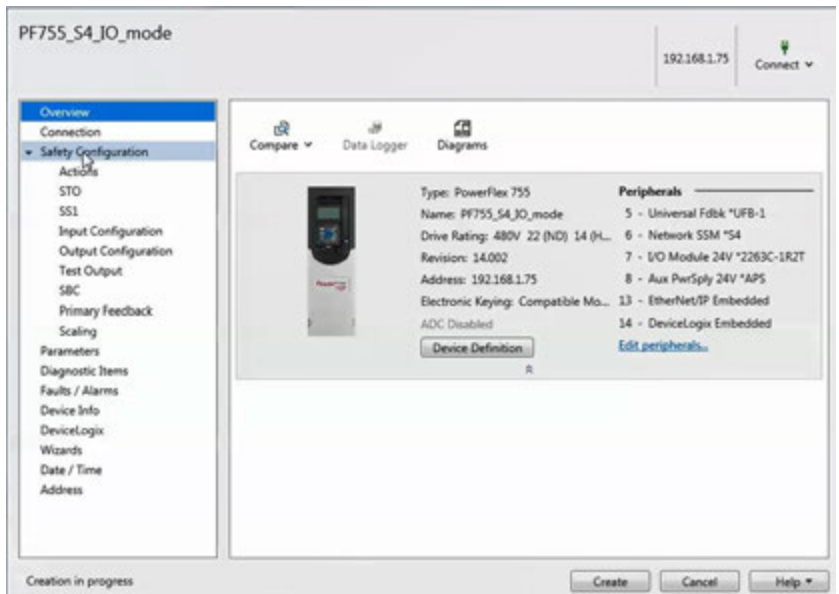

3. Select Actions.

- Change Actions to determine how the system should respond if communication to the device is disrupted.

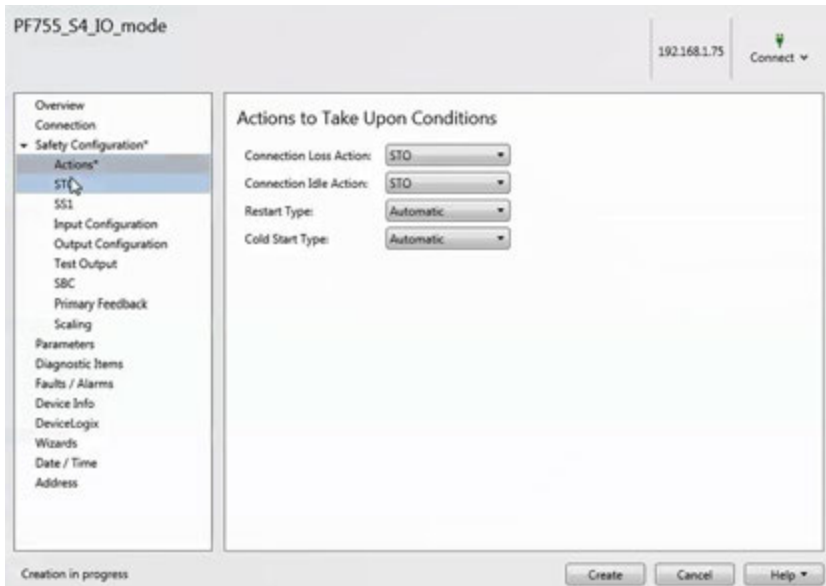

- Select the STO tab, review graph.
- Select the SS1 tab, the information here can be setup in the drive or in the PLC.
- If using Time Safe Speed in Guard Logix, change Stop Delay to 1000 ms.

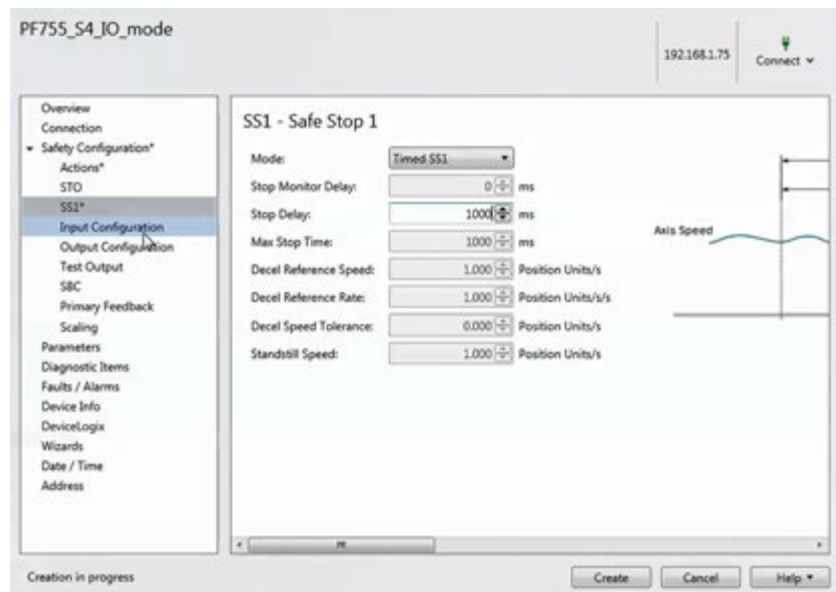

TIP For the SSM or S4 the Input Configuration, Output Configurations, and Test Output need to be set. Refer to the PowerFlex 755/755T Integrated Safety Functions Option Module (S4), publication [750-UM005](#).

- Select the Primary Feedback tab. If you plan to use Safe Speed Monitoring, choose Type >Hyperface.

If you want a fault to occur in the system if a maximum speed or maximum acceleration is exceeded, set values in the right column. This is not safety related, it only pertains to operational limits..



9. Select the Scaling tab. If you plan to use the SXF command, enter the value 4096 into the Position Scaling field.

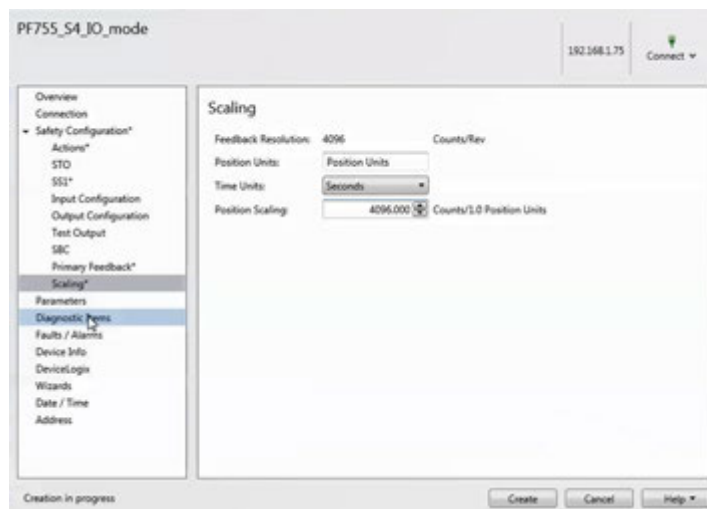

10. Click Create or Apply.

Configure the Drive Parameters

Use the PowerFlex 755 Startup Wizard to create and configure the parameters in the drive with the data that is collected in [Prepare for Initial Drive Start Up on page 50](#).

The PowerFlex 755 Startup Wizard has configuration options to configure the drive parameters for the drive application. Some screens do not require information now, but you must advance through all screens. After completing

each step in the Startup Wizard, click Next to accept the configuration and move to the next step.

TIP The system is currently offline from both the Logix Designer application and the drive.

1. On the Overview page, choose the Wizards page.

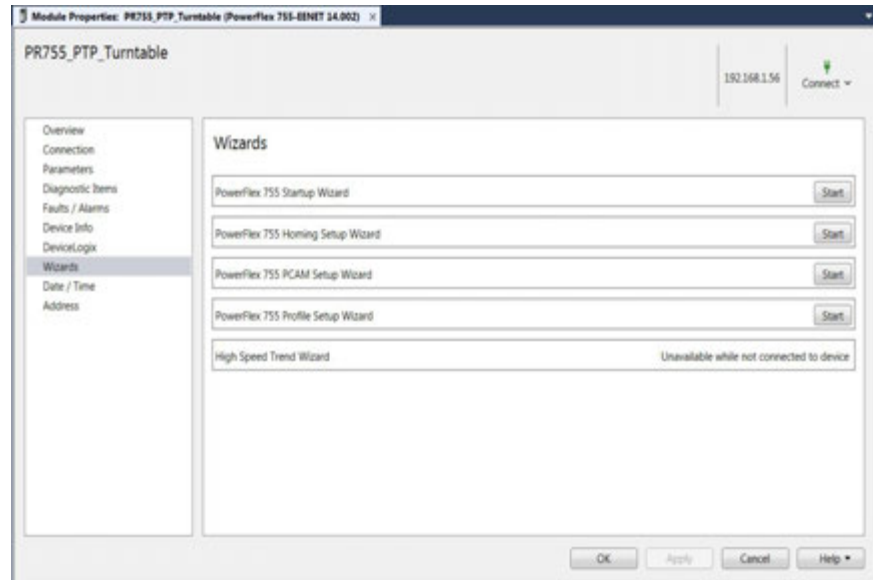

2. Click Start to run the PowerFlex 755 Startup Wizard.

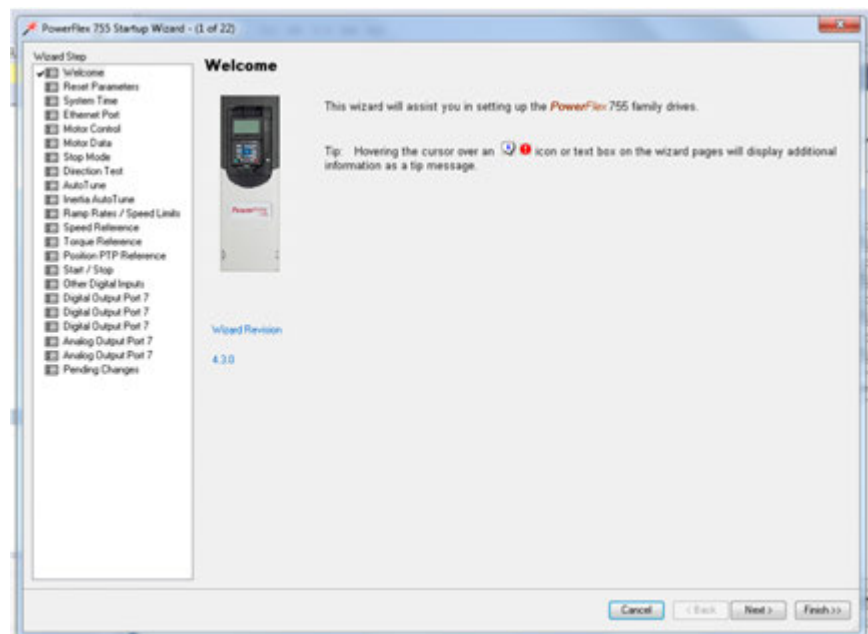

3. Click Next until you advance to the Ethernet Port step.
4. On the Ethernet Port step, change Idle fault action from Fault to Stop (adjust this setting to the most appropriate setting for your application). Click Next.

This determines how the drive responds if it loses its EtherNet/IP connection to the Logix controller. Fault while running or when idle is the default configuration.

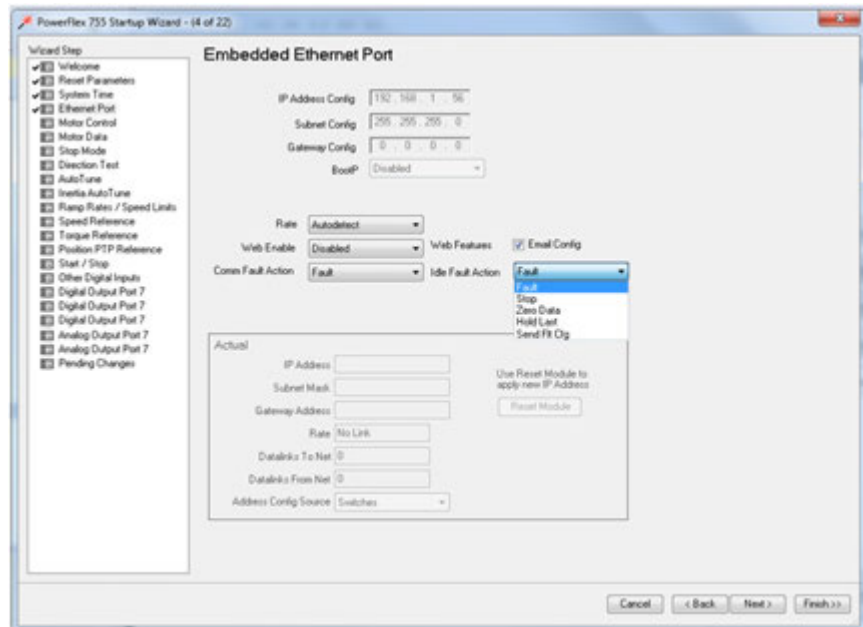

5. On the Motor Control step, select: Motor Control Mode, Speed Units (RPM is standard), and Feedback Encoders that are used for the Speed and Position feedback (these typically match). Click Next.

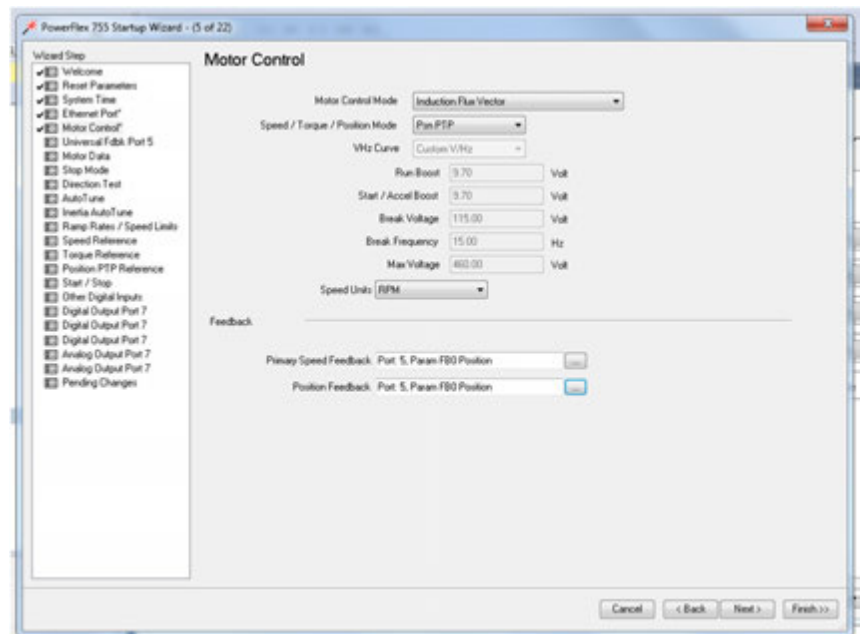

A Universal Feedback device is used in this example, which is compatible with various encoder types. See the catalog string to confirm encoder type for your drive. Position *r* and *s* in the [Catalog Number Explanation on page 16](#) provide this information, the catalog string for your drive can be found on table completed during [Prepare for Initial Drive Start Up on page 50](#).

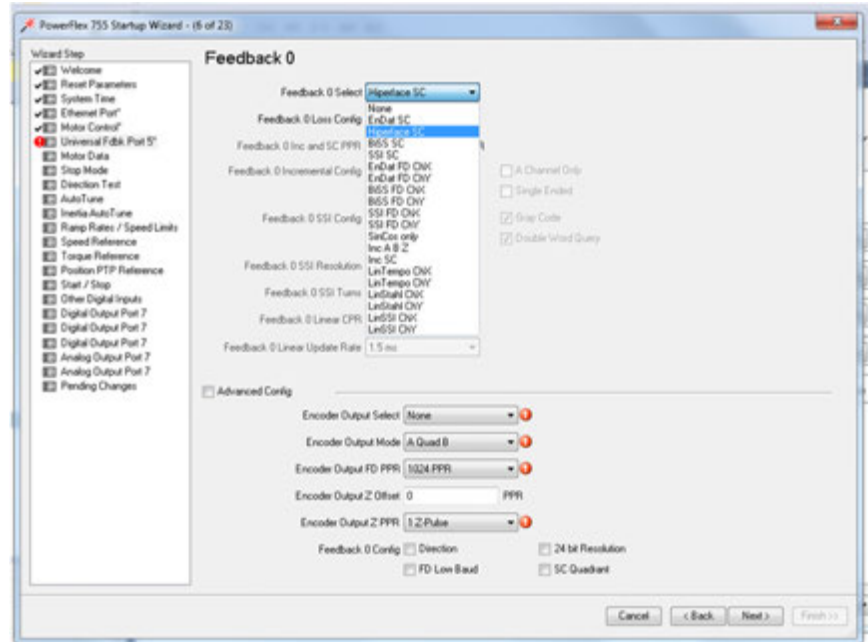

6. On the Motor Data step, enter the Motor Nameplate data. Click Next. This information is found in the [Prepare for Initial Drive Start Up on page 50](#) table.

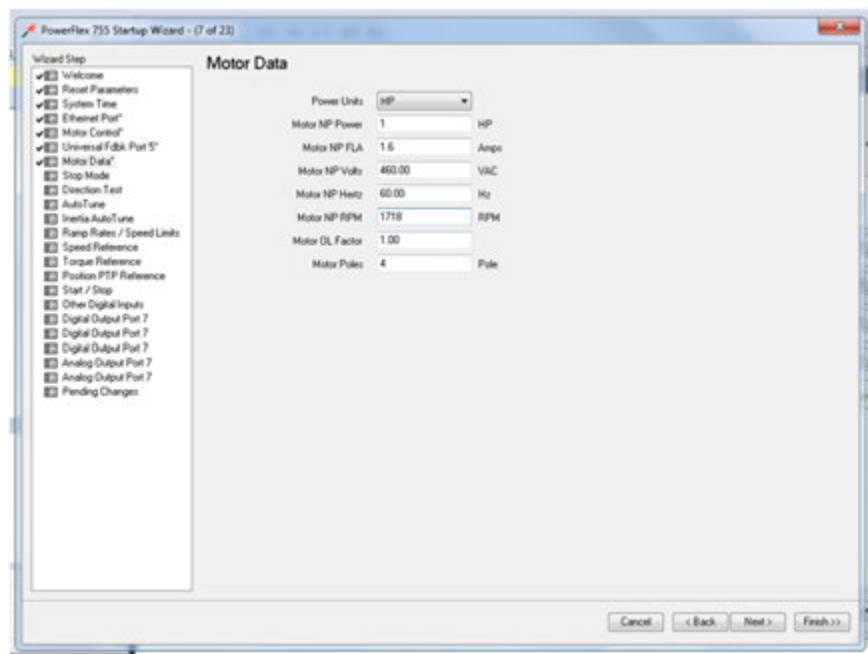

7. On the Stop Mode step, enter the desired stop/brake mode along with the dynamic brake resistor data collected before startup. Click Next.

IMPORTANT If customer supplied protection is to be used in place of the calculated resistor thermal protection for the drive, set the [DB ExtPulse Watts] to its maximum value.

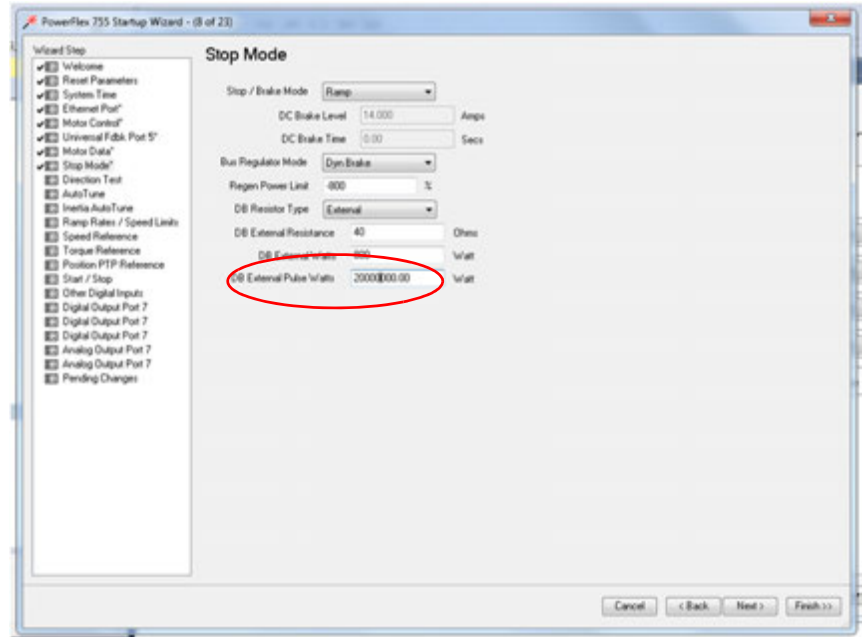

TIP In the PowerFlex 750-Series Programming manual, publication [750-PM001](#), P385 max is 100,000,000. 2million is used here as an example. In the On-Machine Drive, DBRT provides the normally-closed thermostat feedback that is used to protect the Db resistor.

- Because Direction Test, Autotune, and Inertia Autotune tests cannot be performed offline. Click Next.

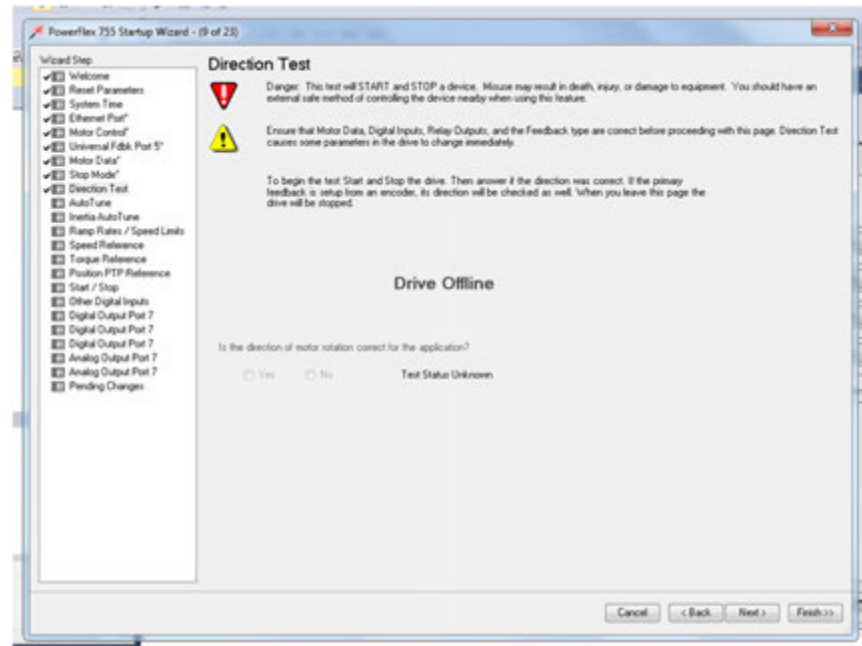

- On the Ramp Rates / Speed Limits step, set the Max Forward and Reverse speed limits for the motor. Click Next.

If the drive is being used for positioning, the maximum speeds should be set +/- 10% higher than the highest commanded move speed. This allows the position loop to close out position errors.

- Set the speed Accel Time 1 and Decel Time 1 to the desired rates. Click Next.

Decel 1 time is the rate that is used on a ramp stop regardless of what mode the drive is configured for (Speed or Position mode). It is followed anytime a stop request is issued.

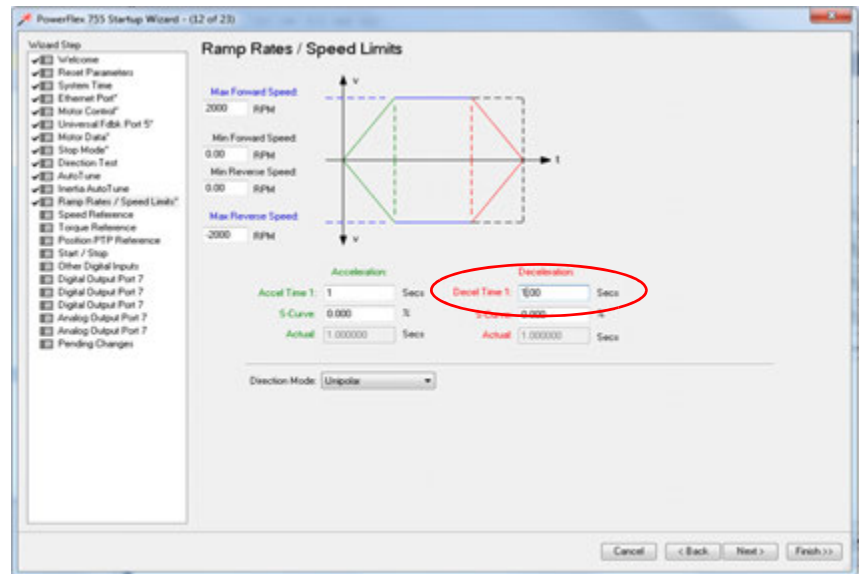

TIP Refer to [Prepare for Initial Drive Start Up](#) for information.

- On the Speed Reference step, click the ellipse and use the pull-down menus to select the Port and Parameter for the source of Speed reference for the drive. This information comes from Ethernet.

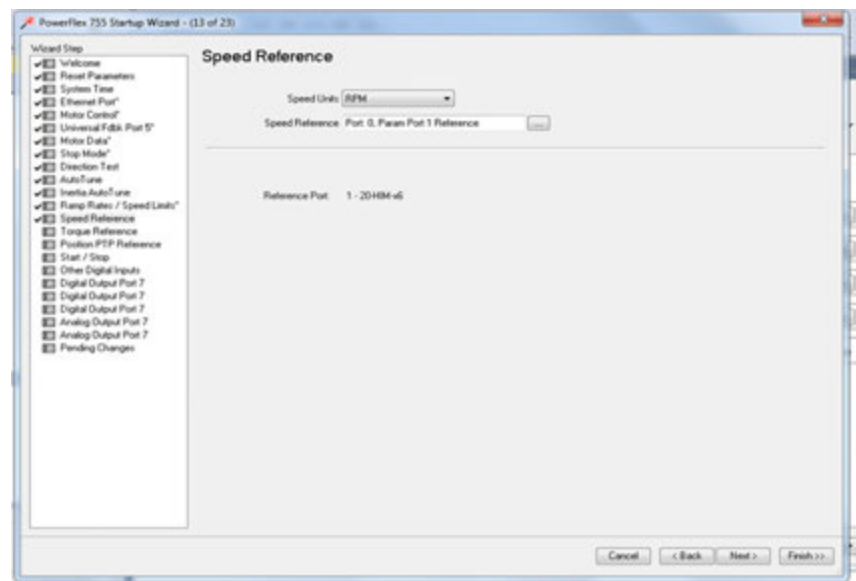

TIP If you want the PLC to control the speed reference, change to the **Port 0: Parameter 13 [EtherNet/IP]**.

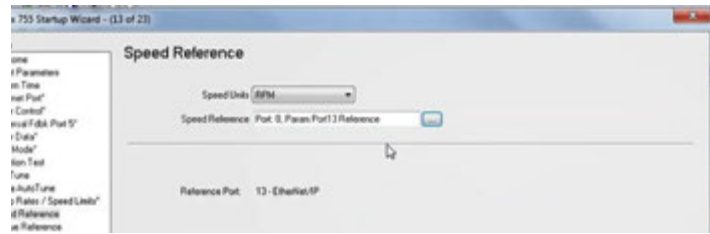

12. Click Next.
13. On the Torque Reference step, leave the values at their defaults for all speed and position-based drives. Click Next.

If your application requires different values, click the ellipsis and use the pull-down menus to select the Port and Parameter for the source of Speed reference for the drive.

For all speed and position-based drives, leave the value at the default value.

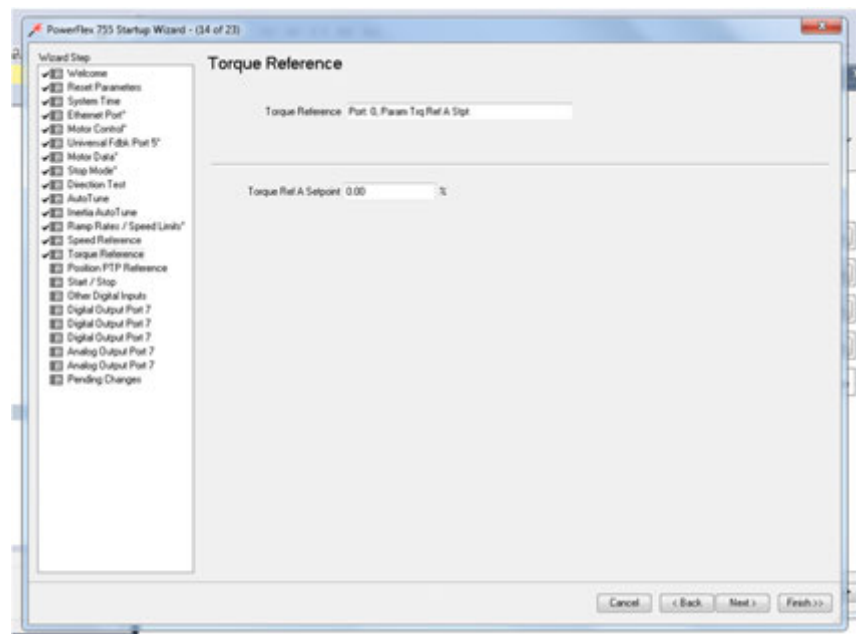

14. If the drive is used as a Position and point-to-point (PTP) regulated drive, set the parameters for the desired performance on the Position PTP Reference step. Click Next.

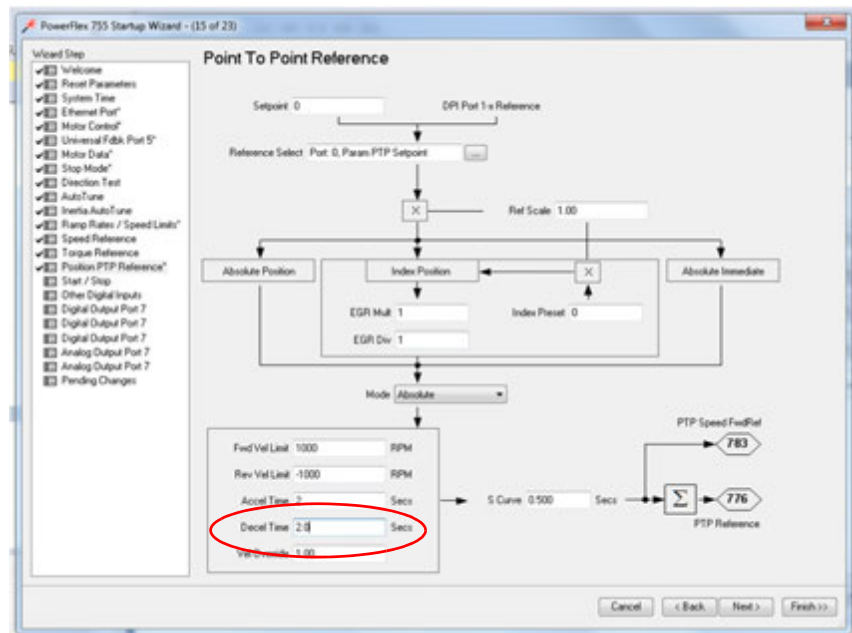

TIP Refer to [Prepare for Initial Drive Start Up](#) for information.

15. On the Start/Stop step, configure the digital input Start/Stop functions if necessary. Click Next.

These do not need to be set if all control actions are coming from the Logix controller. The Logix controller command control word contains start/stop, run/jog, forward/reverse, and so on. These inputs can be used if one of the four I/O points (P0 and P1) on the drive are wired and a desired function must be configured. See the On-Machine electrical schematics.

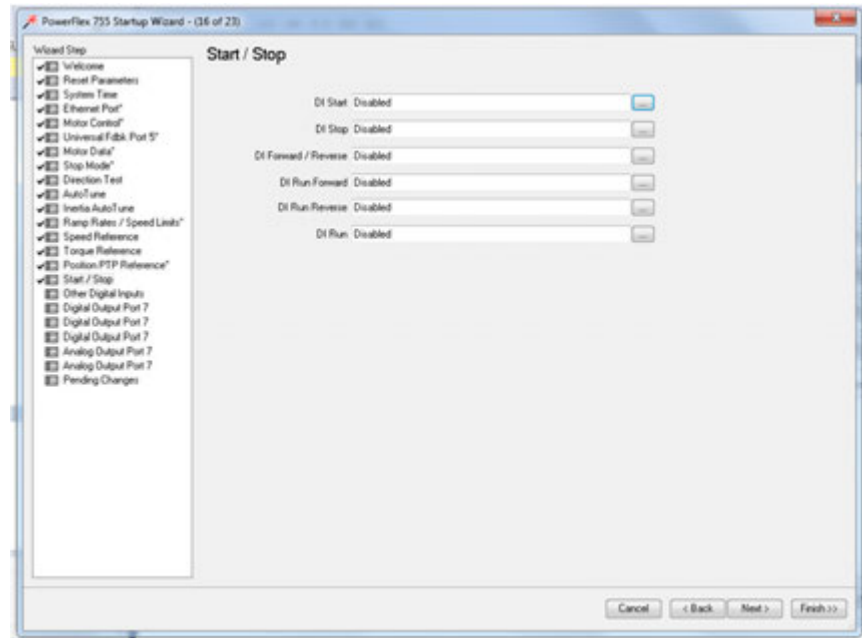

16. On the other Digital Inputs step, you can choose to assign additional digital input functions.

This example shows that the Dynamic brake thermostat is wired to the drive Digital Input 0 on the PowerFlex 755. If desired, assign this input to Enable or Aux. Fault input, as shown, to cause the drive to shut down if this thermostat opens.

If you are assigning this input, it must have a connection that is made with the DBRT receptacle. If you are not assigning this input, you can choose to read its status (via the Logix controller via Datalink out) and then determine what action is taken when it opens. For example: shut down, complete machine index, then shut down, or otherwise. See On-Machine electrical schematics for more information.

IMPORTANT If the signal is open, the drive behavior must be configured for your desired response. Examples of a response include: create an alarm, ignore the action, send a fault code, use a controlled stop, E-stop, and others.

You could also not assign it to this function, but choose to read its status by using the Logix controller via Datalink out, and determine what action to take when it opens. This action could be to shut down, complete machine index, then shut down, and so on. See the On-Machine electrical schematics for more information.

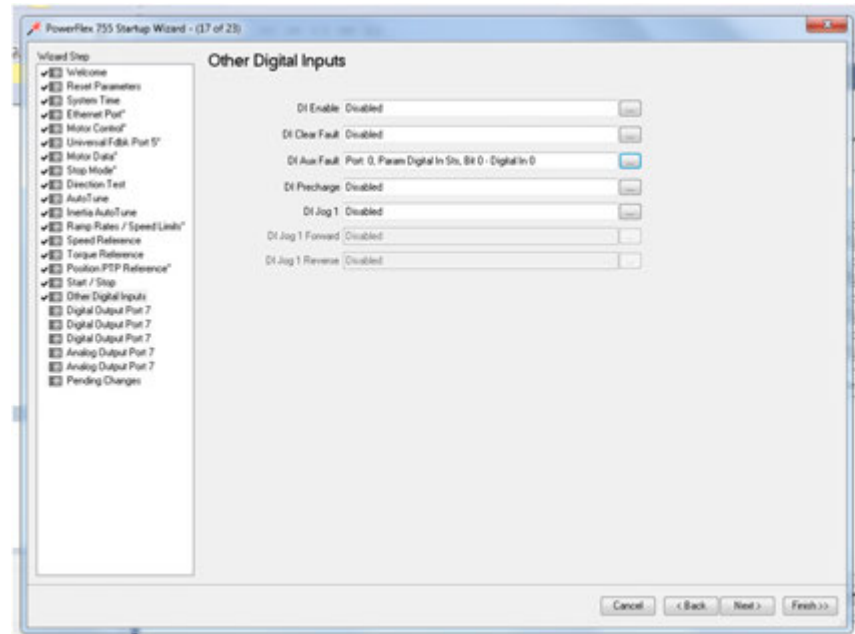

17. Click Next.
18. On the Digital Output steps, click the ellipsis and use the pull-down menus to configure the output.



ATTENTION: Digital Relay out 0 and Transistor Out 0 are both wired to control the motor brake contactor. Their proper configuration is critical for the motor brake control coordination. See the electrical schematics for the brake wiring details. Failure to follow proper wiring will cause a break malfunction and will result in equipment damage.

The electrical schematics show that both the Digital Relay Output 0 and the Transistor Output 0 are wired in parallel to the brake coil. This lets the drive sequence the brake when running, or lets the Logix controller release the brake when not running (typically used during testing).

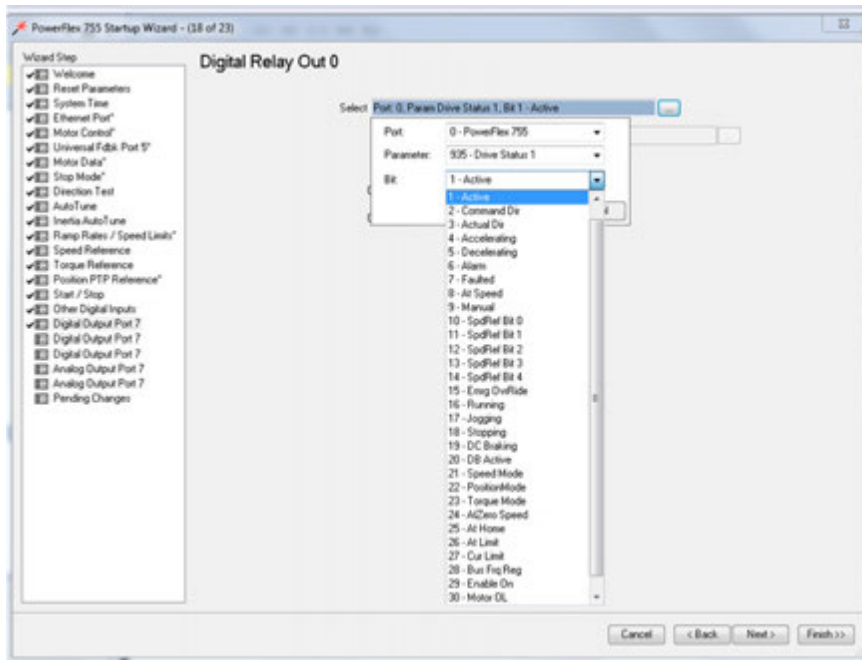
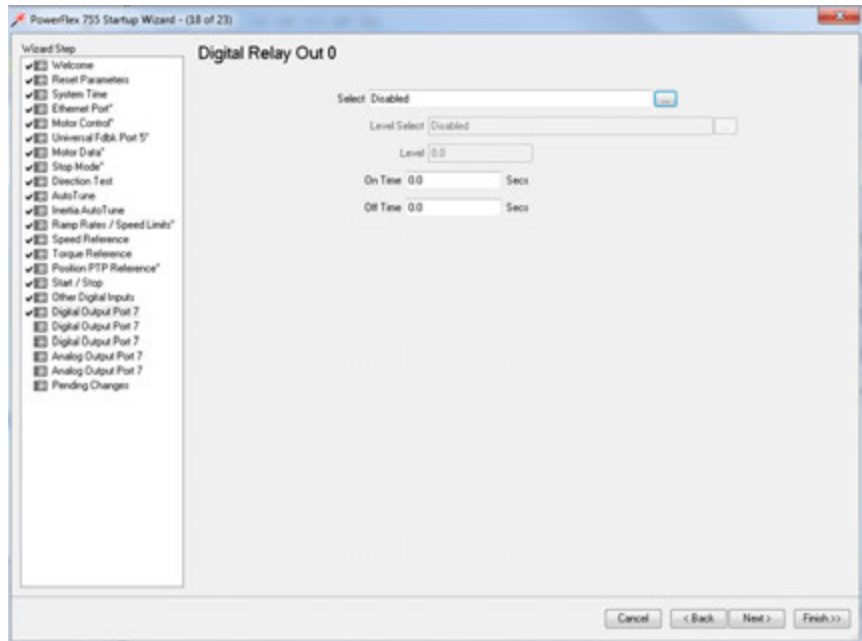

- As a result either output can close the brake contactor, which opens the brake. Configure either the Digital Relay Out 0 or the Digital Transistor Out 0 to release the Motor brake when running the drive.

- Rockwell Automation recommends that you configure the Digital Transistor Out 0 to control the motor brake sequencing from the drive and configure the Digital Relay Out 0 to be controlled by the Logix controller (via Datalink), or leave it unconfigured.

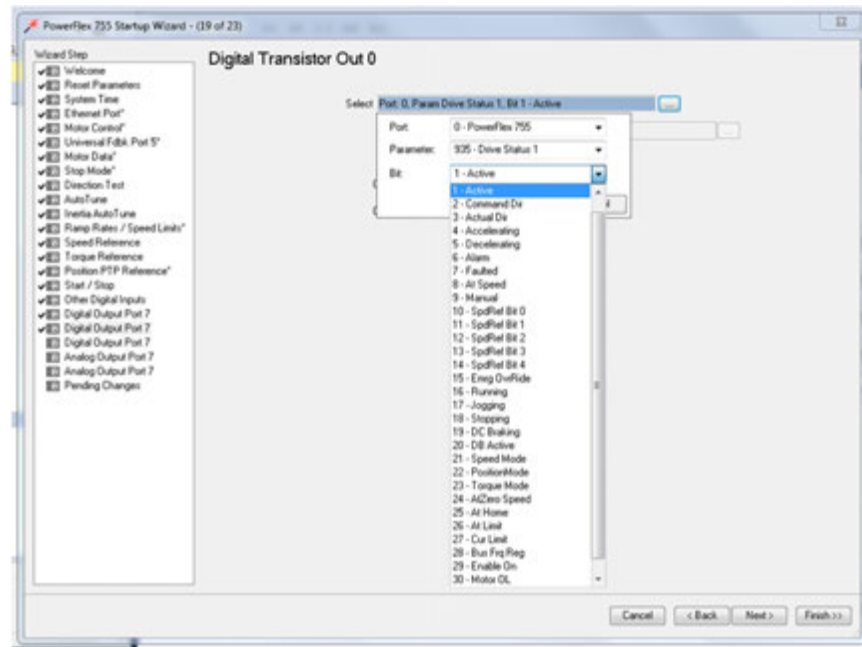

- When selecting **00:935 [Drive Status 1]** bit 1 (Active) is selected in the Digital Output step, the transistor closes anytime the drive is ON, running with its transistors firing. The transistor opens on all other occasions (not running, faulted, power down, and so on). The recommended setting for Digital Transistor Out 0 is shown.
19. Click Next.
 20. Click Next twice to advance to the Pending Changes step, because the drive does not use Analog Output 1 or Analog Output 0. Click Next to advance.

- Review the changes to the drive configuration. Click Finish to return to the Wizards dialog box.

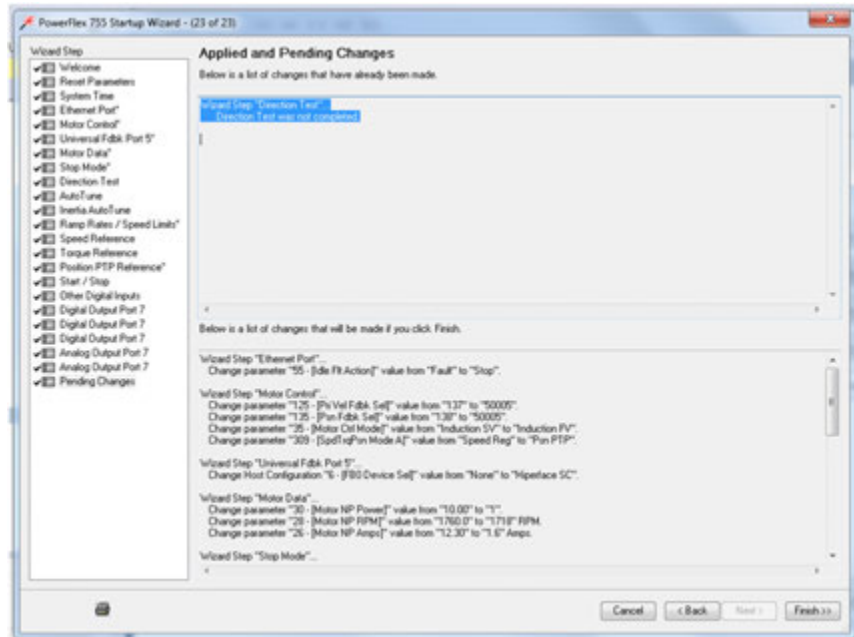

- Click OK to close the Module Properties dialog box.

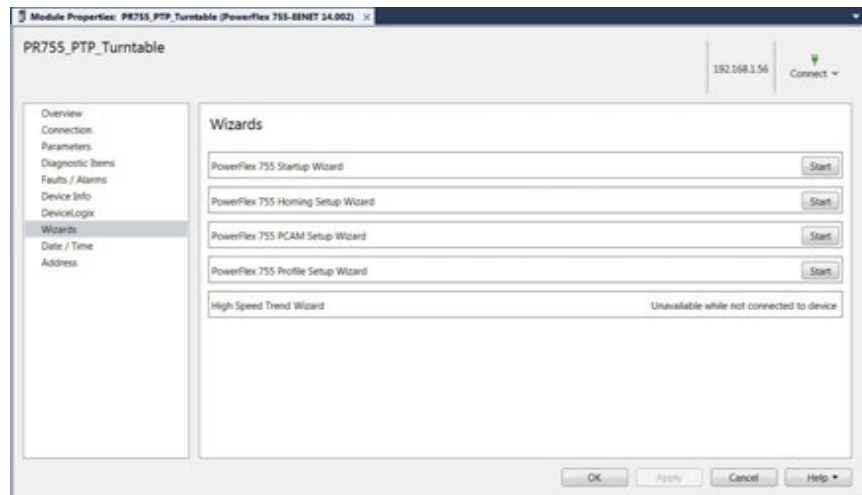

Setup the Datalinks

Follow these steps to set up the datalinks between the drive and the controller.

1. Right-click your drive in the Controller Organizer and select Properties to open the Module Properties dialog box.
2. Click Device Definition.
3. Choose the Connection Format page.
4. Use the pull-down menus to select the drive Input Parameters that you want the Logix Controller to read from the drive.

You can select up to 16 parameters from any port in the drive. Examples include speed, torque, current, position, and so on.

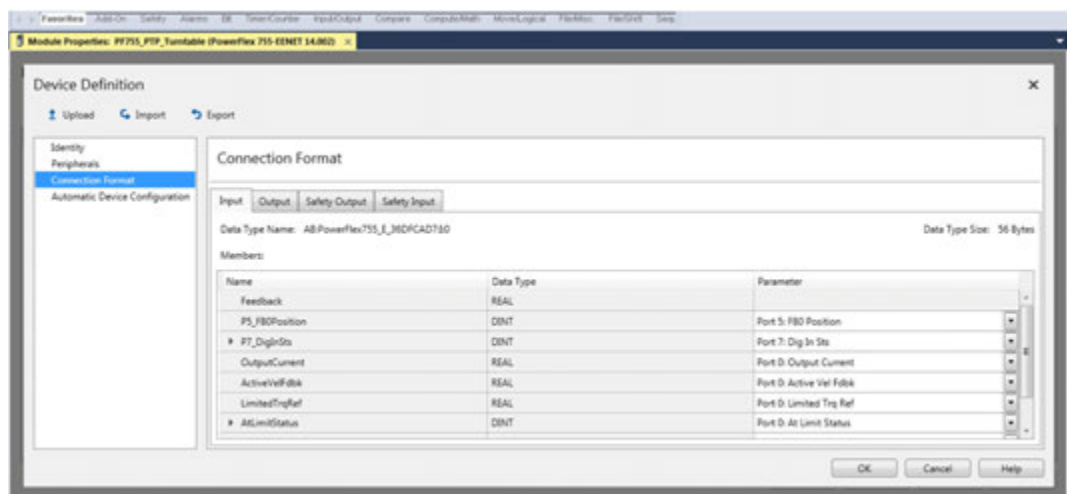

TIP 07:01 [Dig In Sts] should always be assigned and used as one of the Datalinks (to the PAC Network) for remote monitoring of the brake contactor status (Bit 0), circuit breaker status (Bit 1), and the P0 & P1 status (bits 2,3,4,5).

5. On the Output tab, use the pull-down menus to select the drive Output Parameters that the Logix Controller needs to write to the drive.

You can select up to 16 parameters from any port in the drive. Examples: position reference, speeds, Accel/Decel rates, and so on.

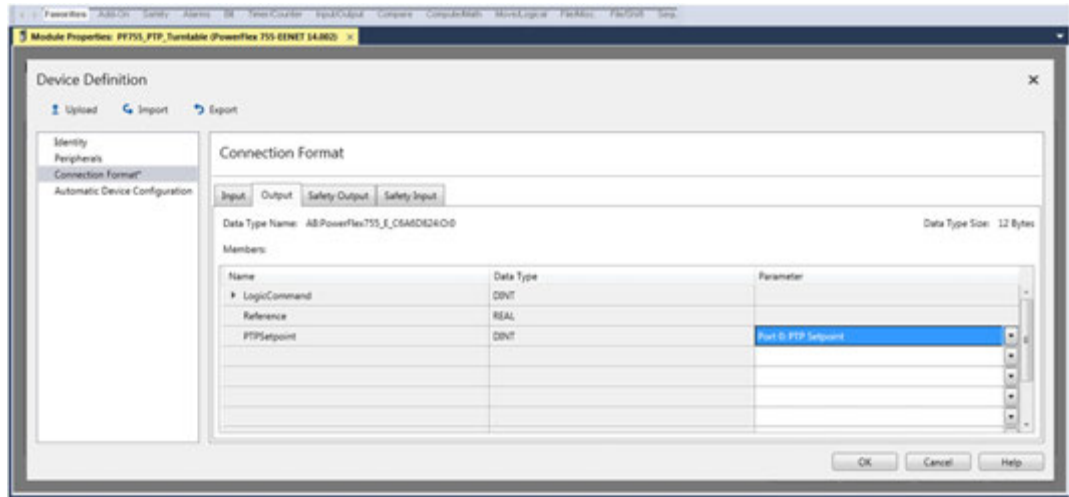

TIP For our SSM and S4 example, the following were chosen:

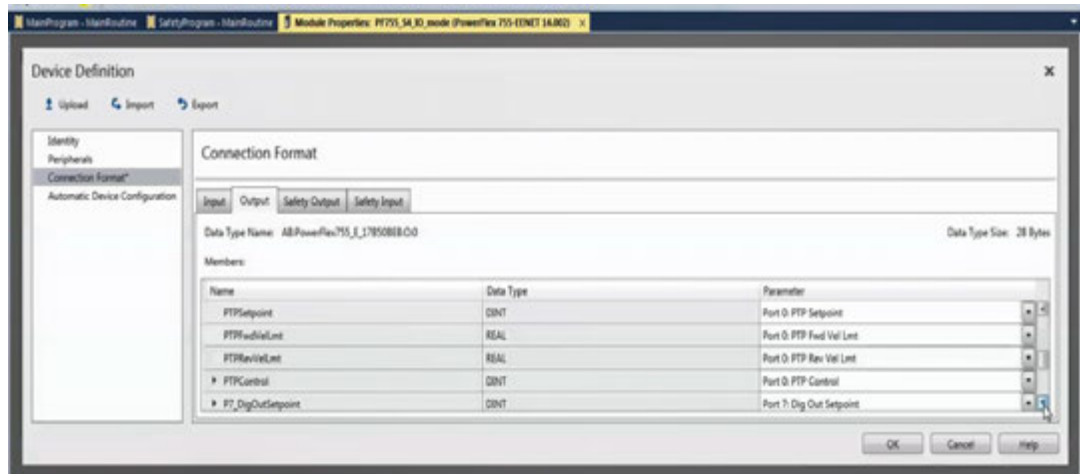

6. After all Inputs and Outputs are defined, click OK.
7. When prompted to confirm changes, click Yes.

Create Safety Logic to Control the Safety Module

The Safe Torque Off function is in the PowerFlex 755 drive and requires safety logic for control. When the connection type is configured as Standard and Safety under the section [Choose Integrated or Hard-wired Safety on page 67](#), the Logix controller generates tags for the safety option module with inputs and outputs that are based on the safety option module that is used by the drive (20-750-S3 or 20-750-S4).

To view the tags, right-click Controller Tags in the Controller Organizer and select Monitor Tags.

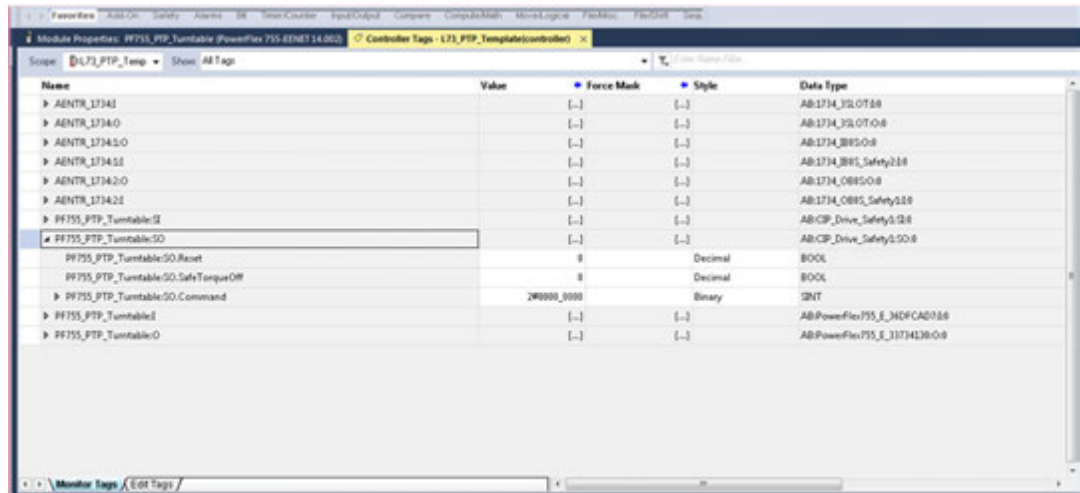

TIP For SSM and S4, from the Controller Organizer, under Safety Task, double-click on 'Main Routine' to view the safety program and ladder logic editor.

In this example, the S3 output tag is PowerFlex 755_PTP_Turntable:SO.SafeTorqueOff is used in a Logix controller safety task to control the Safe Torque Off module in the PowerFlex 755 drive. For SSM and S4 the output is called SO.STO Output

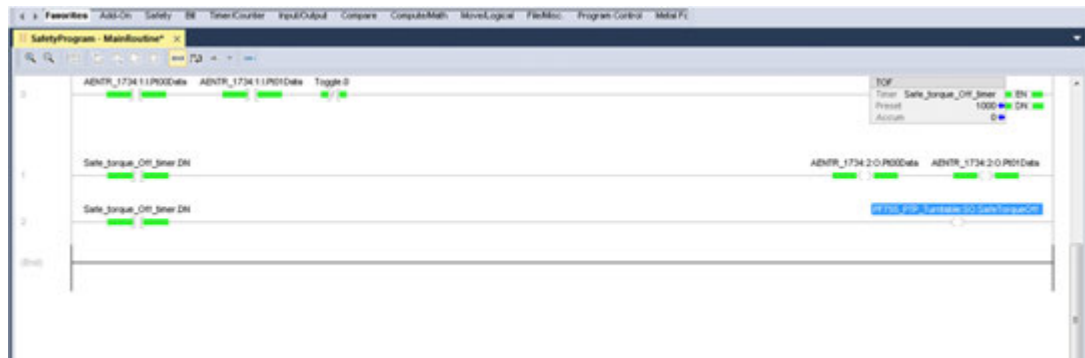

TIP For SSM and S4 use this screen:



IMPORTANT Save your project.

Configure an RS Trend

Configure an RS Trend in the Logix Designer application to trend performance of the system that is controlled by the PowerFlex 755 On-Machine Drive. To create a trend, follow these steps.

1. In the Controller Organizer, right-click Trend and select New Trend.

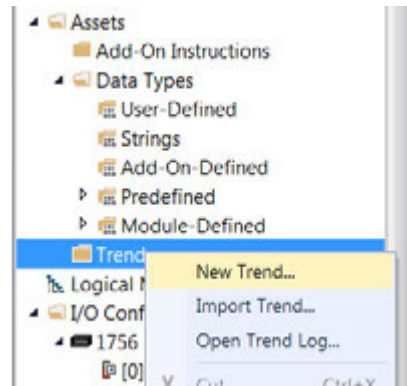

2. Name the trend.

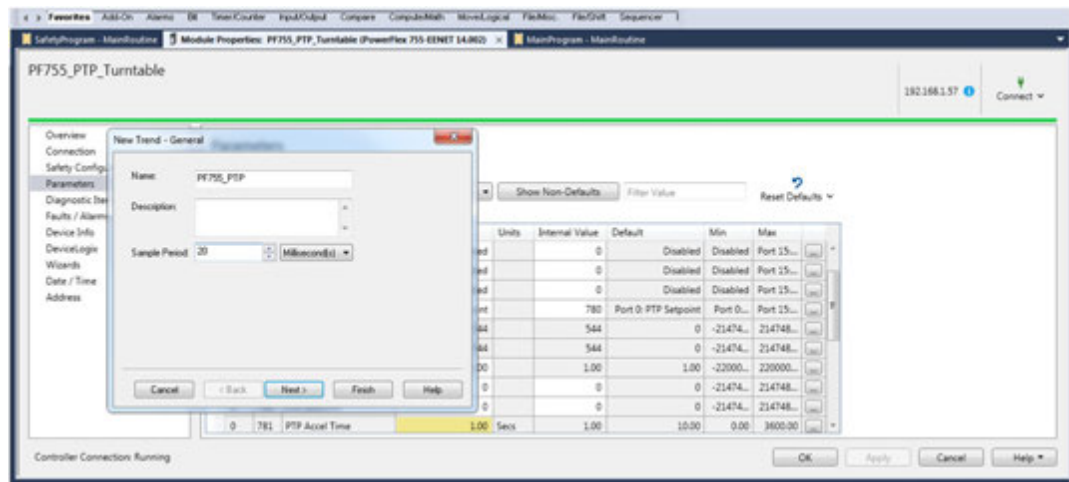

3. Edit the sample time if desired.
4. Click Next.
5. Select the Logix controller tags to observe.

In our example, the selected Logix controller created tags are based on the Datalinks that were configured during commissioning. This example shows a trend that observes the position, speed, torque, current, and position following error of the drive.

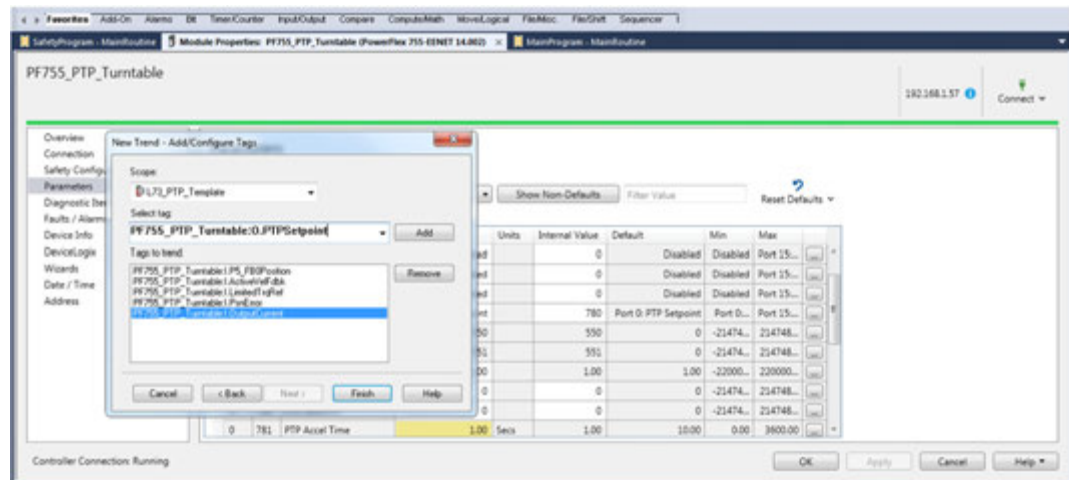

You can use the Trend Properties dialog box to configure the chart pen colors, scaling, and so on. The trend captures the data when online with the Logix Designer application later in this procedure. See [How to Use Trend Settings on page 89](#) for more information on trend configuration.

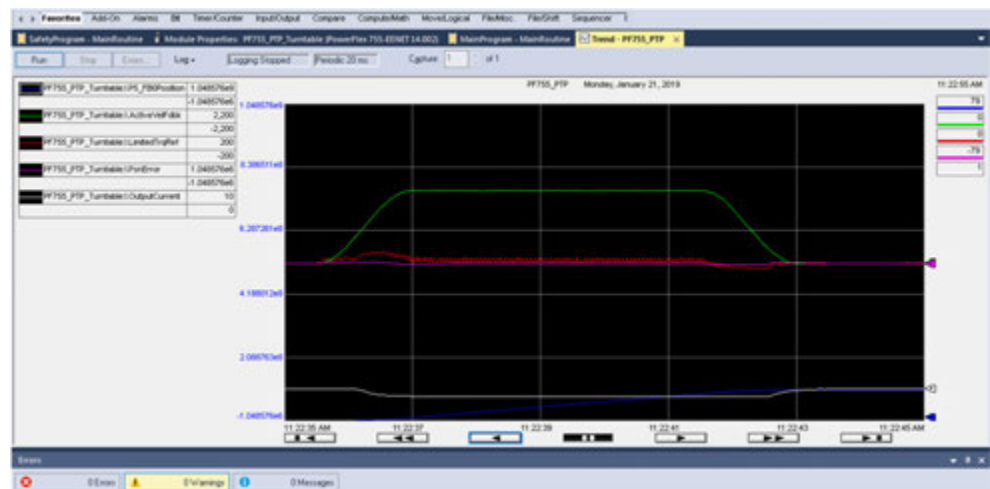

IMPORTANT This example is from an online setup, Trend will not show results until the drive is fully commissioned.

How to Use Trend Settings

1. In the Controller Organizer, right-click your Trend and select Properties to open the properties dialog box. Here you can use the trend properties to configure the chart pen colors, scaling, and so on.

As an alternate option, you can right-click on the chart to access Chart Properties.

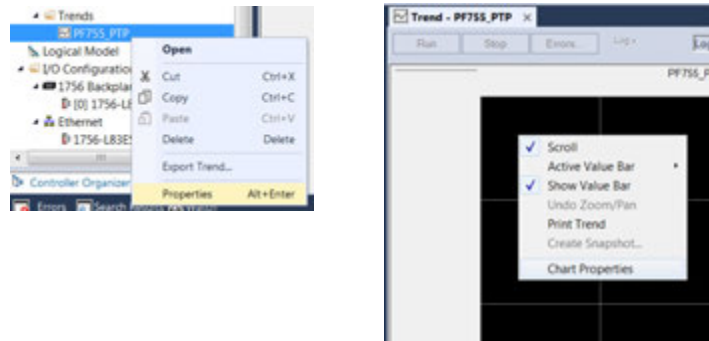

2. After configuration, click Run to start the trend and issue a run or jog command to the PowerFlex 755 from the Logix controller. Trend captures the data. You may save it, delete it, and rerun it to observe the machine performance.

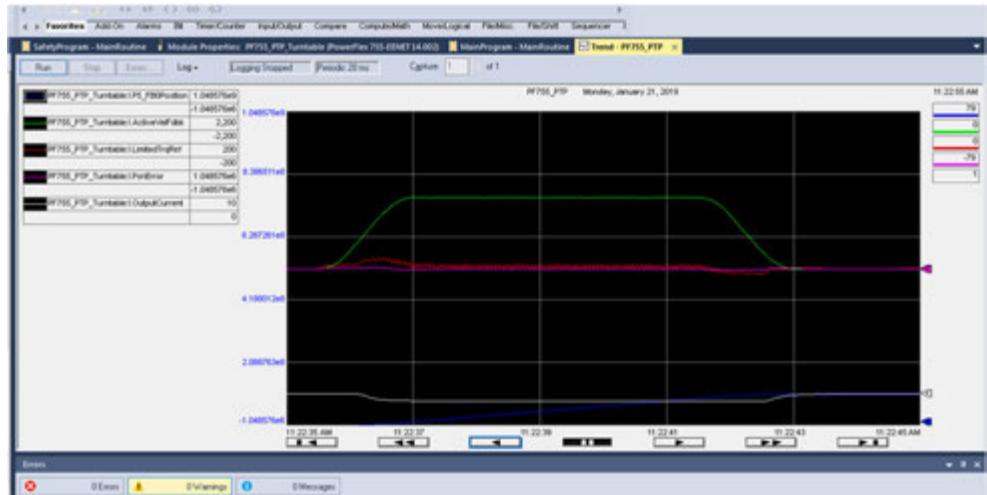

3. Right-click in the graph to add line bars, delta bars, and more to help evaluate the system performance.

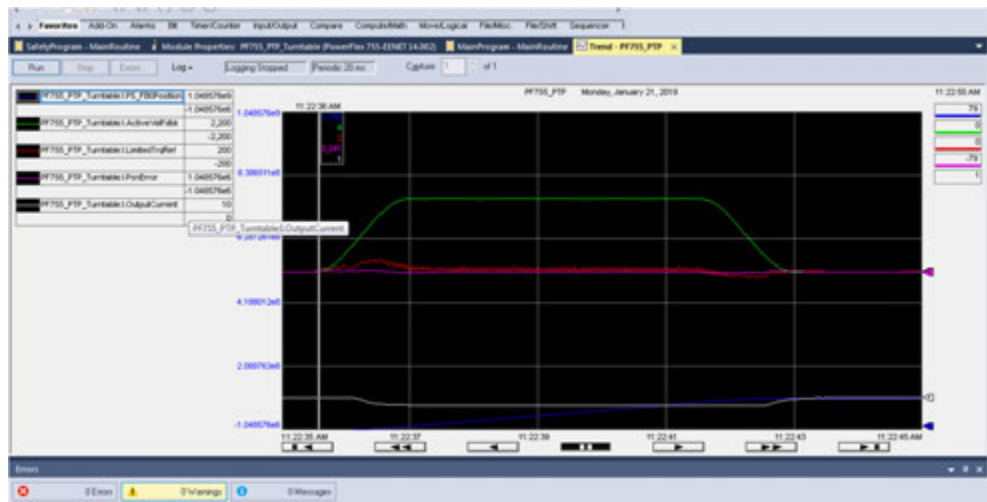

A view of the delta tab is shown by the two white vertical lines that display the difference in the values of these two times.

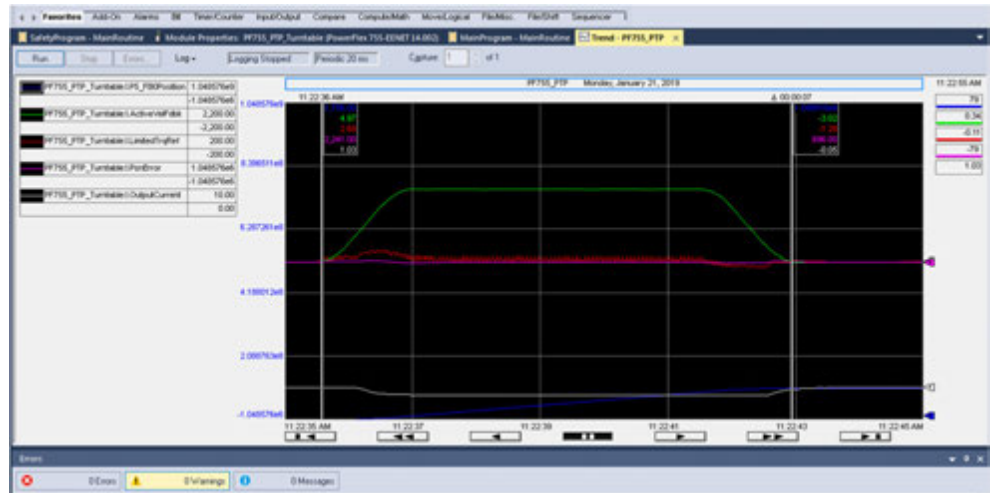

4. After creating a trend, click Log on the Trend Control Bar to save the file if desired.

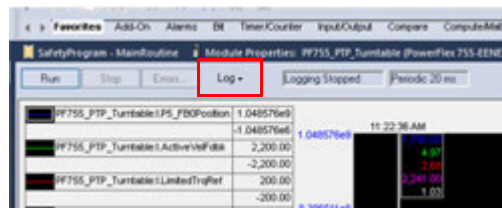

5. If you save the Logix Designer application project after creating a trend (online instead of in the original configuration), and the following message occurs, click Yes and the trend saves in the project so it can be reused any time.

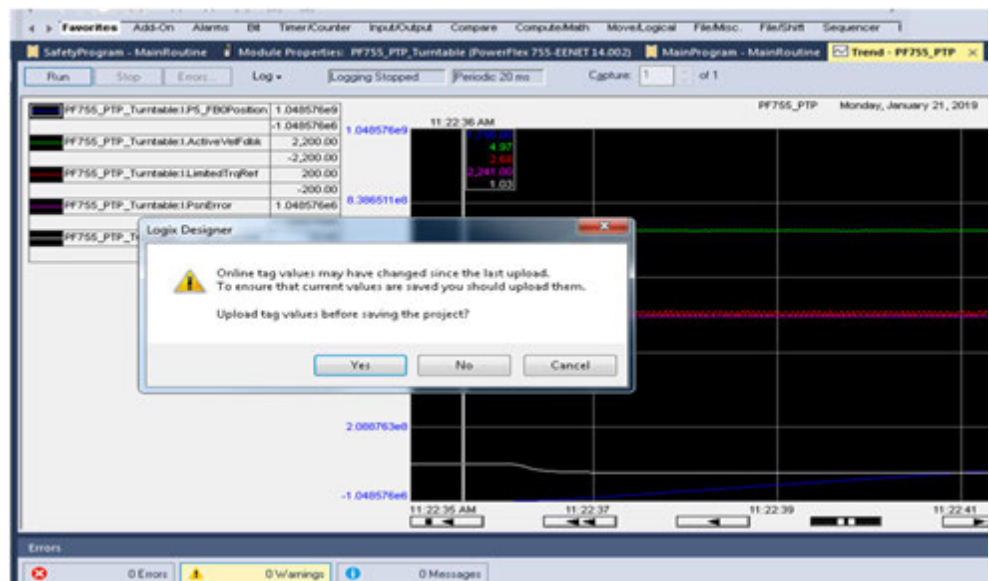

Save and Download Project

TIP Make sure the laptop IP address is on the same subnet IP before continuing with Save and Download Project.

1. After the drive is configured and the ladder logic is written, save your Logix Designer application project.
2. From the Communications menu, select Who's Active to load the program to your Logix controller.

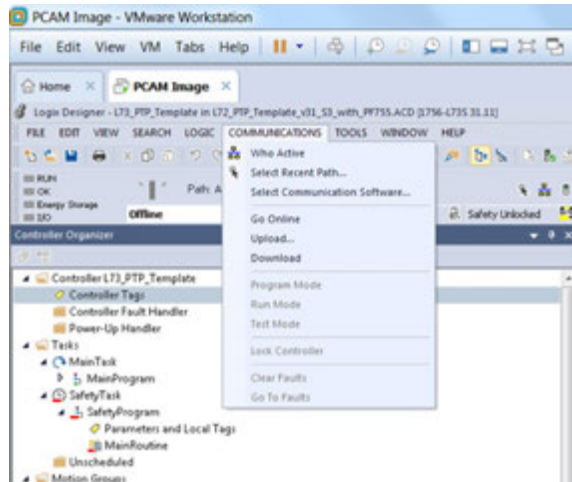

3. From the Who's Active dialog box, choose your controller, then select Download.
4. When the Download dialog box appears, click Download to complete the loading of the program into the Logix controller.

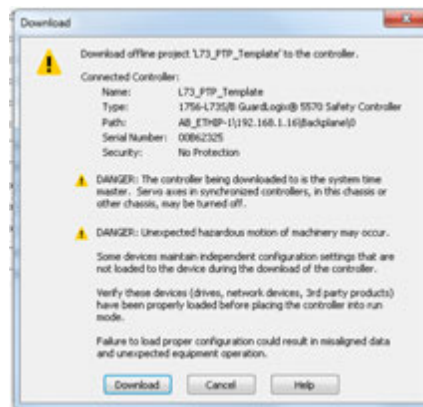

Go Online with the Logix Controller

After the program is downloaded, keep the Logix controller in Program mode to load the drive parameters into the PowerFlex 755 drive. If a yellow triangle appears next to the EtherNet/IP network entry, it indicates an issue with that device. This is likely because the project drive parameters and I/O configurations do not match the online PowerFlex 755 On-Machine Drive configuration.

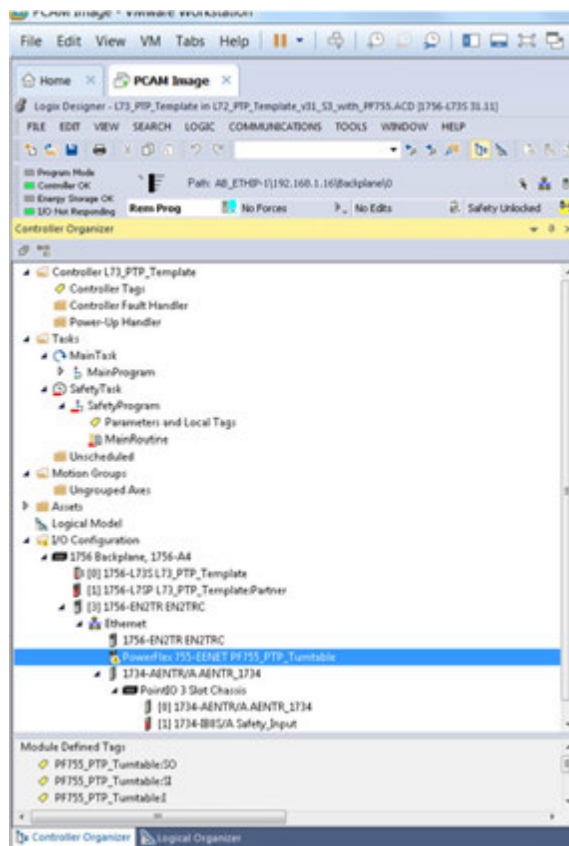

1. Right-click on the PowerFlex 755 drive in the Controller Organizer and select Properties to open the Module Properties dialog box.

The project tries to connect to the drive at the defined EtherNet/IP address.

Because the original startup for the drive is conducted offline, there is a mismatch of information between the project and the physical drive.

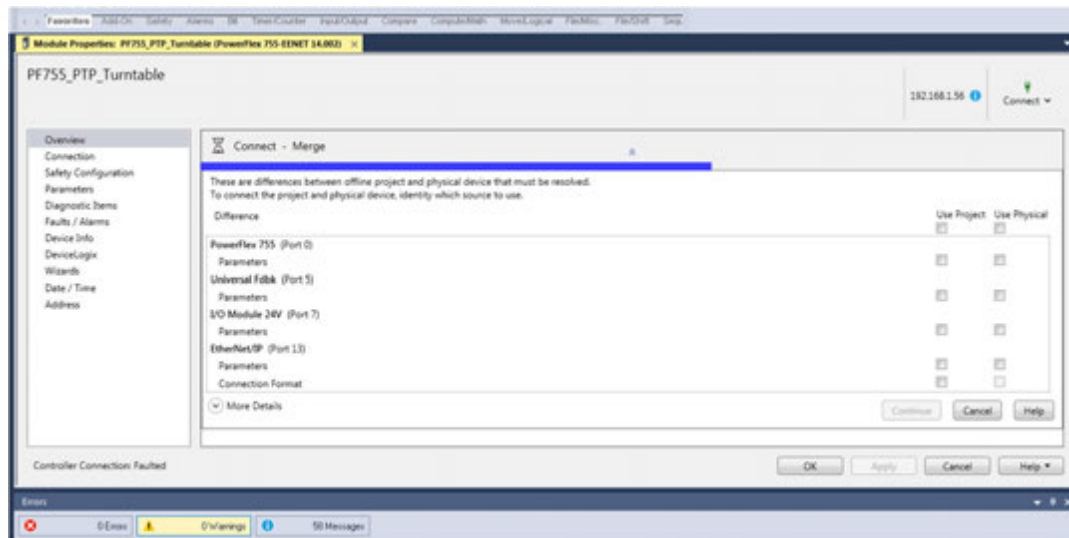

2. Check Use Project for all applicable items. Click Continue.

The Logix Designer application loads the drive parameters from the project to the drive.

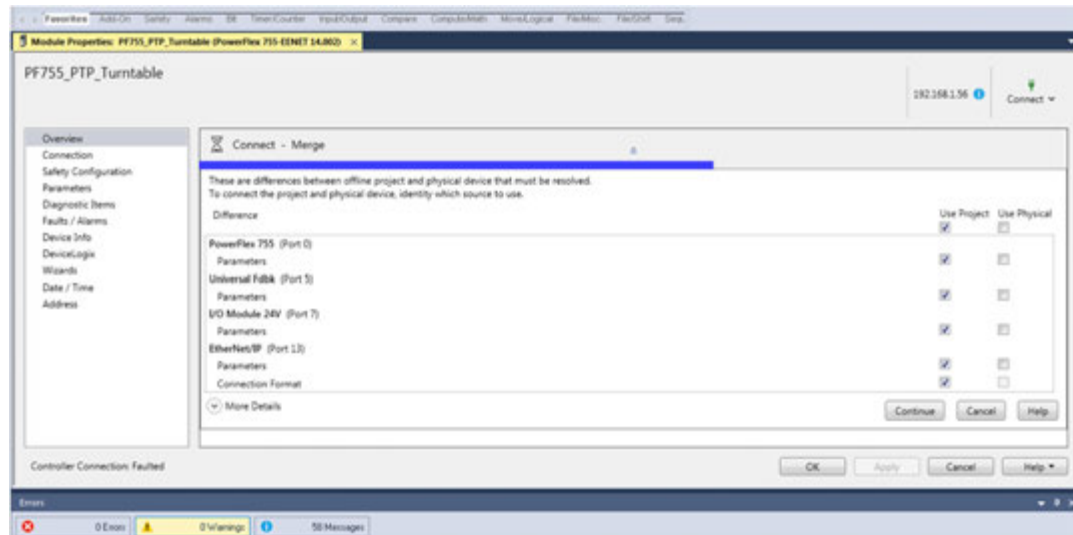

3. When notified that a reset is required, Click OK.

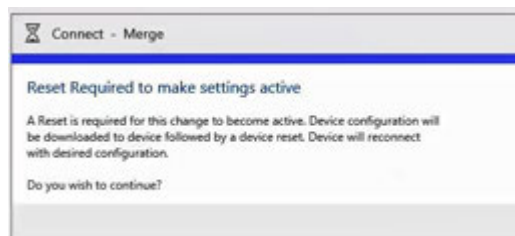

TIP If you receive a connection error, click Retry. When this error occurs, you are required to repeat steps 1...3 of this section. If the problem continues after a couple of attempts, go to the [Troubleshooting](#) chapter.

After the parameters have loaded, the view changes back the Overview Dialog box. Notice in the example, that the yellow triangle has disappeared.

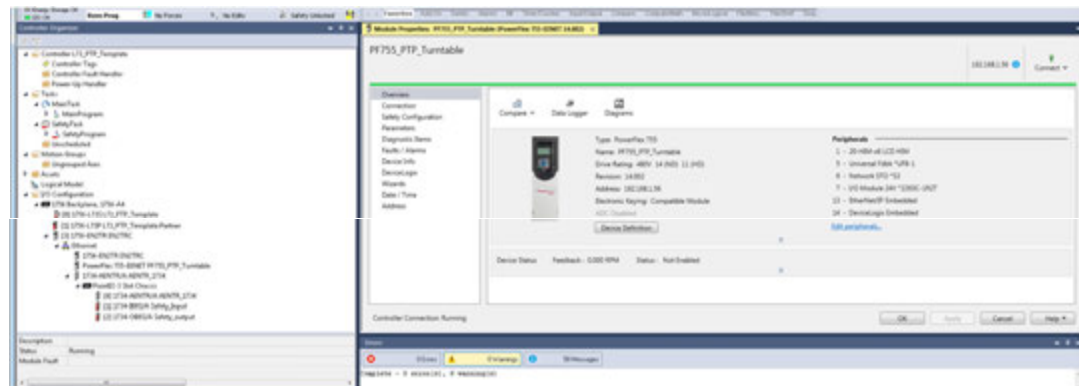

TIP If the drive does not come online, see [Troubleshooting Going Online on page 185](#) in the [Troubleshooting](#) chapter of this manual.

Put the Logix Controller Into Run Mode

1. Use the Controller Status pull-down menu to put the Logix controller into Run mode.

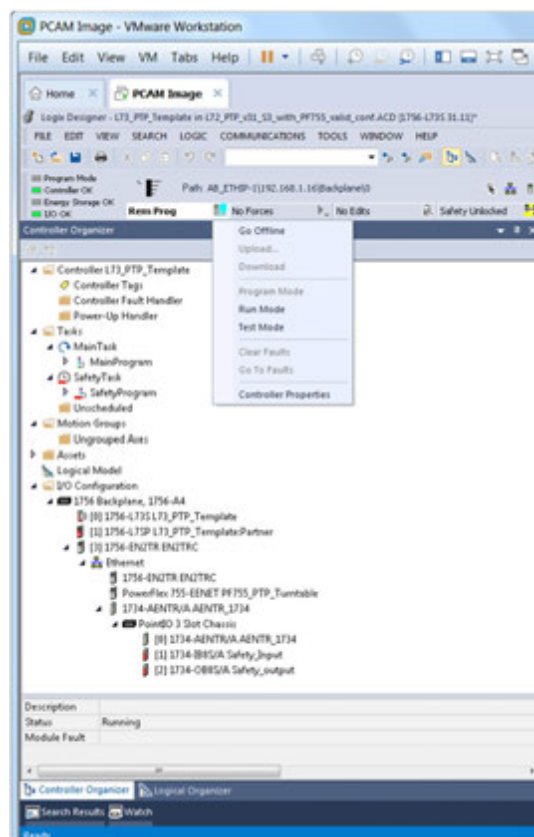

2. Click Yes when prompted to change controller mode to Remote Run.

Turn Safety On (SSM and S4 Only)

1. In the Controller Organizer, under the heading Safety Task, double-click on Main Routine.
2. When the Safety Ladder logic opens, select the status words to change the status from Off to On.

When this is complete, the safety enable in the drive is on and active and is ready to continue with setup.

For additional information on configuring the SSM or S4 option module, refer to PowerFlex 755/755T Integrated Safety Functions Option Module (S4), publication [750-UM005](#).

Energize the Incoming Power and Brake Circuit Breakers

After you have completed the configuration of the drive, energize the main incoming 400/480V AC and the brake circuit breakers. See [Apply Power on page 170](#) for more information.

1. Use the cover-mounted HIM, CCW, Drive Executive, or Logix Designer application to monitor **00:11 [DC Bus Volt]**.
 - With the main input energized, the voltage should be 515V DC (with 400V AC input)...650V DC (with 480V AC input).
 - If circuit breakers 1 and 2 are both energized properly, **07:01 [Dig In Sts] bit 1 = 1**. If **07:01** bit 1 equals 0, the circuit breakers are tripped.

If the voltage is outside of this range, go upstream to the power distribution system and verify that the 3-phase power is being provided to the drive.



ATTENTION: Equipment damage could occur if you try to operate without proper power. Do not proceed to the next step until proper 3-phase power and brake power are provided to the PowerFlex 755 On-Machine Drive.

2. With incoming, brake, and control power energized and verified, open the controller safety program in the Logix Designer application, and enable the Safe Torque Off bit of the PowerFlex drive.

In our example, PowerFlex 755_PTP_Turntable:SO. SafeTorqueOff is shown energized which enables the safety circuits in the PowerFlex 755.

3. With safety energized, the HIM display should change from Not Enabled to Stopped.

IMPORTANT Safety must be energized and all faults in the drive cleared before any additional commissioning can be done.

If the HIM shows a fault, the fault must be reset before you can proceed to the next step. See [Fault Types, Descriptions, and Actions on page 174](#) in the [Troubleshooting](#) chapter of this manual.

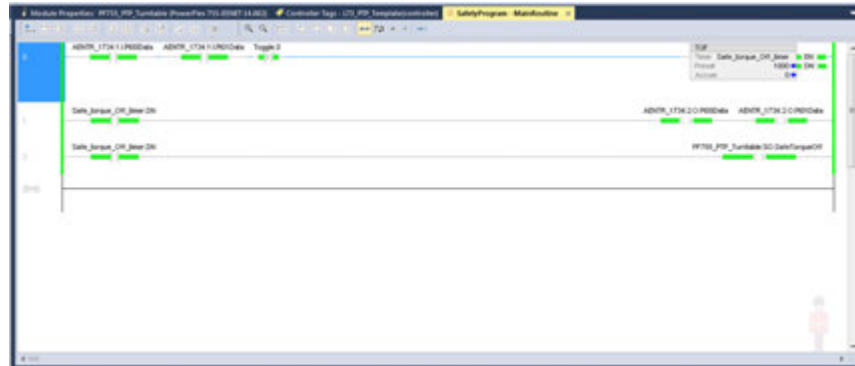

Perform Motor Auto Tune Tests

The next steps in the startup process verify encoder and motor direction configurations and perform a Motor Autotune, Inertia Tune, and confirm proper Direction Verification. You have to perform these tests by using methods described in this section, because these tests are disabled in the Startup Wizard when the drive is controlled by a Logix controller.

For more information on tuning, refer to PowerFlex 700S and PowerFlex 755 Drives Tuning, publication [750-AT004](#) and PowerFlex 750-Series AC Drives Quick Start, publication [750-QS001](#).

Autotune/Static Tune

The Autotune test identifies the correct motor flux and stator electrical properties, including:

- IR volt drop, which is voltage drop over resistance.
- Ixo volt drop, which is voltage drop over inductance.
- Flux current (estimated in Static Tune and measured during Rotate Tune test).
- Slip RPM, which is calculated from motor nameplate data. If an encoder is used, the Slip RPM becomes a measured value using the encoder.

A properly tested motor and drive helps deliver higher starting torque and better performance at low speeds. Conversely, an improperly performed Rotate Tune can cause the motor to exhibit instability at low speeds, uneven performance when running through the motor speed range, and can generate unnecessary faults such as overcurrent and overvoltage faults.

1. Choose the Parameters page from the Module Properties dialog box and select **0 - PowerFlex 755**.

2. Select **Feedback** in the center pull-down menu to show the parameters in this section of the drive.

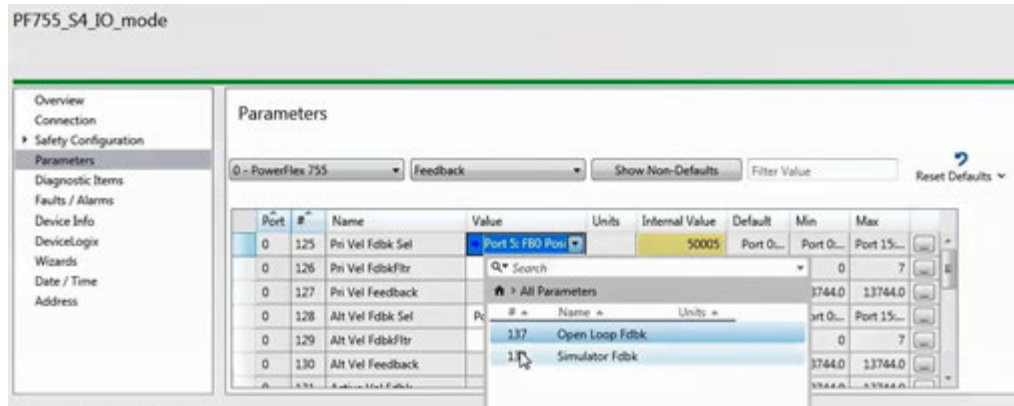

TIP Encoder feedback must be temporarily disabled in order to complete the motor autotune tests and inertia tune.

In our example the universal feedback card is in port 5.

- **00:125 [Pri Vel Fdbk Sel]** has been chosen to provide primary velocity feedback to the drive. The value used was **05:137 [Open Loop Fdbk]**.

TIP Record the values in [step 2](#), you will revert to these values after completing the Direction Verification.

- **00:128 [Alt Vel Fdbk Sel]** has also been chosen to provide alternate velocity feedback and display the speed. The value used was **05:05 [FBO Position]**.

3. In the Value column, choose **05:05 [FBO Position]** to pull the information from the Universal Feedback device.

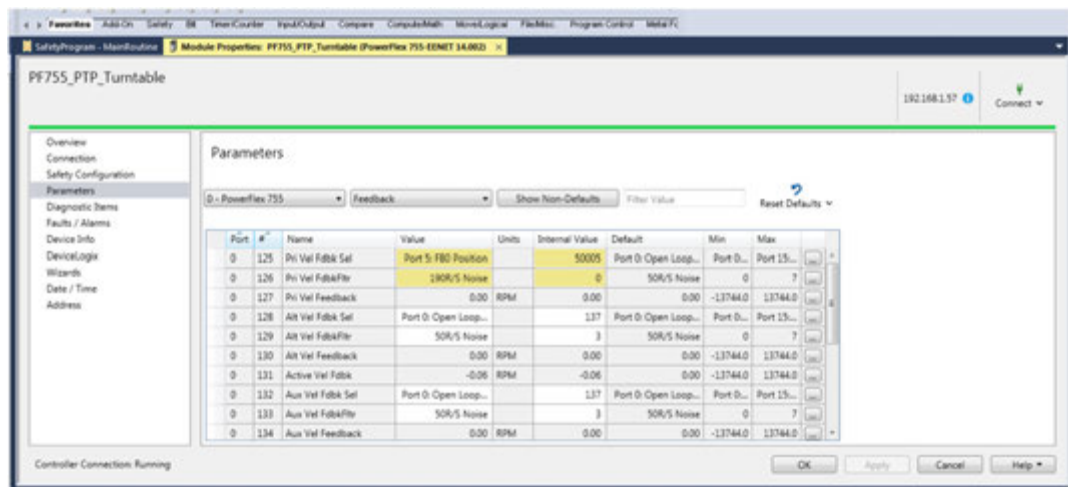

4. Change 00:125 [Pri Vel Fdbk Sel] to 00:137 [Open Loop Fdbk].

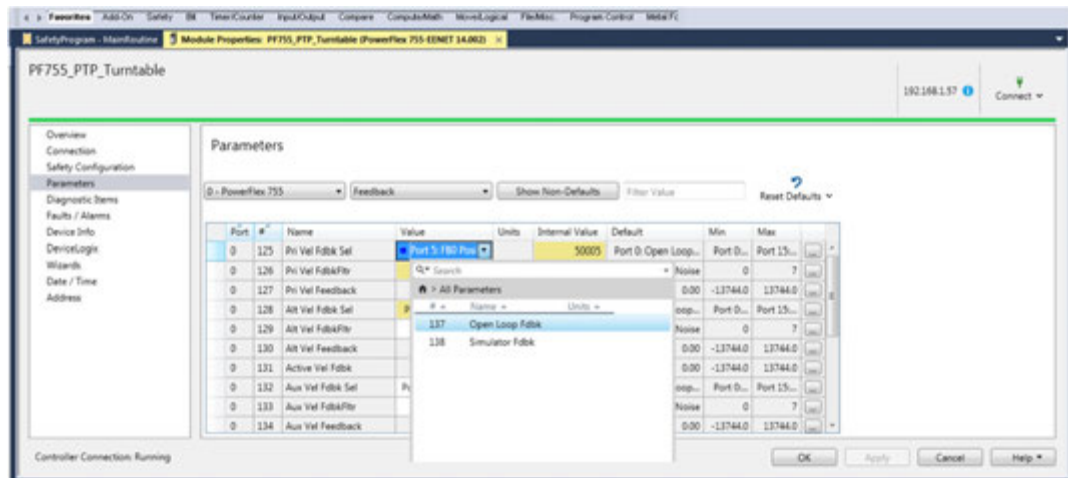

5. Change 00:128 [Alt Vel Fdbk Sel] to 05:05 [FB0 Position], to observe the encoder velocity and direction when the motor is jogged.

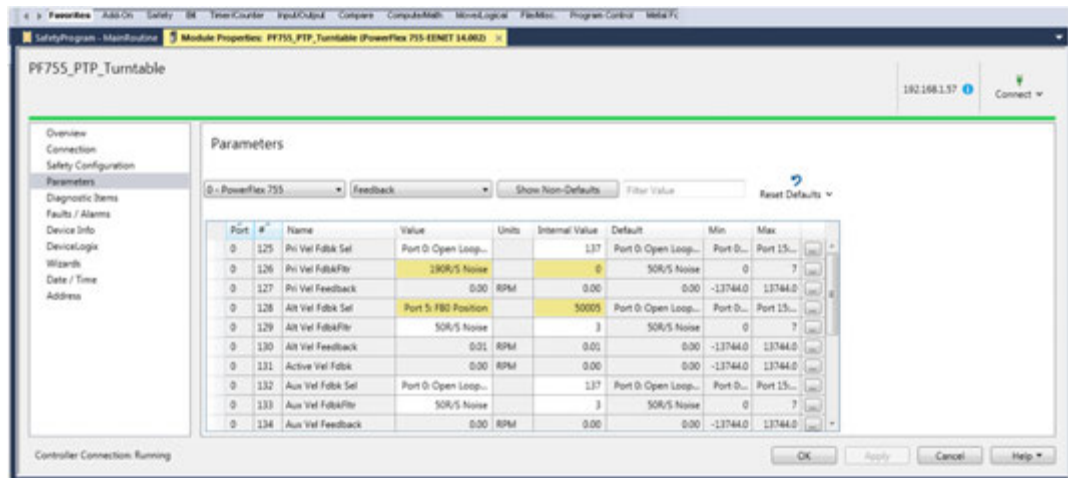

6. On the Parameters page, change the Parameter selection to 0-PowerFlex 755 Motor Control | Autotune | Show Non-Defaults.

The following is displayed:

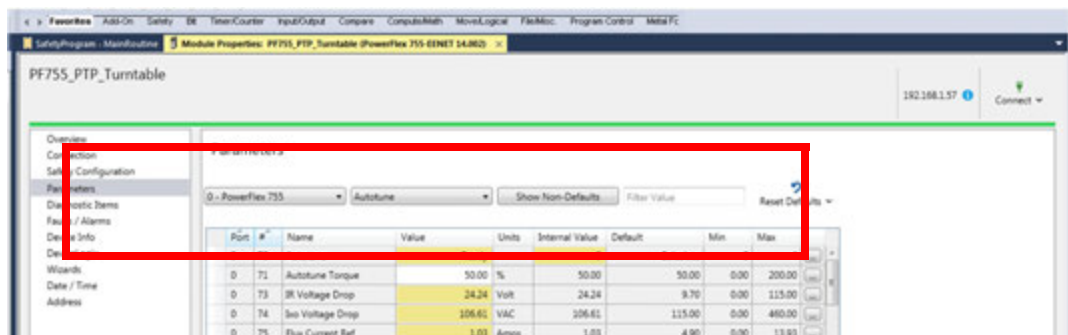

7. Change 00:70 [Autotune] from Ready (0) to Static Tune (2).

Use **00:70 [Autotune]** to conduct a Static Tune (2) or Rotate Tune (3) and an Inertia Tune (4). The parameter **00:70 [Autotune]** description is shown for more information.

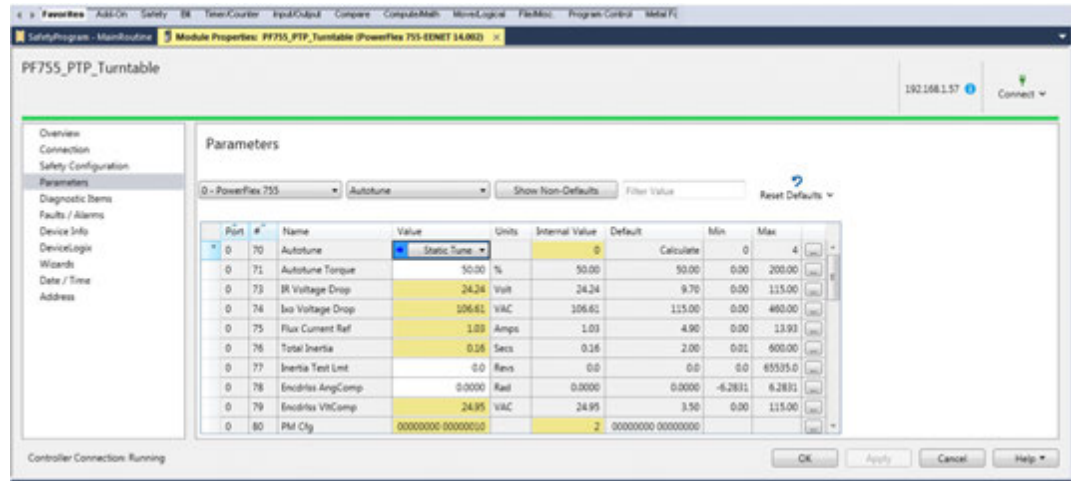

70



Autotune

Provides a manual or automatic method for setting P73 [IR Voltage Drop], P74 [Ixo Voltage Drop] and P75 [Flux Current Ref]. Valid only when parameter P35 [Motor Ctrl Mode] is set to 1 Induction SV, 2 Induct Econ, or 3 Induction FV.

Ready (0) – Parameter returns to this setting following a Static Tune or Rotate Tune, at which time another start transition is required to operate the drive in normal mode. It also permits manually setting P73 [IR Voltage Drop], P74 [Ixo Voltage Drop] and P75 [Flux Current Ref].

Calculate (1) – Uses motor nameplate data to automatically set P73 [IR Voltage Drop], P74 [Ixo Voltage Drop], P75 [Flux Current Ref] and P621 [Slip RPM at FLA].

Static Tune (2) – A temporary command that initiates a non-rotational motor stator resistance test for the best possible automatic setting of P73 [IR Voltage Drop] in all valid modes and a non-rotational motor leakage inductance test for the best possible automatic setting of P74 [Ixo Voltage Drop] in a Flux Vector (FV) mode. A start command is required following initiation of this setting. Used when motor cannot be rotated.

Rotate Tune (3) – A temporary command that initiates a Static Tune followed by a rotational test for the best possible automatic setting of P75 [Flux Current Ref]. In Flux Vector (FV) mode, with encoder feedback, a test for the best possible automatic setting of P621 [Slip RPM at FLA] is also run. A start command is required following initiation of this setting. **Important:** If using rotate tune for a Sensorless Vector (SV) mode, the motor should be uncoupled from the load or results may not be valid. With a Flux Vector (FV) mode, either a coupled or uncoupled load will produce valid results.



ATTENTION: Rotation of the motor in an undesired direction can occur during this procedure. To guard against possible injury and/or equipment damage, it is recommended that the motor be disconnected from the load before proceeding.

Inertia Tune (4) – A temporary command that initiates an inertia test of the motor/load combination. The motor will ramp up and down while the drive measures the amount of inertia. This option only applies to FV modes selected in P35 [Motor Ctrl Mode]. Final test results should be obtained with the load coupled to the motor.

8. With **00:70 [Autotune]** reading Static Tune (2), it conducts this test the next time the drive is told to run or jog.
9. Initiate a Start command. Start can be commanded via the HIM or from the Logix controller ladder logic.



ATTENTION: This procedure causes movement of the motor shaft and of any connected equipment. To guard against personal injury or damage to equipment, verify that all guards are properly installed to help protect against contact with rotating parts.

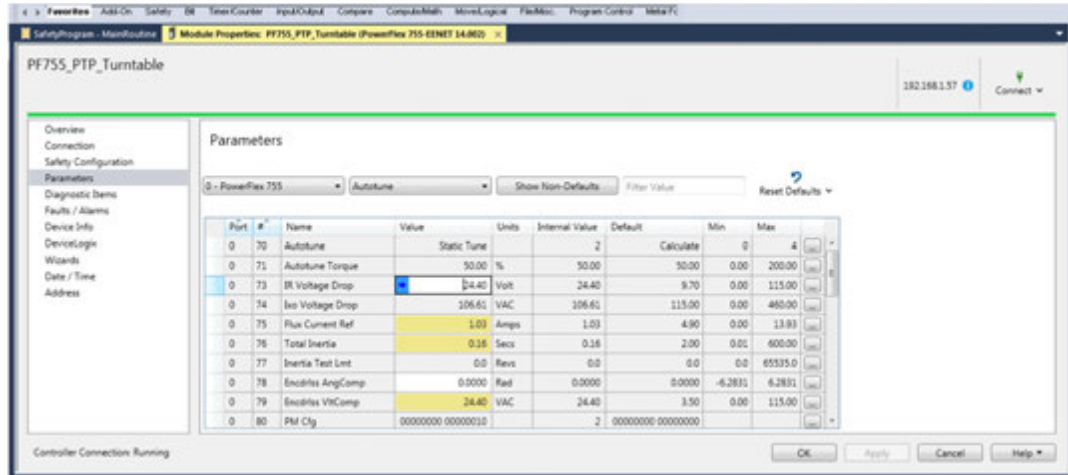

- After the Static Tune (2) completes, **00:70 [Autotune]** changes back to Ready (0), and **00:71 [Autotune Torque]**, **00:73 [IR Voltage Drop]**, and **00:74 [Ixo Voltage Drop]** are update based on the motor electrical design.

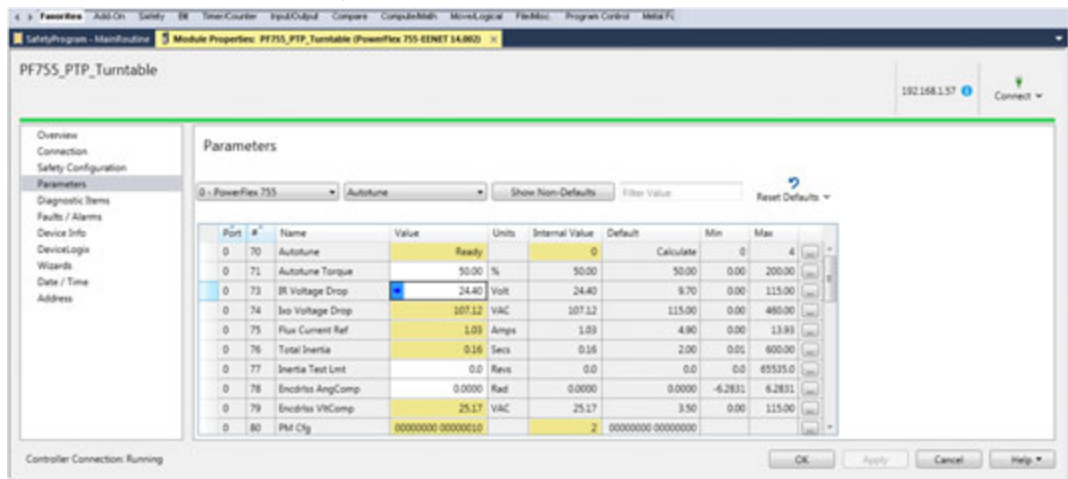

Rotate Tune

If the Motor is uncoupled, perform a Rotate Tune by using the procedure in [Autotune/Static Tune on page 97](#). The screens show how to configure the test for Rotate Tune. This test is used when the motor is not coupled to the load, or the load is low friction. Rotate Tune is used to better identify motor flux and stator electrical properties, which are used to automatically tune the torque/ current loop.

The Rotate Tune test causes motor rotation at different speeds while it is executing. Set **00:70 [Autotune]** to Rotate Tune (3). See [step 7 on page 99](#) for more information



ATTENTION: If the drive was never operated before (new installation), verify that safeguards are in place to remove power safely from the drive during an unstable situation where the drive can produce undesired motion.

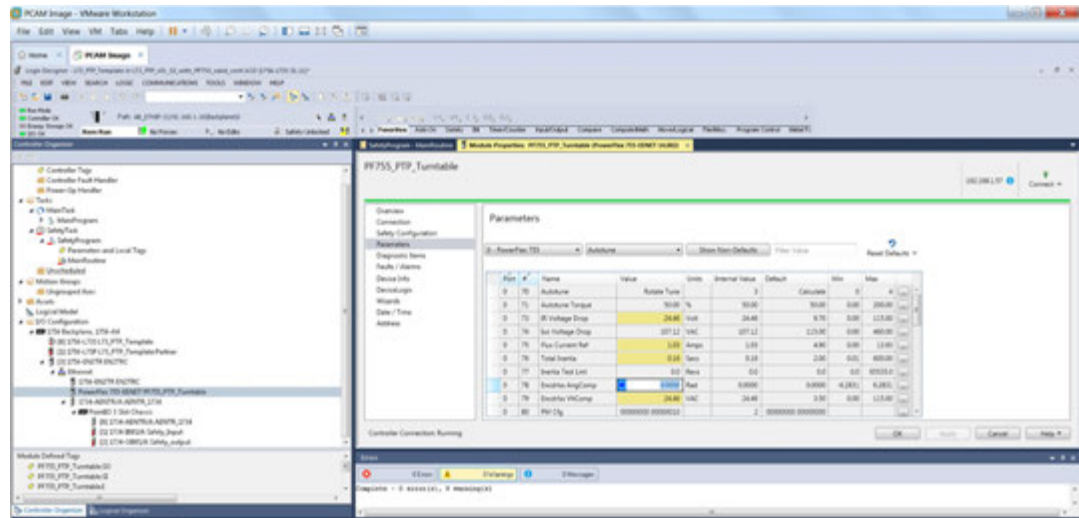

Inertia Tune

After the Autotune and Rotate Tune are complete, perform an Inertia Tune. The motor should be uncoupled. During the test, the drive/motor is accelerated using the entered Autotune Torque value. The time required to accelerate the motor and load from zero speed to rated speed is measured.

The Inertia Tune test causes motor rotation at different speeds while it is executing. Set **00:70 [Autotune]** to Inertia Tune (4). See [step 7 on page 99](#) for more information.



ATTENTION: If the drive was never operated before (new installation), verify that safeguards are in place to remove power safely from the drive during an unstable situation where the drive can produce undesired motion.

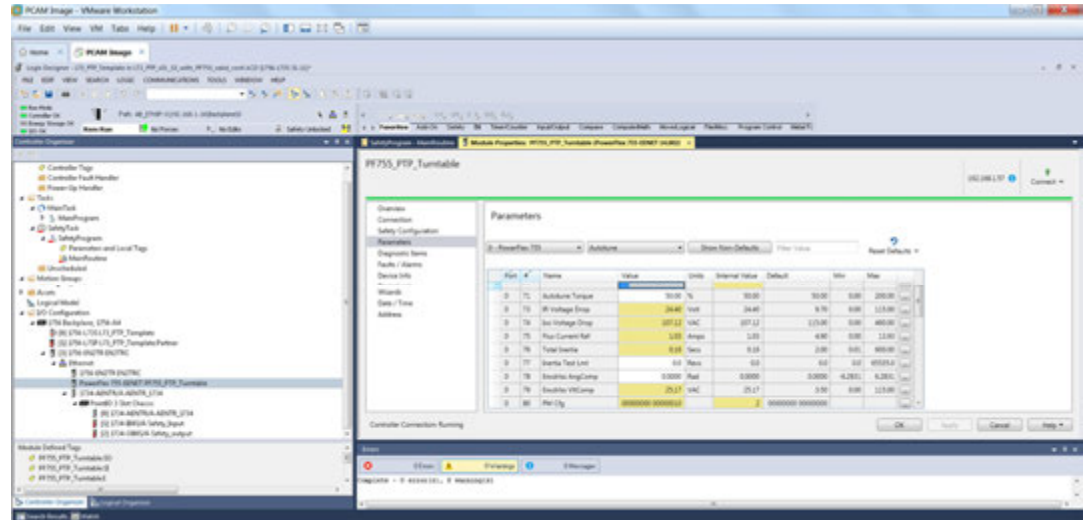

After the Inertia Tune has completed, **00:76 [Total Inertia]** is updated. This number represents how long it takes to accelerate the Motor being used from 0 RPM to Motor Nameplate RPM speed at 100% motor torque. This test can be redone after coupling to the machine or calculated and entered into the parameter from a formal sizing process. Typical values of this parameter range from 0.1 ...2 for most applications.

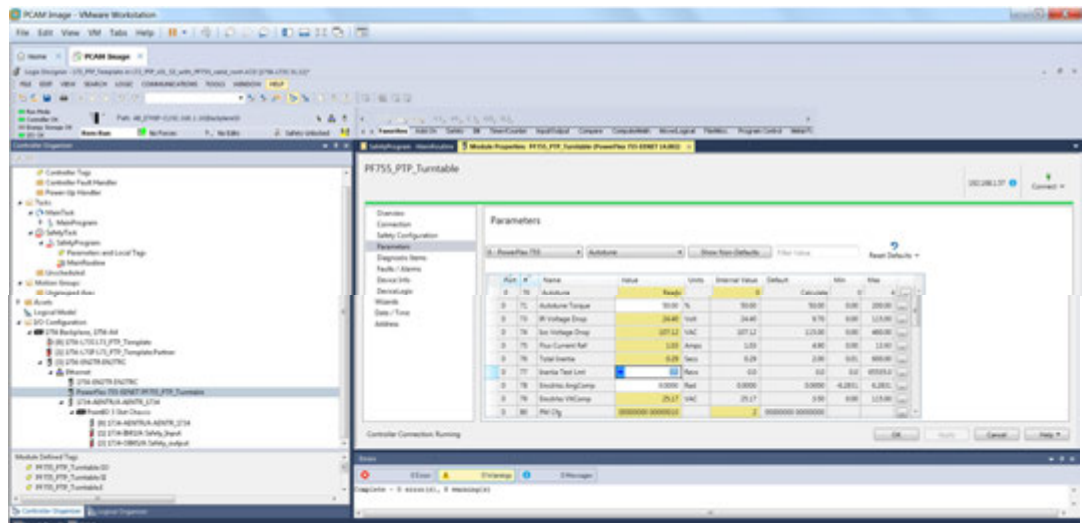

Direction Verification

The direction verification procedure can be performed with or without the load attached. Consider your application requirements when deciding to have the load attached or removed from the motor. The procedure confirms motor rotation and feedback polarity.

After the procedure is complete, a change can be made, if necessary.



ATTENTION: If the drive was never operated before (new installation), verify that safeguards are in place to remove power safely from the drive during an unstable situation where the drive can produce undesired motion.



ATTENTION: This procedure causes movement of the motor shaft and of any connected equipment. To guard against personal injury or damage to equipment, verify that all guards are properly installed to help protect against contact with rotating parts.

1. On the Parameters page, change the selection to **0-PowerFlex | Feedback | Show Non-Defaults**, so that the encoder direction can be observed.
2. Use a Logix controller or HIM to jog the drive and observe the direction of the motor in **00:131 [Active Vel Fdbk]**.
3. Compare the direction to the encoder direction in **00:130 [Alt Vel Feedback]**.
4. If they match as shown, you do not have to change the electrical direction of the encoder.

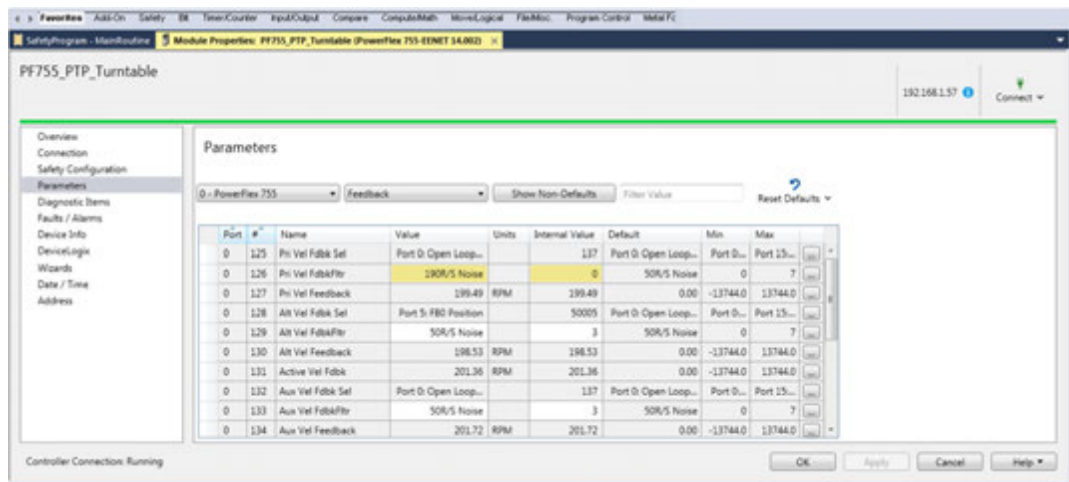

5. If they don't match as shown, you have to change the electrical direction of the encoder to forward.

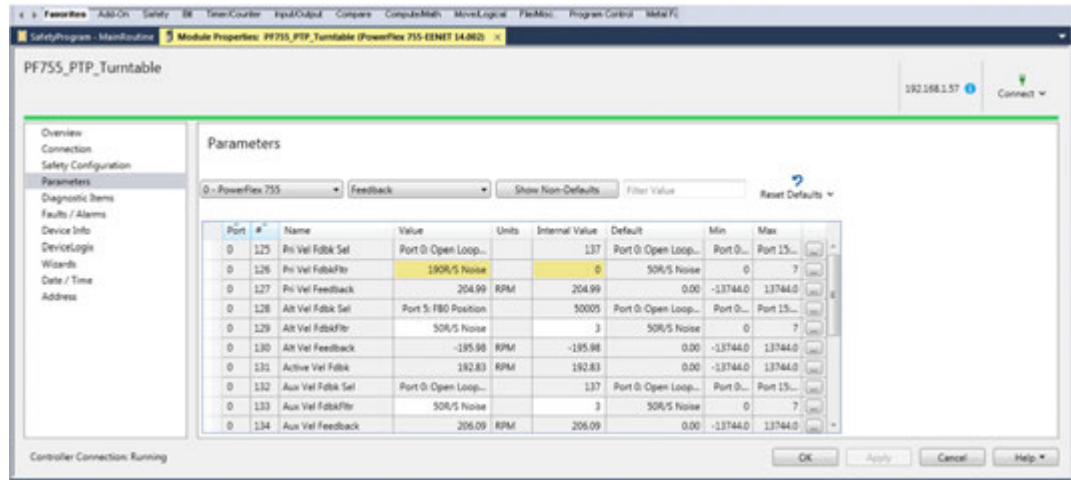

- a. To change the encoder rotation to the forward direction, view the port that contains the encoder feedback.

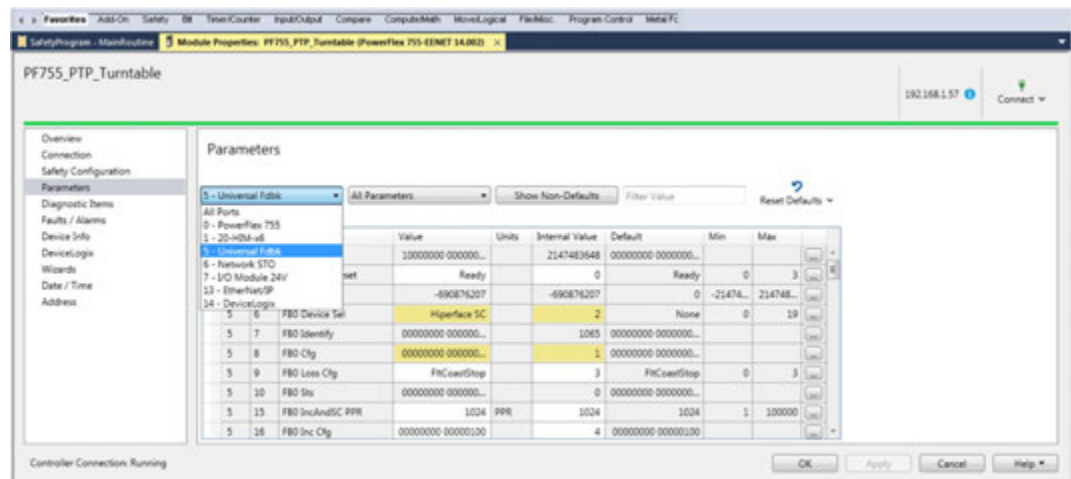

- b. In the encoder port, select Feedback Configuration in the pull-down menu. In our example, a UFB in **05:08 [FBO Cfg]**.

- c. Edit the bits to invert the direction from the present status to rotate in a forward direction.

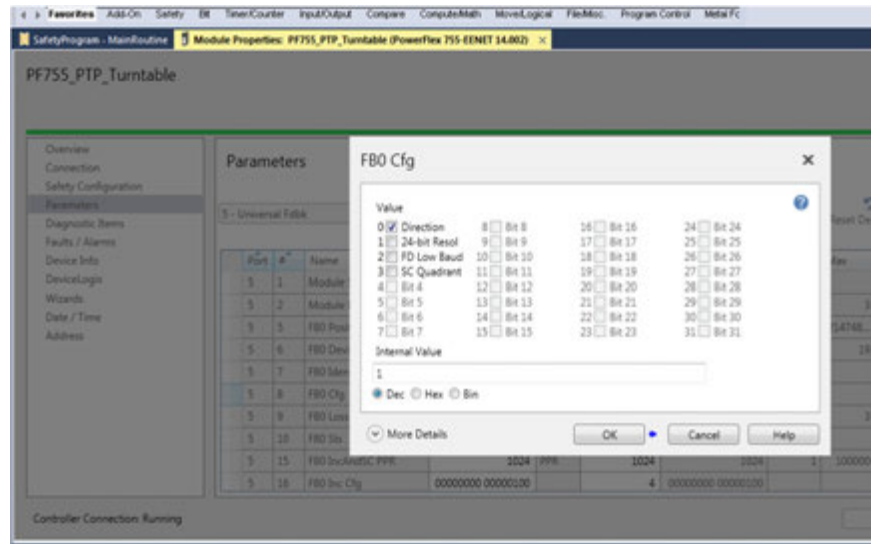

- d. Return the drop-downs on the Parameters page to **0-PowerFlex | Feedback | Show Non-Defaults**.
- e. Jog the unit again and verify that **00:130 [Alt Vel Feedback]** and **00:131 [Active Vel Fdbk]** show the same direction and approximately the same velocity.

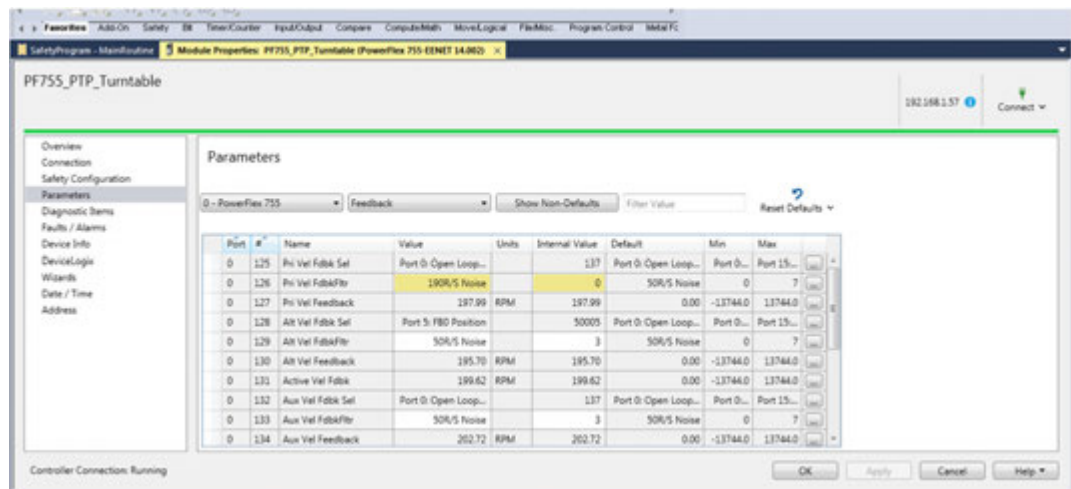

- After motor and encoder directions are verified, change **00:125 [Pri Vel Fdbk Sel]** back to the original configuration so it is used by **00:131 [Active Vel Fdbk]** velocity loop for the drive as desired.

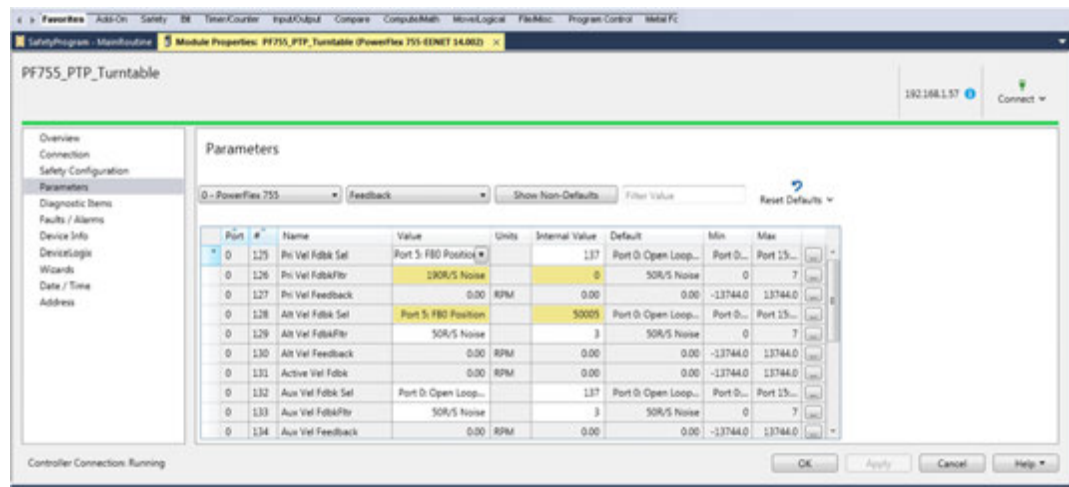

TIP Revert to the information that was recorded in [step 2](#) on [page 98](#) of the Autotune Test.

- Next run or jog the drive from the Logix controller and verify the performance.

As a guide, the Speed should be within +/- 1 RPM or 2 RPM of the commanded speed.

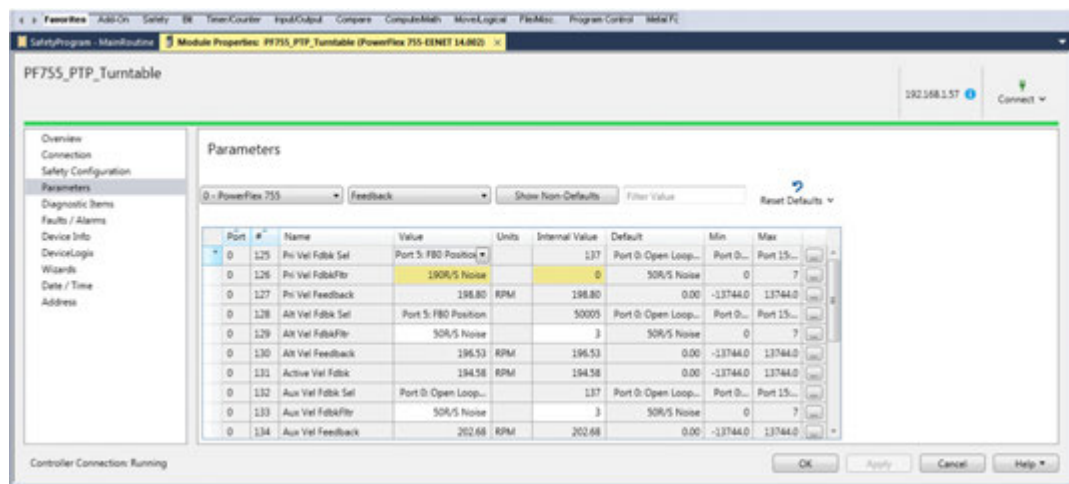

- Use the Trend function to capture data and observe behavior. For more information on using trend, see [Configure an RS Trend on page 88](#).

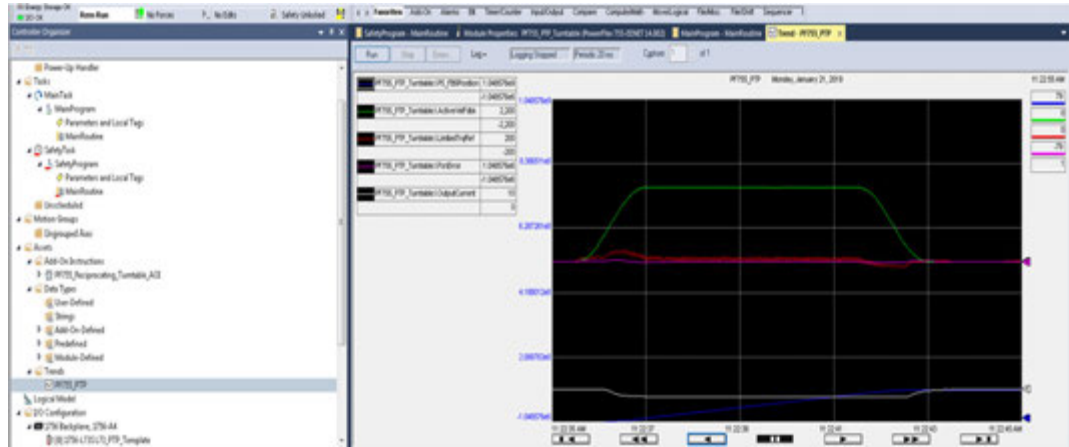

Application Tuning

If the performance (Speed, Position regulation) is not adequate, refer to PowerFlex 700S and PowerFlex 755 Drives Tuning, publication [DRIVES-AT004](#) for guidance on setting the various parameters associated with tuning.

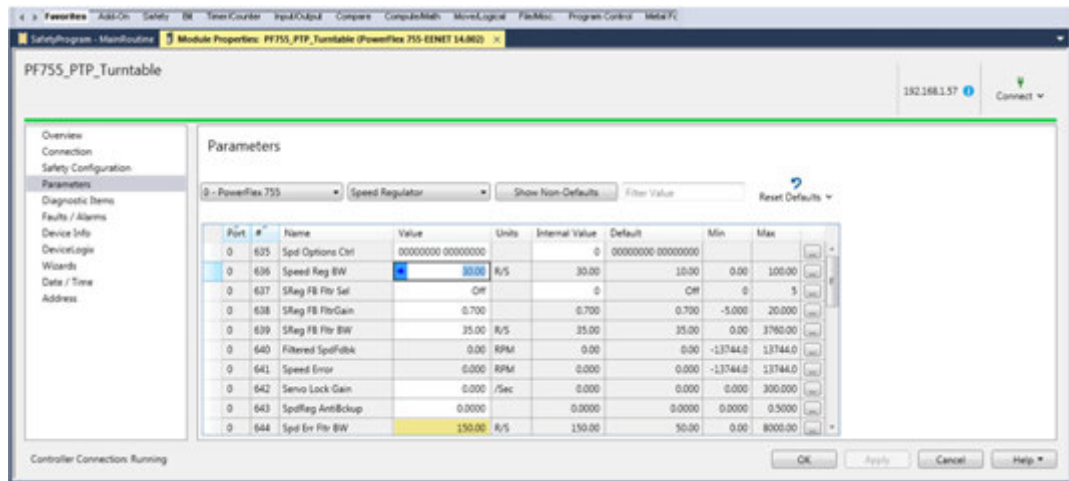

IMPORTANT For a point-to-point (PTP) positioning application, **00:76 [Total Inertia]**, **00:636 [Speed Reg BW]**, and **00:839 [Psn Reg Kp]** are adjusted to obtain desired performance.

00:839 [Psn Reg Kp] is typically set to be 1/3 or 1/5 of the **00:636[Speed Reg BW]** value.

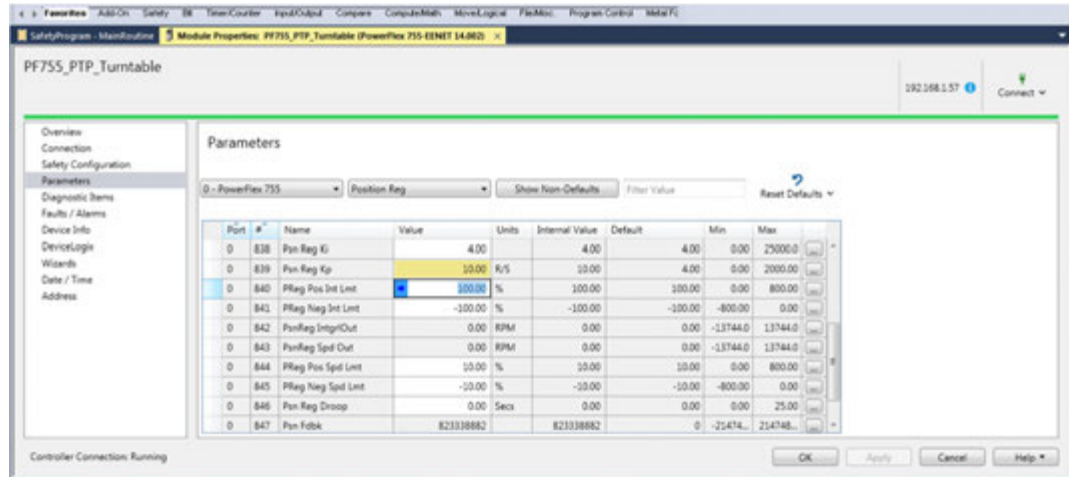

Connect the Motor to the Machine

1. After the performance is configured, connect the motor to the machine, and repeat the Jog +/- to observe performance.
2. Adjust parameters to obtain machine performance as required.
3. Use the RS Trend function to observe the performance. For more information on using trend, see [Configure an RS Trend on page 88](#).

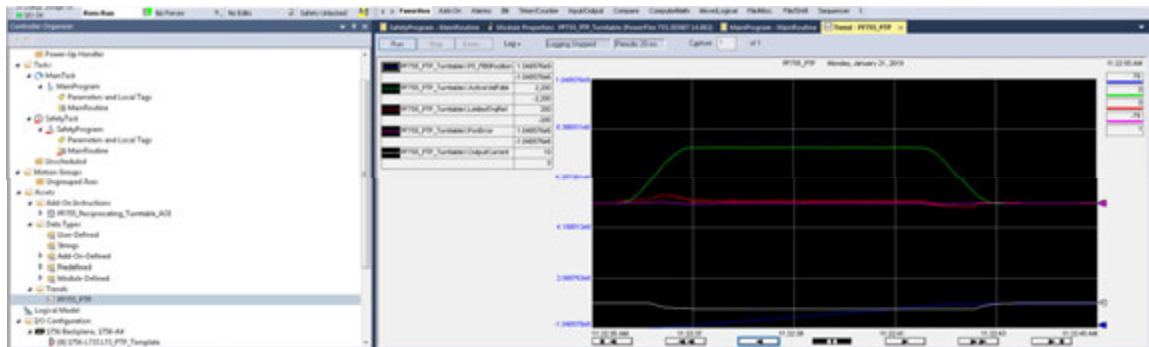

4. When performance is acceptable, click OK to close the PowerFlex 755 drive properties.

IMPORTANT You must close the project to sync the drive parameters to the Logix controller.

Synchronize the Drive

1. Right-click the drive in the Controller Organizer and select Properties to open the Module Properties dialog box.

It will connect and compare the Logix project drive parameters to the PowerFlex 755 drive parameters. Because we adjusted numerous parameters in the previous steps to tune the drive and the motor, the adjusted parameters in the drive appear.

2. Choose Use Physical and click OK to import the changes into the Logix project.

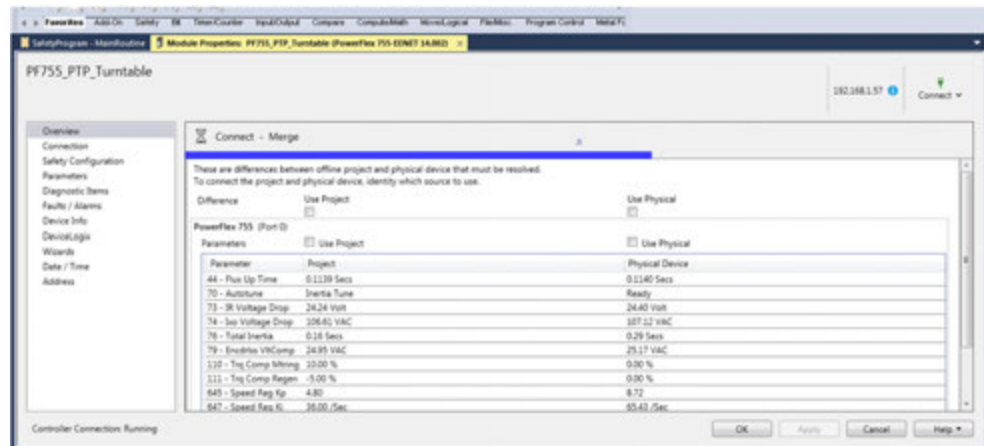

3. After the parameters have uploaded into the Logix Designer application project and the system is synchronized, save the Logix Designer application program so the online and offline program match.

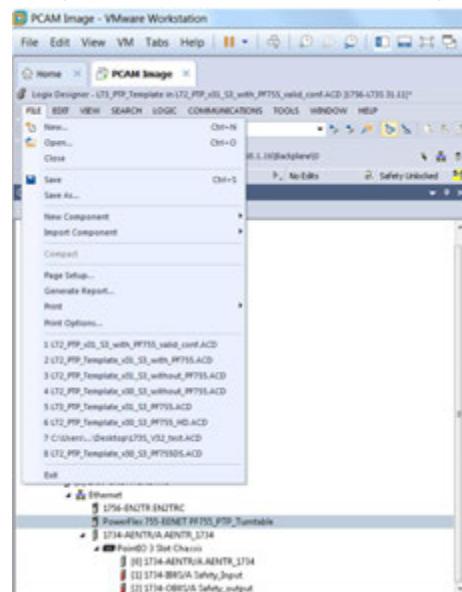

4. Click Yes to confirm that you want to save the project and upload the new tag values.

Application Notes

This section provides an example of how to calibrate the a load side SSI feedback, if utilized.

Example: For the universal feedback device, the **05:25 [FB0 Lin CPR]** calculation uses the data in the image.

Motor Encoder feedback = 4096 counts per motor revolution (1024 PPR)
 X = motor encoder counts (P4 of incremental encoder feedback device)
 Y = coded rail counts (P5 of UFB)

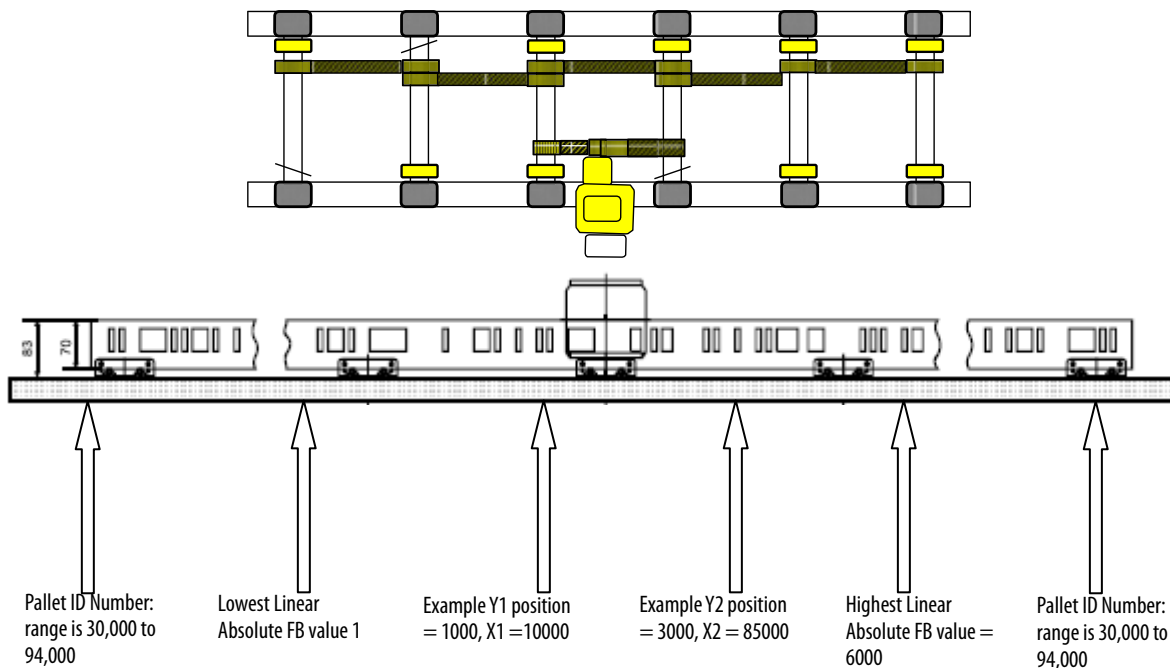

Example calculation for **05:25 [FB0 Lin CPR]** of the universal feedback device. CPR is the linear feedback counts per 1 motor revolution. By using the incremental encoder feedback counts (**04:04 [Enc 0 FB]**) of the single encoder feedback device or **04:04 [Enc 0 FB]** or **04:14 [Enc 1 FB]** for the dual encoder feedback device and the linear position feedback device **05:05 [FB0 Position]**.

$$Y1 = 1000, Y2 = 3000, X1 = 10,000, X2 = 85,000$$

$$Y2 - Y1 = 2000 \text{ delta linear feedback counts}$$

$$X2 - X1 = 75,000 \text{ delta motor encoder counts}$$

$75,000 / 4096 = 18.3105$ motor revolutions (as determined by motor encoder revolutions) which calculates the Linear counts per motor revolution solve:

$2000 \text{ linear delta feedback counts} / 18.3105 = 109.226 \text{ Linear counts/motor rev.}$ Because this value must be entered as an integer, Round off to 109, and enter it into universal feedback device, **05:25 [FB0 Lin CPR]**. This parameter then correlates the position loops linear speed reference with the rotary speed feedback of the motor.

Drive Start Up – Integrated Motion mode (CIP Motion)

Use the Logix Designer application and verify that the GuardLogix or CompactGuardLogix controller firmware is at the minimum required level to allow the On-Machine Drive to be controlled properly. In these steps, we use a GuardLogix 1756-L84S with V32.00 firmware and a PowerFlex 755 V14.00 firmware drive. The Add-on Profile (AOP) for the drive is V19.01.83.0. The drive has a 20-750-UFB-1 feedback device in slot 5, a 20-750-S3 Network STO option module in slot 6, and a 20-750-2263C-1R2T in slot 7.

See [Prepare for Initial Drive Start Up on page 50](#) for startup information. Additionally, the resources that follow provide additional information that you should reference when completing start up using integrated motion.

Resource	Description
Integrated Motion on the EtherNet/IP Network: Configuration and Start Up User Manual, publication MOTION-UM003	Use this manual to configure an integrated motion on the EtherNet/IP network application and to start up your motion solution with a Logix controller-based system.
Motion System Tuning Application Techniques, publication MOTION-AT005	The purpose of this publication is to assist you in tuning a Kinetix drive system. This document is intended for motion control users with novice to advanced skill levels that are familiar with the following: <ul style="list-style-type: none"> • Kinetix servo drives • Servos or EtherNet/IP communication • Use of the Logix Designer application to create a motion axis • Understanding how control loops work in motion control applications Each component of the control structure is described in detail and out-of-box tuning, autotuning, and manual tuning techniques are presented.
Integrated Motion on the EtherNet/IP Network Reference Manual, publication MOTION-RM003	Use this manual to review descriptions of the AXIS_CIP_DRIVE attributes and the Logix Designer application Control Modes and Methods. It is intended for use as a reference when programming motion applications
Product Comparability and Download Center, see https://compatibility.rockwellautomation.com	Get help determining how products interact, check features and capabilities, and find associated firmware.

TIP The procedure is written for the Network-Integrated Safe Torque Off (S3) option module. The same procedure, with slight modifications, works for both Network-Integrated Safety Function (SSM) and Network-Integrated Safety Function with Brake Control (S4) option modules.

TIP Variations to the procedure for the SSM or S4 option modules, will appear as tips throughout the procedure.

Add Drive to the I/O Project

In the following steps, we give detailed instructions to start up a drive using integrated motion.

1. Right-click the Ethernet network in the Controller Organizer and select New Module to add the PowerFlex 755 drive to the EtherNet/IP network.
2. In the Select Module Type dialog box, type PowerFlex 755.

3. Scroll through the list and select your safety option module:

Choose PowerFlex 755 EENET-CM-S3 for the Safe Torque Off (S3) option A.

Choose PowerFlex 755-EENET-CM-S4 for the Network Integrated Safety Function (S4) option B or option C.

Choose PowerFlex 755-EENET-CM if no safety option module is used. Refer to the [Catalog Number Explanation on page 16](#) for more information.

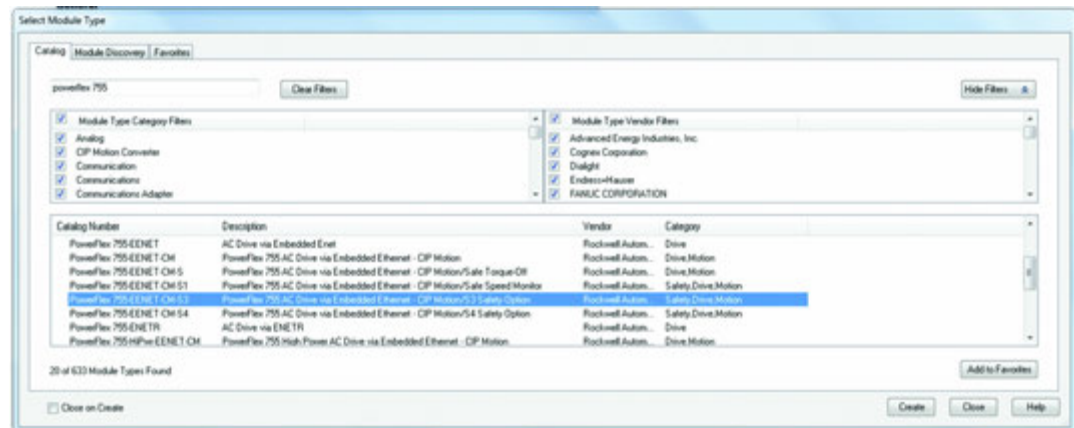

4. On the General page of the Module Properties dialog box, type a Name, Description (optional), and the IP address of the drive.

In this example, we use PowerFlex 755_CIP_Turntable and an IP address of 192.168.1.54.

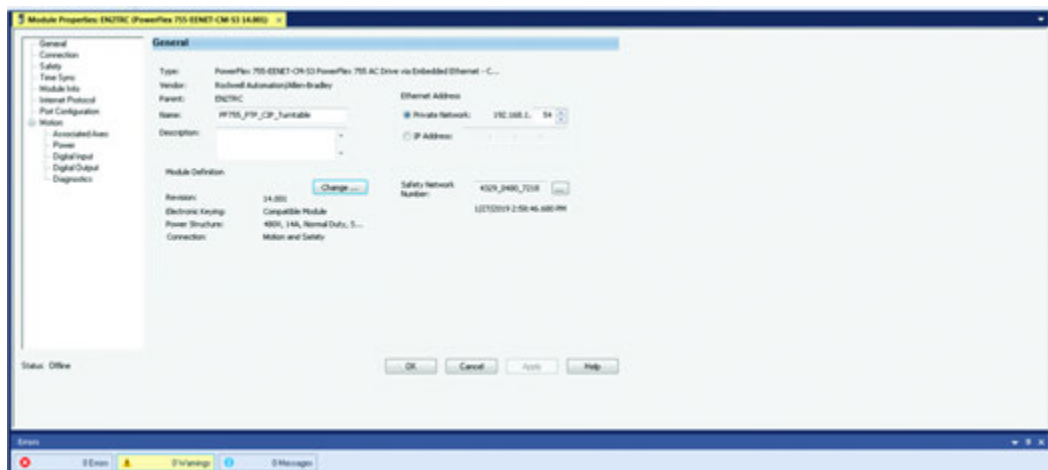

5. Click Change.

Select Peripheral Devices and Slot Assignments for Option Modules

Peripheral and feedback devices on the PowerFlex 755 drives are called option modules. You must assign the port/channel/slot for each device you are using.

Check electrical drawings and the catalog number for specific details regarding which option modules are installed in slots 4, 5, and 7. See [Prepare for Initial Drive Start Up on page 50](#) and [Catalog Number Explanation on page 16](#) for more information.

1. From the Module Definition dialog box, right-click on the Drive shown and Select New Peripheral Device.

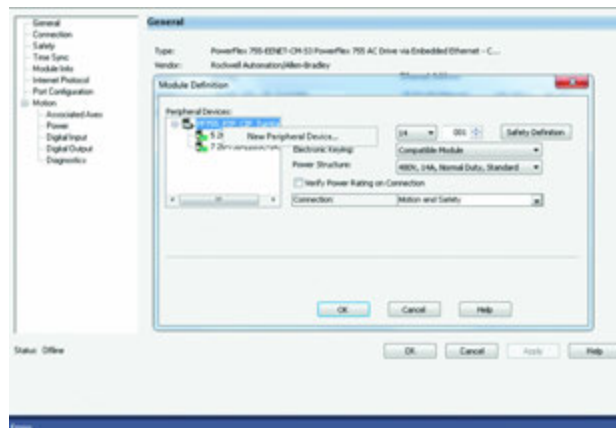

2. On the Peripheral Device Definition dialog box, add the option modules that are provided in your drive.

For each option module, choose the appropriate port and the corresponding peripheral device.

3. After each option module is added, click OK.

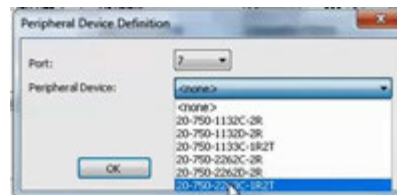

TIP For option modules that use SSM or S4 option modules, it is recommended to assign the universal feedback module (UFB) in slot 5.

4. Repeat step [2-3](#) for each option module.

5. **For S4 only:** Select the drop-down menu for the safety instance, and choose Single feedback monitoring for a single encoder or dual feedback monitoring for multiple encoders.

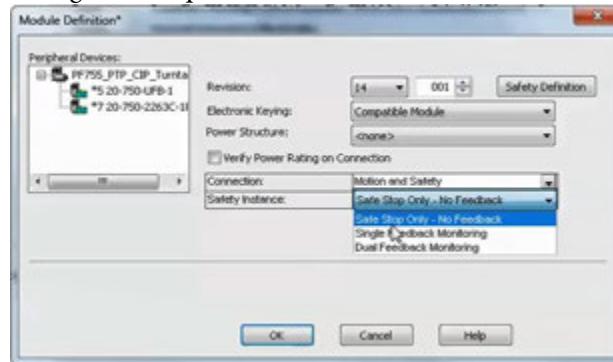

6. From the Power Structure pull-down list, select the appropriate power structure. You can locate the power-structure reference numbers in these ways:
 - On the actual product, usually on the right side of the drive
 - In the device documentation
 - On a purchase order

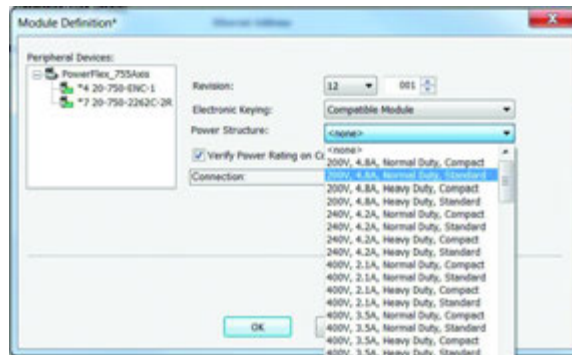

In our example, we selected 480V, 14 A, Normal Duty Standard.

7. Set the Connection type to Motion and Safety.

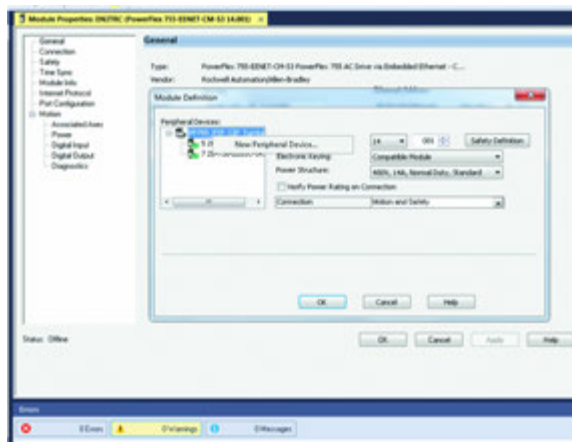

- After all data has been entered properly, click OK.

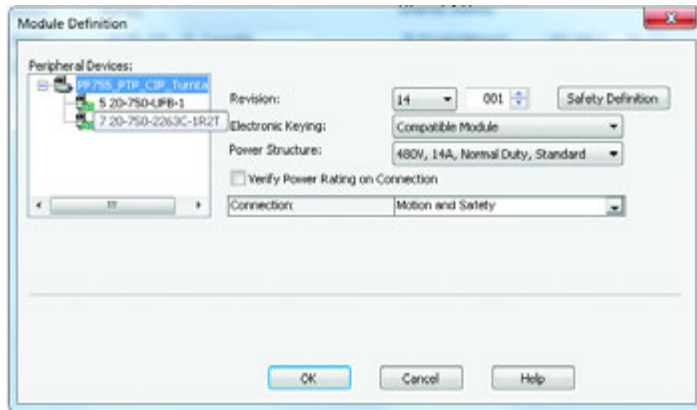

IMPORTANT When you change the major revision on the PowerFlex 755 drive, change the power structure, or change the option module, the axis is no longer associated with the modules.

- The following message appears. Click Yes to apply the changes.
When you change parameters, other related parameters change as well.

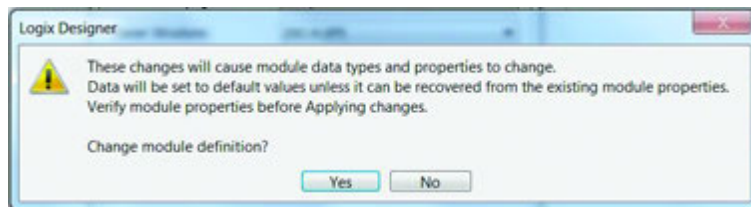

This message always appears after you have changed a configuration. This message is a reminder that when you change the power structure, the identity of the drive changes. If your drive is associated to an axis and you change the power structure, the axis is disassociated.

Even though a feedback device has been selected, the drive is not configured. You must associate the axis first, and then you have the option to configure a feedback module.

- On the General page, click OK to apply the changes.

Create an Associated Axis

There are two approaches that you can take to create and configure an axis. You can create an axis first and then add the axis to your motion group, or you can create your motion group and then add an axis. The procedure that is outlined in this section takes the approach to create your axis first, configure the axis, and then add it to your motion group.

Create an Axis for a PowerFlex 755 Drive

You need to create a New Axis. This associates the PowerFlex 755 to a Motion Axis.

1. In the Module Properties dialog box, under the Motion tree, choose Associated Axis.
2. Click Ok in the dialogue box to open Select Module Type.
3. Close the Select Module Type dialogue box.
4. Double-click on the module to re-open the Properties Dialogue box.
5. In the Module Properties dialog box, under the Motion tree, choose Associated Axis.
6. Click New Axis.

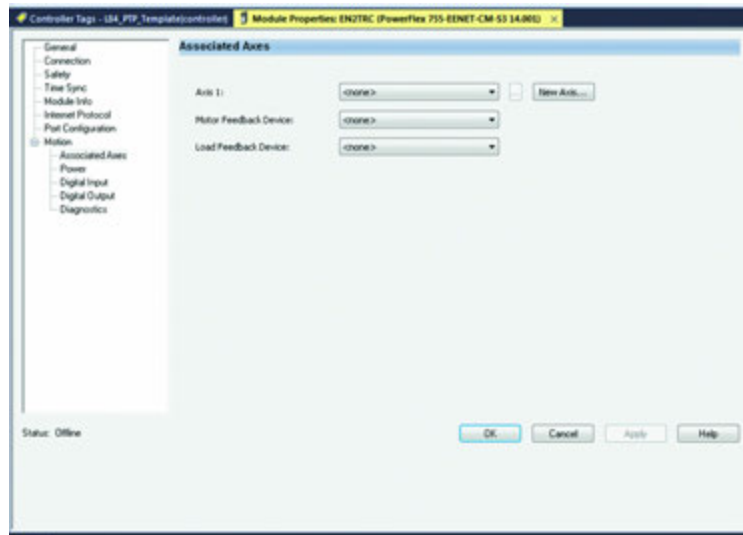

7. Type a name for the New Motion Axis.
8. Type a description if desired.

- After entering the information from step 6-8, change the Tag Type, Data Type, Scope, class, and External Access, if needed.

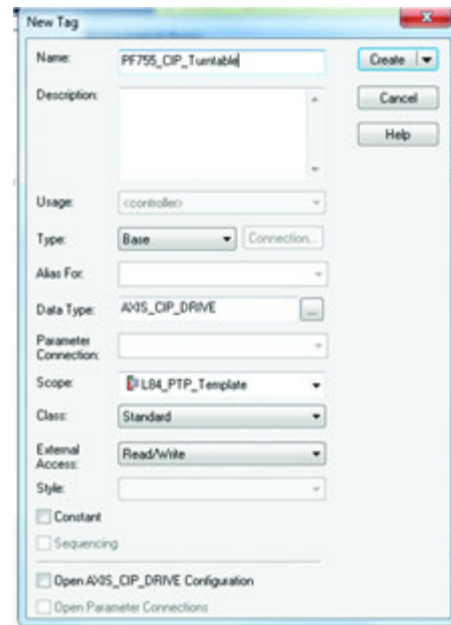

- Click Create.

For more information about External Data Access Control and Constants, see the Logix 5000 Controllers I/O and Tag Data Programming Manual, publication [1756-PM004](#).

Establish Option Module Port Assignments

The ports and channels that you can select are related to which hardware you have installed. You must manually establish the motor feedback option module (Port/ Channel) assignment for the PowerFlex 755 drive. Follow these instructions to associate an axis to the drive by using the Module Properties dialog box for the drive.

See the electrical drawings and the catalog number for help with identifying the proper encoder configuration sources for the Motor Velocity Feedback and Load side Position feedback (if used). In our example, we have a Hyperface encoder that is wired into a 20-750-UFB option module via channel A.

- Right-click on the PowerFlex 755 drive and select Properties.

- In the Module Properties dialog box, choose the Associated Axes page.

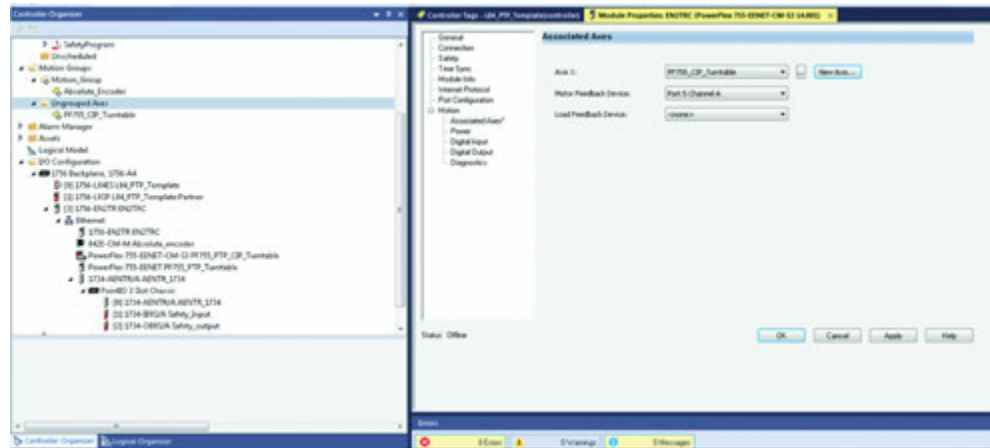

- From the Feedback Device pull-down menus, select the port and channel combination that is applicable to your hardware configuration. This is what you installed when you added a option module to your drive. In this case, Port 5 Channel A is associated with the motor feedback option module.
- Click Apply.

TIP If a failure message occurs, open and reconfigure the Ethernet card Time Sync. Starting at the Project Tree, open/select in the following order: I/O Configuration > Ethernet Card > General Tab > Module Definition > Change ... > Time Sync and Motion > Yes. Return to Module Properties screen shown in step 2.

- Click OK to close the Associated Axes dialog box.

Configure Power Options

Use the settings on the power page to set bus regulator action, select shunt resistor type, and configure limits. Configure the drive dynamic brake (DB) values (if used and wired to DBR receptacle).

- On the Module Properties dialog box, choose the Power page.
- Type the manufactures information for dynamic brake resistor values into the corresponding fields.
- Set the:
 - Bus Regulator Action to Shunt Regulator
 - Regenerative Power Limit to -200%
 - Shunt Regulator Resistor Type to External and
 - External Shunt to Custom.

See the [Prepare for Initial Drive Start Up on page 50](#) for more information.

- After the information is entered, click Apply to save changes.

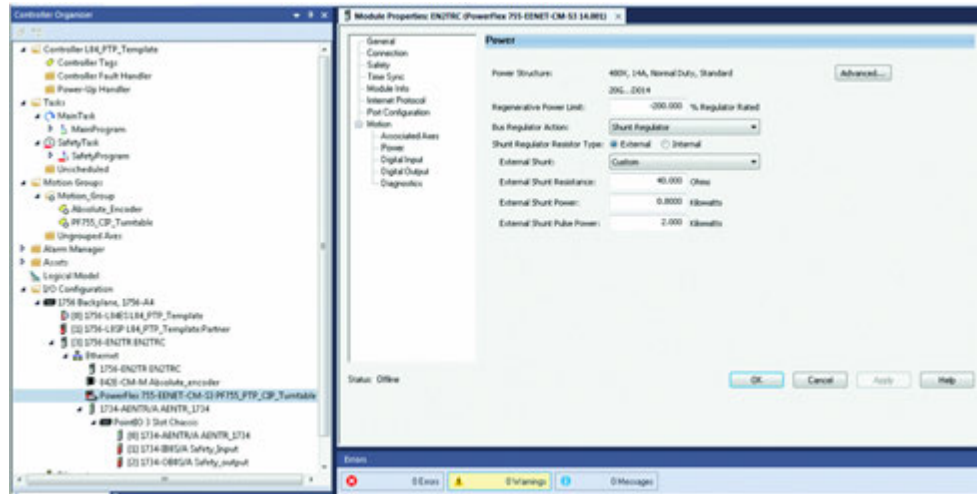

Configure Digital Inputs

Use the Digital Input page to enter digital input values for the drive option module. The appearance of this page for the PowerFlex 755 drives can vary dependent upon the option module configuration. Use the Digital Input page to assign specific actions to the inputs on the I/O option module that is located in slot 7 of the drive. The drive is configured per the following table.

TIP Under axis properties, you may also elect to have the Logix controller read the digital inputs as PLC I/O. See the electrical drawings for details regarding the I/O wiring. It is recommended to not change digital inputs.

Digital Input	Description
1	DBRT – dynamic brake resistor thermostat
2	Electromechanical brake contactor auxiliary contact
3	Main circuit breaker and brake circuit breaker auxiliary contact input
4	P0 receptacle – Digital Input 2 and Digital Input 3 (20-750-2263C-1R2T I/O option module)
5	
6	P1 receptacle – Digital Input 4 and Digital Input 5 (20-750-2263C-1R2T I/O option module)
7	
8	Not wired

- From the Module Properties dialog box, choose Digital Input.
- Change the value of the inputs.
- Click Apply to save changes.

4. Click OK to exit Module Properties.

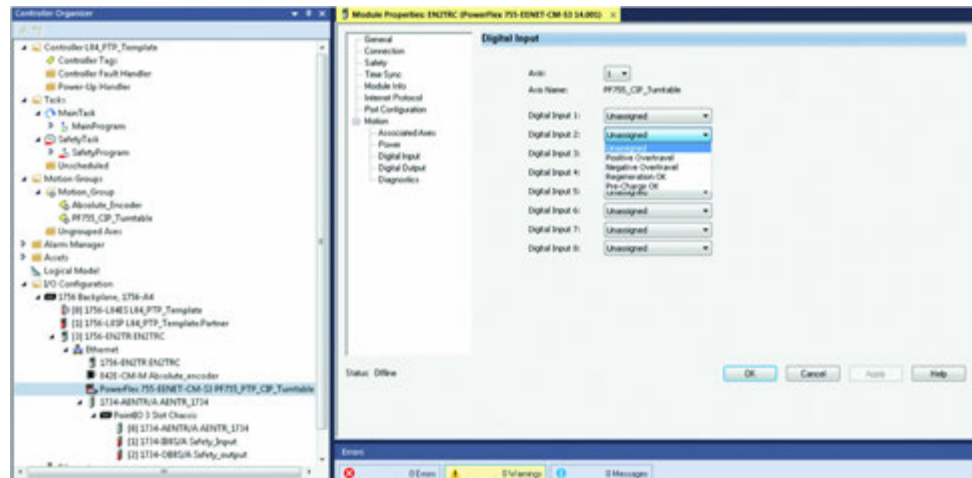
*Configure Digital Outputs*

Use the Digital Outputs page to enter digital output values for the drive option module. The Digital Outputs page applies only to a PowerFlex 755 drive that is configured with a Digital I/O option module as a peripheral device. The appearance of the Digital Outputs page varies dependent upon the option module configuration.

Use the Digital Output page to assign specific actions to the outputs on the I/O option module that is located in slot 7 of the drive.

See the electric drawings to observe that Digital Output 1 is wired in parallel to Digital Output 2. From the 20-750-2263C-1R2T option module, relay 0 and transistor 0 are wired in parallel.

Digital Output	Description
1	20-750-2263C-1R2T Relay 0
2	20-750-2263C-1R2T Transistor Relay Output 0
3	20-750-2263C-1R2T Transistor Relay Output 1 (not used)

The Logix controller can have logic written that may energize Output 2 when the axis isn't running. This logic releases the motor brake, but only on horizontal applications.



ATTENTION: Failure to observe this warning can result in machine damage or personnel injury. Do not use Output 2 shown in [step 4](#) on page [122](#), when the application is vertical (Gravity can influence movement).

1. On the Module Properties dialog box, choose Digital Output.

2. Change the value of the inputs.

IMPORTANT It is critical that you assign **07:01 [Dig In Sts]** Digital Output 1 to Mechanical Brake Engage so that the Logix controller properly sequences the electromechanical motor-mounted brake when running or jogging the motor. The drive is configured per the following table.

3. Click Apply to save changes.
4. Click OK to exit Module Properties.

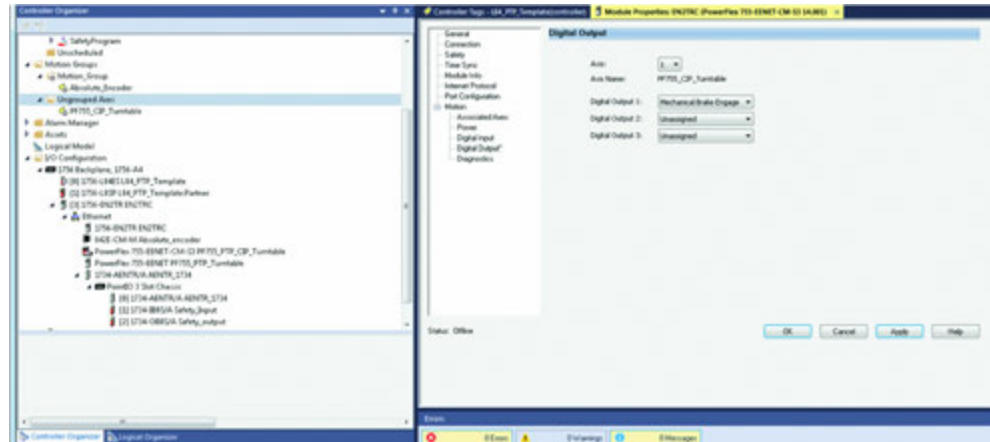

Configure I/O Actions (SSM and S4 only)

Refer to the PowerFlex 755/755T Integrated Safety Functions Option Module (S4), publication [750-UM005](#) for additional information about which I/O configurations are acceptable for your environment.

1. From the Module Properties dialog box, choose Actions.

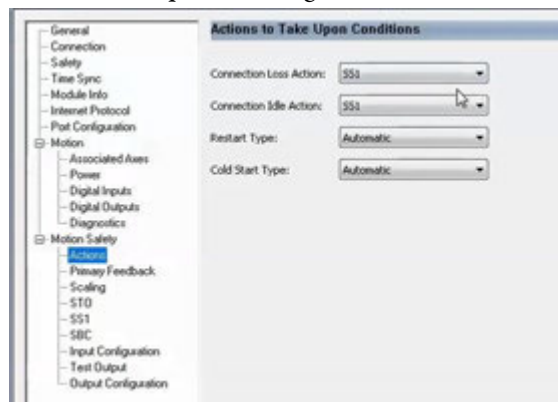

2. Change Connection Loss and Connection Idle to the option that is most applicable to your environment.
3. Click Apply to save changes.

- From the Motion Safety tree, choose Primary Feedback.

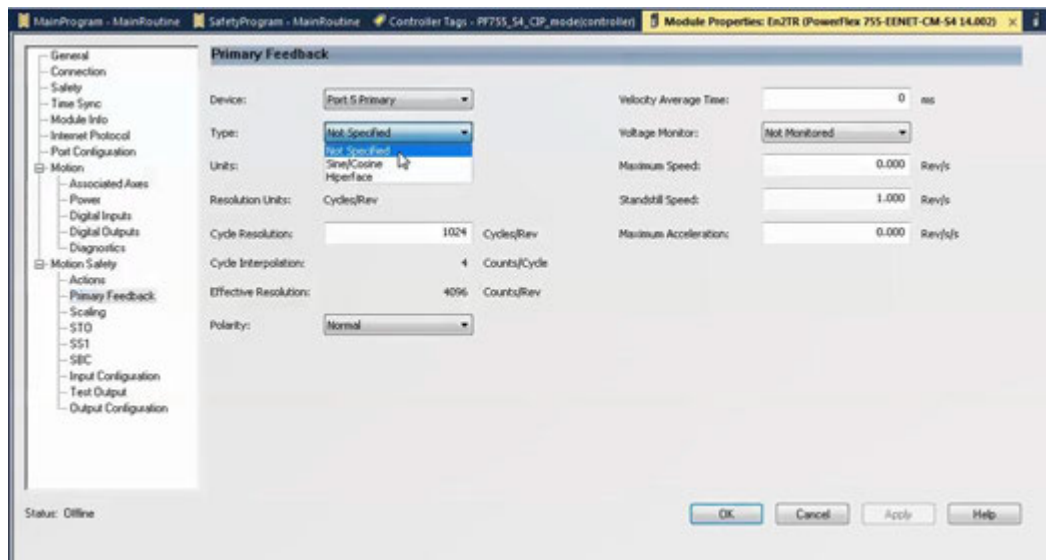

- Change Type to Hiperface.

TIP You could choose to set the Max. Motor Speed at this time, refer to the PowerFlex 755/755T Integrated Safety Functions Option Module (S4), publication [750-UM005](#), for parameter and setup information.

- Click Apply to save changes.
- From the Motion Safety tree, choose Scaling.

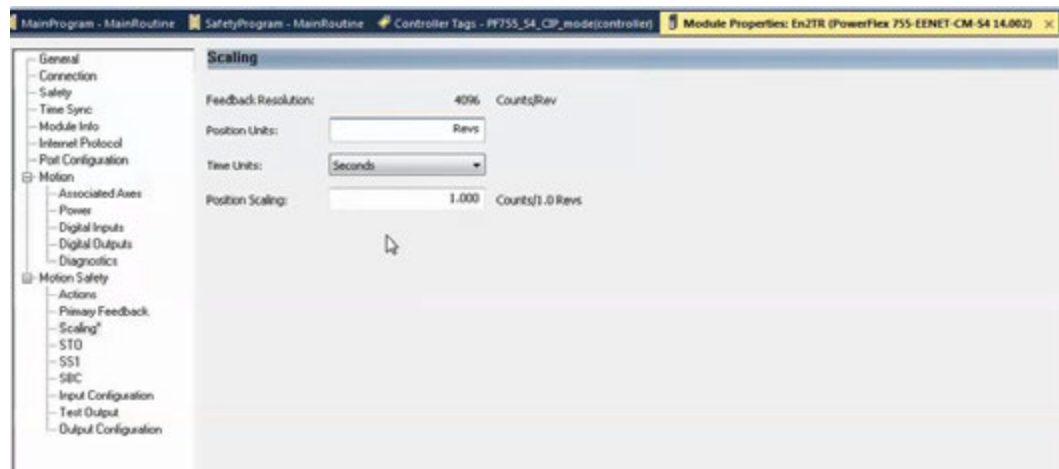

- Change Scaling to Revs.
- Click Apply to save changes.

Create a Motion Group

All axes must be configured properly and added to the Motion Group in your project. If the axes remain ungrouped they are unavailable for use. For

information on creating a motion group, refer to the associated controller manual. [Table 7](#) shows the controller compatibility.

Table 7 - Safety Controller System Requirements

Safety Option Module		20-750-53 Integrated Safe Torque Off Module		20-750-54 Integrated Safety Functions Module	
Mode of Operation		I/O mode	Integrated Motion mode	I/O mode	Integrated Motion mode
Minimum Drive Firmware Required		Version 13	Version 14	Version 14	Version 14
Minimum Controller Firmware Required	GuardLogix® 5570, Compact GuardLogix 5370, Armor GuardLogix 5570 Controllers	Version 30	Version 31	Not supported	Not supported
	GuardLogix 5580, Compact GuardLogix 5380 Controllers	Version 31		Version 31	

1. In the Controller Organizer, right-click Motion Groups and select New Motion Group.

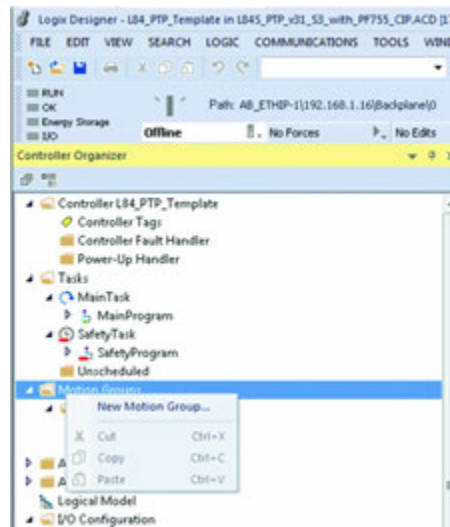

2. Type a name.

In our example we named the Motion group - Motion_Group.



3. Type a description, if desired.

The fields in the next steps are automatically entered for the `_name_` date type.

4. Change the Tag Type, Data Type, Scope, and External Access, if needed.

For information about External Data Access Control and Constants, see the Logix5000 Controllers I/O and Tag Data Programming Guide, publication [1756-PM004](#).

5. Click Create.

Your new motion group appears in the Controller Organizer under the Motion Groups folder.

Add Axis to Motion Group and Assign

To move the axis you created into the motion group that you created, follow these steps.

1. In the Controller Organizer, select the axis.
2. Drag and drop the axis into the motion group folder.
3. Expand the drop-down next to the motion group folder to verify the axis moved.

4. Right-click the new motion group and select Properties.

The Motion Group Properties dialog box appears.

5. Choose the Axis Assignment tab and move your axes from Unassigned to Assigned.

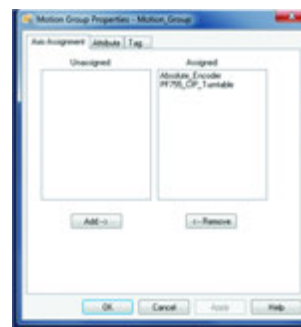

6. Click Apply.
7. Click OK to close the Motion Group Properties dialog box.

Set the Base Update Period

The Base Update Period is basically the data rate for Ethernet communication between the controller and the motion option module, performed through a Unicast connection. It also sets the motor feedback rate that is returned from the drive in the drive-to-controller connection.

There are two alternate update periods that you can configure when using Axis Scheduling.

The Base Update Period determines how often the motion planner runs. When the motion planner runs, it interrupts most other tasks regardless of their priority. The motion planner is the part of the controller that takes care of position and velocity information for the axes.

Follow these steps to set the Base Update Period

1. In the Motion Group Properties dialog box, choose the Attribute tab.
2. Set the Base Update period to an interval between 4.0...32.0 ms.

For the PowerFlex 755 drive, the minimum Base Update Rate is 4.0 ms.

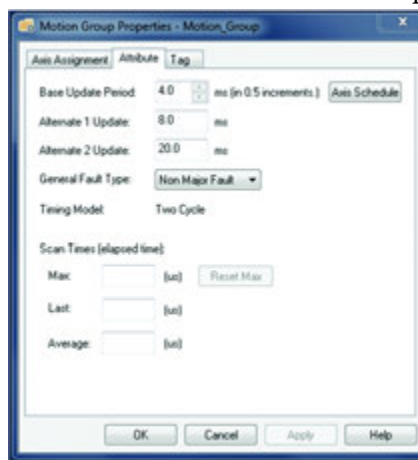

3. Click on Axis Schedule to open the scheduler.

For detailed information on the Axis Scheduling function, refer to Integrated Motion on the EtherNet/IP Network: Configuration and Start Up, publication [MOTION-UM003](#).

Logix allows the axis to use one of three course update rates. The Base Update period for Alternate 1 and 2 must be a multiple of the Base Update period. We recommend that the drive be set to a Base Update Period of 4 ms when the drive is used for Positioning. (Minimum allowed is 3 ms). For all other modes of control (speed, torque, Volts/Hertz, and so on) we recommend an Update Period of 20 ms.

- From the pull-down menus, select your desired time intervals.

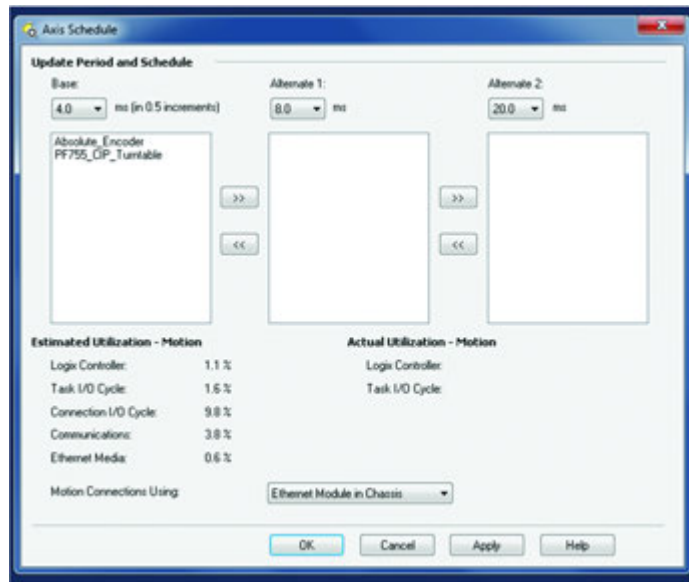

- Click Apply to save changes.
- Click OK to close the dialog box.

Configure the Axis Properties, the Associated Axis, and Control Mode

See the Integrated Motion Reference Manual, publication [MOTION-RM003](#), for complete information on Axis Attributes and how to apply Control Modes.

At this point, the configuration is still offline and has not been downloaded into the controller.

IMPORTANT Be sure to associate the drive to the axis before configuring the axis, because the drive determines which peripheral devices are supported for the axis. The Motion Group must be defined and scheduled to properly complete this procedure. All AXIS_CIP_DRIVE Axis Properties dialog boxes are dynamic.

- Double-click on the axis (PF755_CIP_Turntable) to open the Axis Properties dialog box.

- Choose the General page.

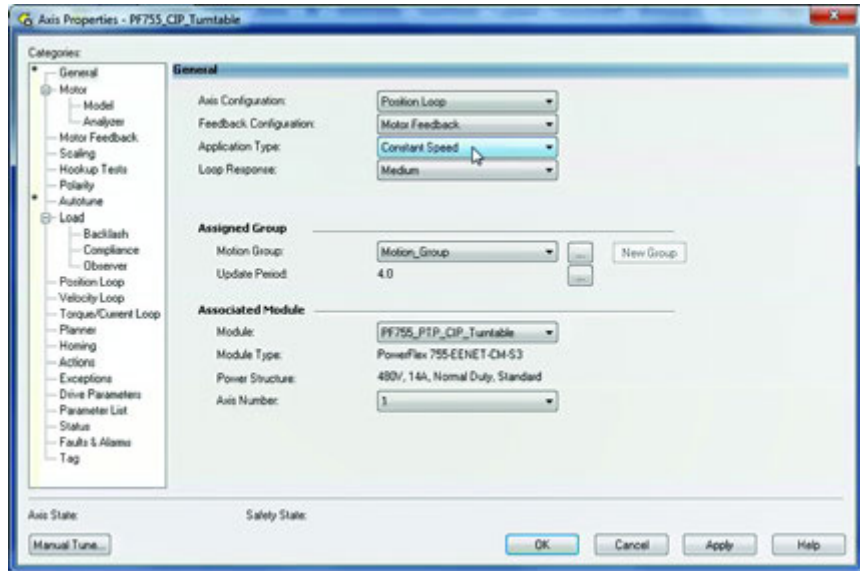

For the PowerFlex 755 On-Machine Drive, Rockwell Automation recommends that you select Constant Speed for either an induction or a servo motor.

Choose an Axis Configuration type. The available configurations are: Position Loop (P), Velocity Loop (V), Torque Loop (T), and Frequency Control (F).

See [Application Notes on page 111](#) for more information related to position loop setup.

- Choose a Feedback Configuration type, the table compares feedback type and loop type.

Feedback Type	Axis Type	Supported
Motor Feedback	Position Loop (P), Velocity Loop (V), Torque Loop (T)	Yes
Motor Feedback	Position Loop (P), Velocity Loop (V)	No
Load Feedback	Position Loop (P), Velocity Loop (V), Torque Loop (T)	No
Dual Feedback	Position Loop (P)	Yes
Dual Integrator	Position Loop (P)	Yes
Master Feedback	Feedback Only (N)	No
No Feedback	Frequency Control (F)	Yes
No Feedback	Velocity Loop (V)	Yes

- Choose and Application Type, if applicable.

The Application Type determines the type of motion control application. This attribute is used to set the Gain Tuning Configuration Bits.

Application Type	Kpi	Kvi	ihold	Kvff	Kaff	torqLPF
Custom ⁽¹⁾	-	-	-	-	-	
Basic (V20 and later)	No	No	No	Yes	No	Yes
Basic (V19 and earlier)	No	No	No	No	No	-
Tracking	No	Yes	No	Yes	Yes	Yes
Point-to-Point	Yes	No	Yes	No	No	Yes
Constant Speed	No	Yes	No	Yes	No	Yes

(1) If you set the type to Custom, you can control the individual gain calculations by changing the bit settings in the Gain Tuning Configuration Bits Attribute.

TIP Application Type defines the servo loop configuration automatically. These combinations determine how the calculations are made, which can reduce the need to perform an Autotune or a Manual Tune. For information about other attribute calculations, see the specific attribute description in the Integrated Motion on the EtherNet/IP Reference Manual, publication [MOTION-RM003](#).

- Choose a Loop Response, if applicable.
- If you have already created an axis and associated it with a drive, the Associated Module and Axis are shown on the General page of the Axis Properties dialog box. If not, you can select them here.
- The Axis Number field corresponds to the axes listed on the Associated Axes tab of the Module Properties dialog box. Any option module port assignments that you made on the Associated Axes tab are also mapped to the drive when you associate an axis and a drive.
- Click Apply to save changes.

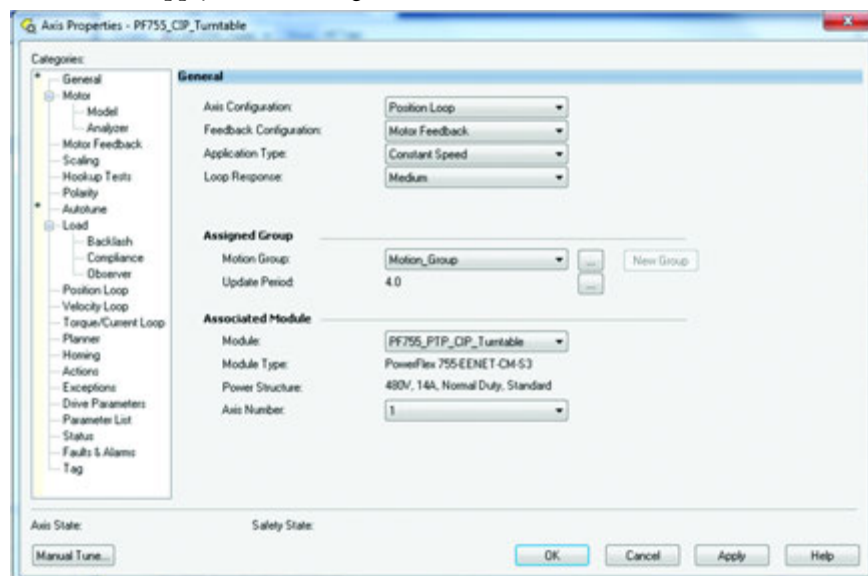

Specify the Motor Data Source

The Motor Data Source is where you tell the axis where the motor configuration values are originating. You can select a motor from the database, nameplate, or nonvolatile memory. The nameplate option requires that you enter the motor specification information. You can find the information on the hardware nameplate or product data sheets.

1. Double-click on the axis (PF755_CIP_Turntable) to open the Axis Properties dialog box.
2. Choose the Motor page.
3. Enter the motor data recorded during [Prepare for Initial Drive Start Up on page 50](#). Rotary Permanent Magnet and Rotary Induction are supported.

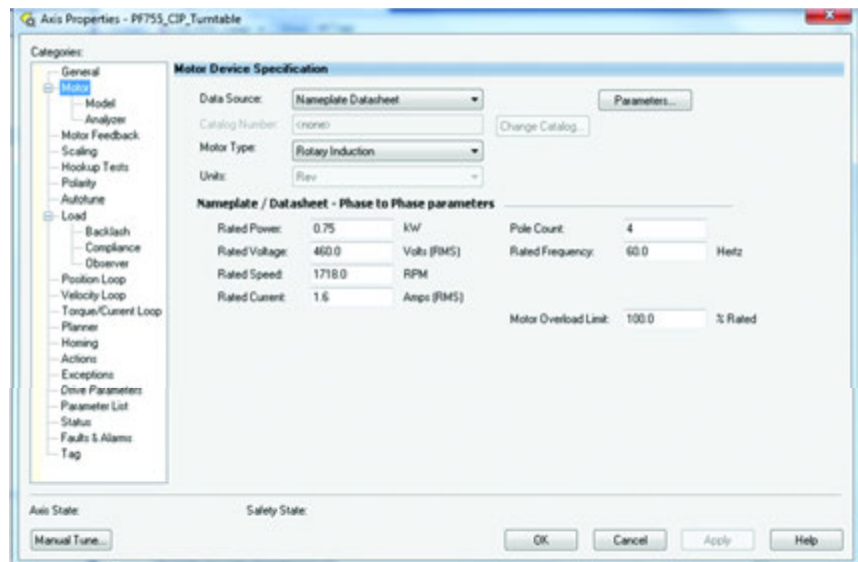

4. Click Apply.
5. Choose the Motor Feedback page.

6. Choose the Type of the encoder mounted and wired to the drive.
In our example, we use a Hiperface encoder with 4096 Turns.

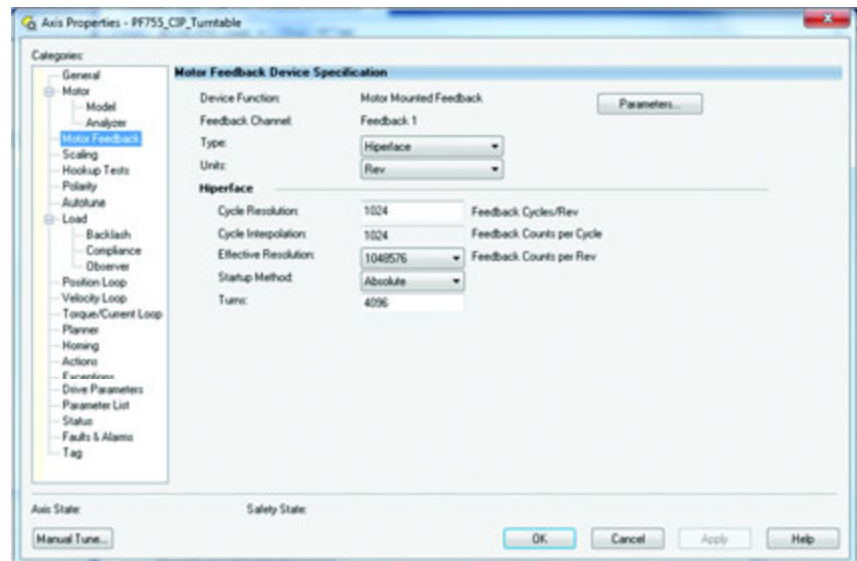

7. Click Apply.
8. Choose the Scaling page.
9. Choose the Load Type.

In our example, we use a turntable with no gear ratio, so the type is Direct Rotary Coupled.

10. Enter the Scaling units used to program.

In our example, we use degrees.

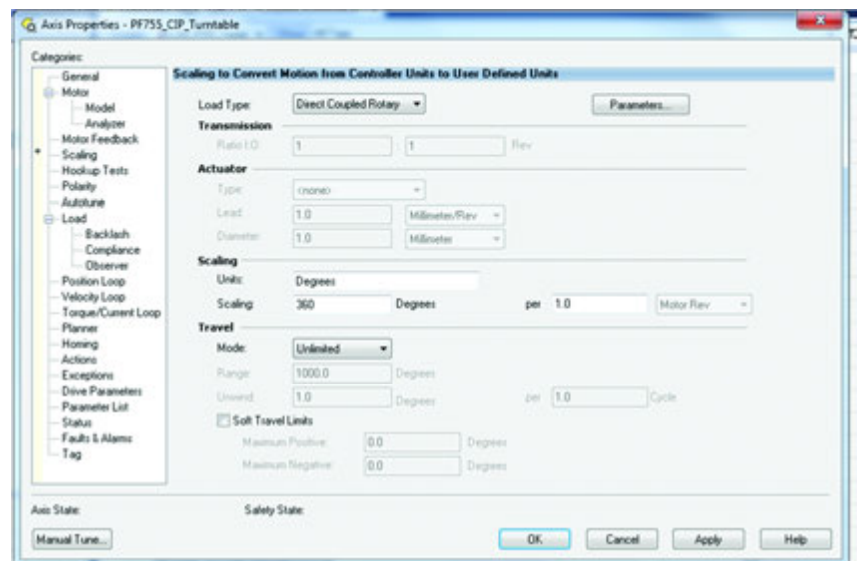

- Click Apply to save changes. The following dialog box appears.

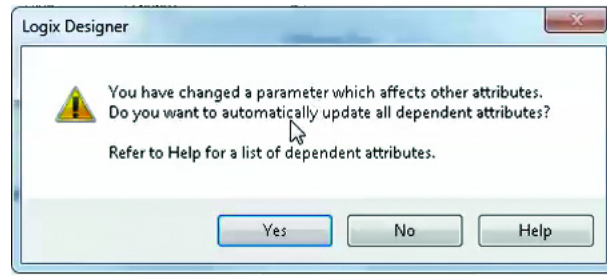

- Click Yes.
- Choose the Planner page to enter system limits.
- Set the values as desired for the application.

See information from [Prepare for Initial Drive Start Up on page 50](#) for more information.

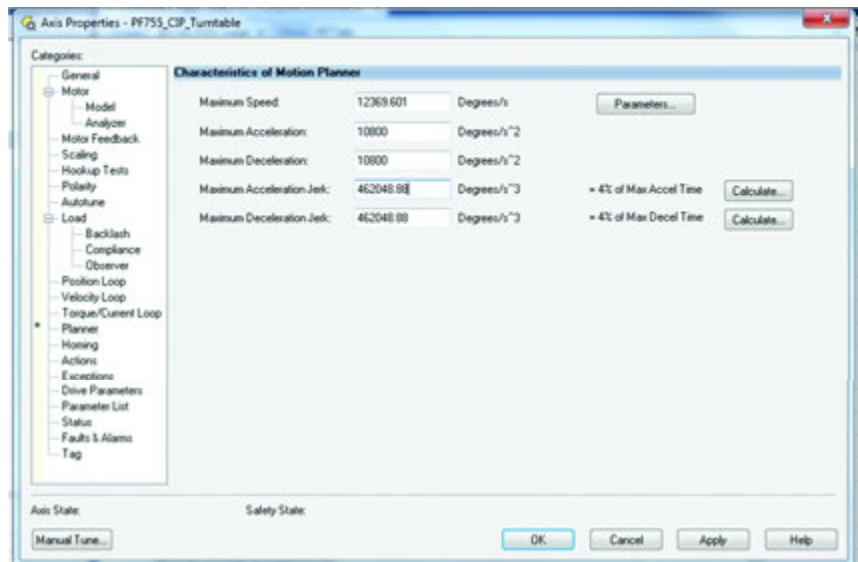

- Click Apply.
- Choose the Homing page.
- Set the values as desired for the application.

In our example, we use Passive which means the PLC will take the present position and log it as 0 degrees.

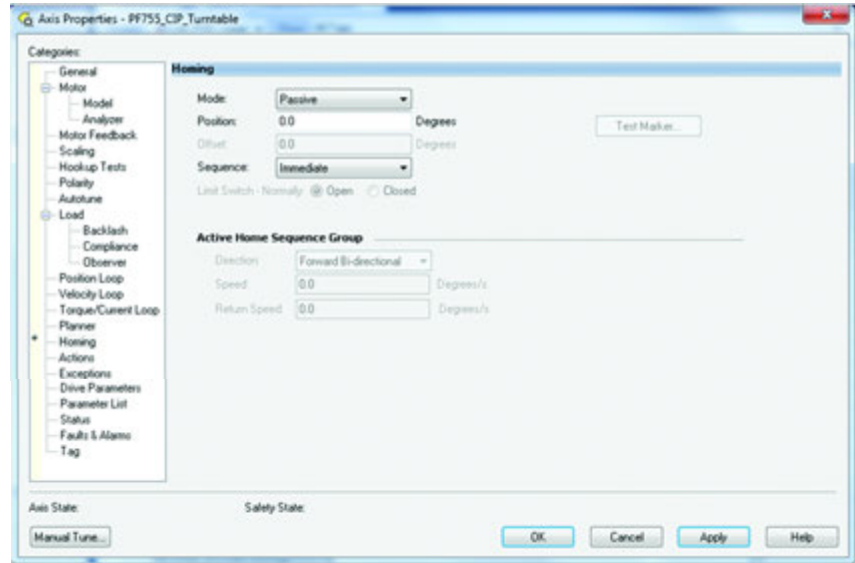

18. Click Apply.
19. Choose the Actions page.
20. For the S3 option module, set the values as desired for the application.

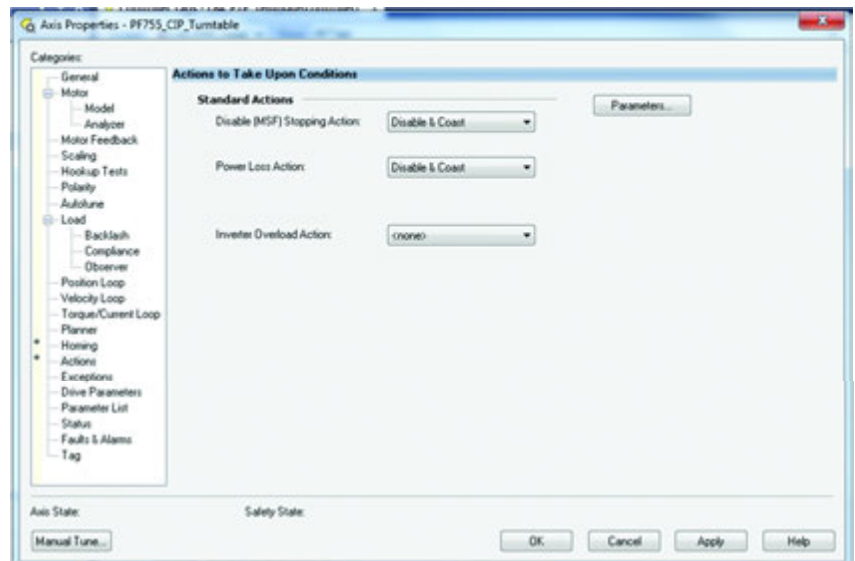

- For the SSM and S4 option modules refer to the PowerFlex 755/755T Integrated Safety Functions Option Module (S4), publication [750-UM005](#) for recommendations on specific applications.

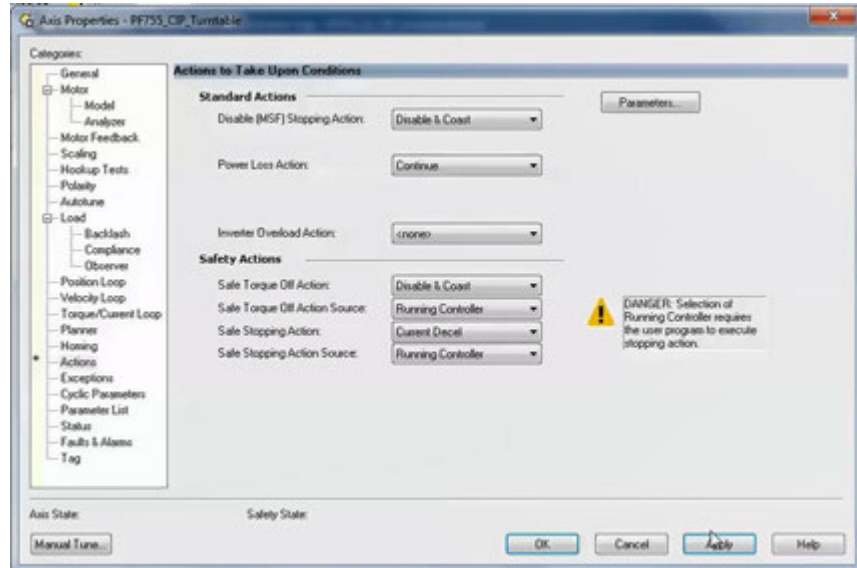

TIP In SSM and S4 option modules, the Drive Parameters page is labeled Cyclic Parameters.

21. Click Apply.
22. Choose the Drive Parameters page for S3, or Cyclic Parameters for SSM and S4.
23. Select the drive parameters for controller mapping to read and write to the drive.

A maximum of 10 parameters can be selected. We have selected those that are recommended.

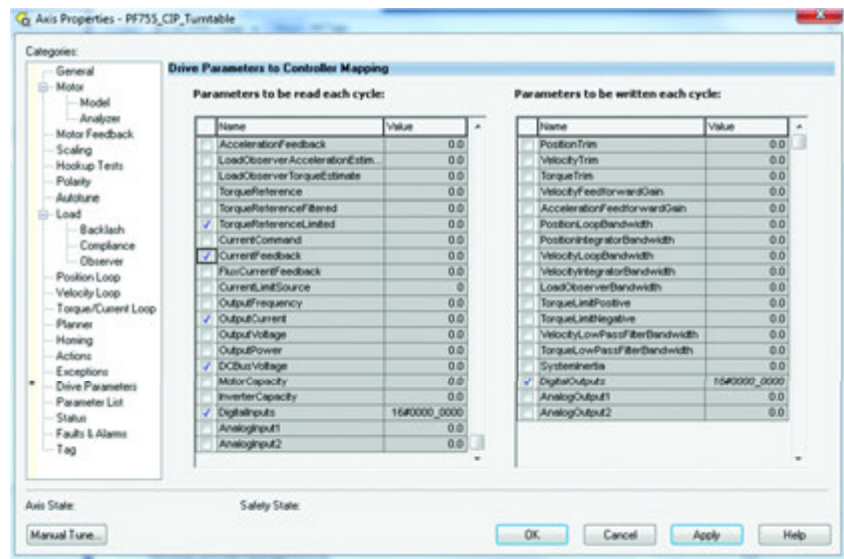

24. Click Apply.

25. Click OK to close the Axis Properties dialog box.

Create a Safety Program to Control the Drive Safety Circuits

1. Select MainRoutine from the Controller Organizer.

The safety program ladder logic dialog box opens.

2. Use the ladder logic editor tools to edit the main routine to create the desired safety program.

In our example we used the Safe Torque Off (S3) safety option module.

TIP For the safety program and manual creation of ladder logic in the SSM and S4 option modules, there are more options than what exist for the S3 module. In this configuration, Motion Direct commands are used and no additional ladder logic is required.

For more information on using ladder logic, refer to Logix 5000 Controllers Ladder Diagram Programming Manual, publication [1756-PM008](#). This manual shows how to program Logix 5000 controllers with the relay ladder programming language. This manual is one of a set of related manuals that show common procedures for programming and operating Logix 5000 controllers. For a complete list of common procedure manuals, refer to the Logix 5000 Controllers Common Procedures Programming Manual, publication [1756-PM001](#).

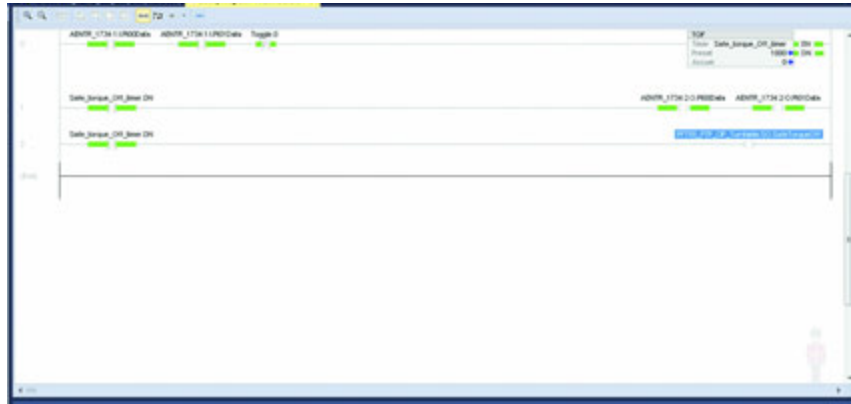

Save and Download the Project

After all axis properties and option module values have been set for your application, save the program, and then download it into the Logix controller. For this procedure, leave the controller in Remote Program Mode.

1. From the File menu, select Save As to save the file in an appropriate location for your application.

- From the Communications menu, select Who Active to open RSLinx.

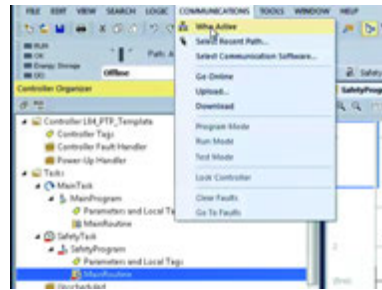

- On the Who Active dialog box, expand the tree under the appropriate EtherNet/IP driver to show the available controllers.
- Select your target controller.

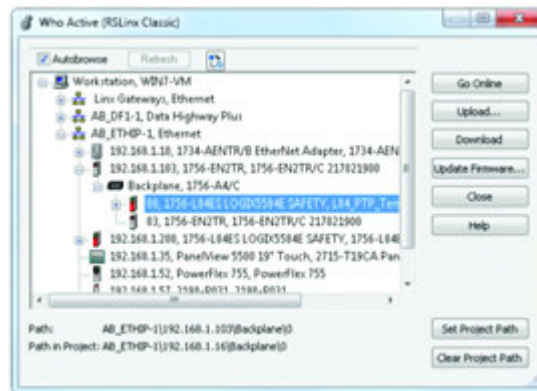

- Click Download.
- The controller status switches from offline to online.
- When the Download dialog box appears, click Download.



- Click No on the dialog box that asks to switch into Remote Run.

The controller must be in Program Mode to finish the startup configuration.

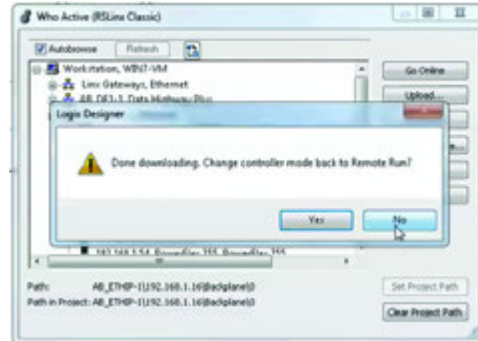

TIP For SSM and S4 option modules:

Click Yes to put the drive in Remote Run, and allow the drive and controller to automatically sync. Then, use ladder logic to turn STO on.

During download the controller switched from Offline to Remote Program mode. Selecting No to Remote Run allows you to stay online in Remote Program mode without putting the controller into Run Mode.

Verify the Controller Is Online

When going online to the controller, the Logix processor connects and downloads the parameter settings to the PowerFlex 755 drive. You can observe connecting, configuring, and syncing from the HIM mounted on the front cover of the drive.

After the synchronization is complete, the yellow triangle next to the drive should disappear from the drive listed under the Ethernet network in the I/O Configuration. The status can be seen in the lower left panel.

For troubleshooting information about going online see [Chapter 6 Troubleshooting on page 173](#).

1. Open the Module Properties dialog box to verify that the drive is online.
2. If Rem Prog is in the status field, the controller is online.

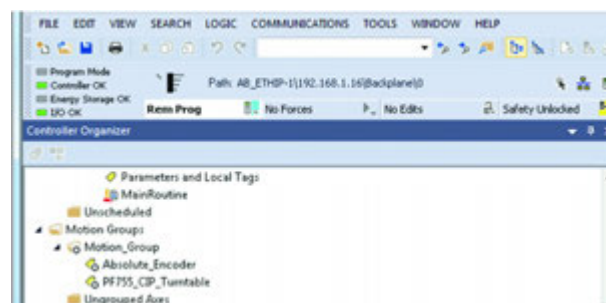

Commission and Tune the Motor and Drive

You need to tune the motor so that the PowerFlex 755 drive knows how to control it properly.

TIP If at any point during the commission and tuning, an error is encountered related to the drive, open the drive Module Properties dialog box and review the pages to find and correct the error. The yellow triangle indicates an error.

1. Under the Motion Group in the project tree, double-click the axis to commission, to open the Axis Properties dialog box.



2. From the Axis Properties dialog box, expand the Motor tree, and choose the Analyzer page.

In our example, the motor is uncoupled.

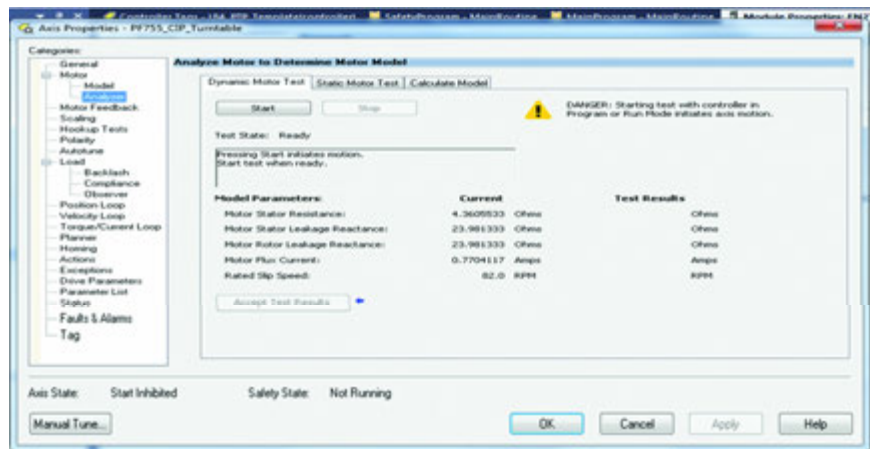

Static Motor Test

1. From the Analyzer page, choose the Static Motor Test tab.
The following message is displayed.

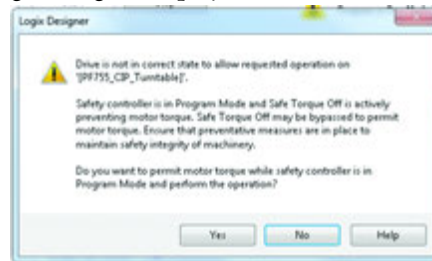

ATTENTION: Because the drive has a integrated safety option module and it is not enabled, there is an option to allow motor torque while the controller is in Program mode. Click Yes only if it is safe to rotate the motor. Failure to comply could result in equipment or personal injury.

2. If Safety has been enabled, click Start to initiate the Static Motor Test.

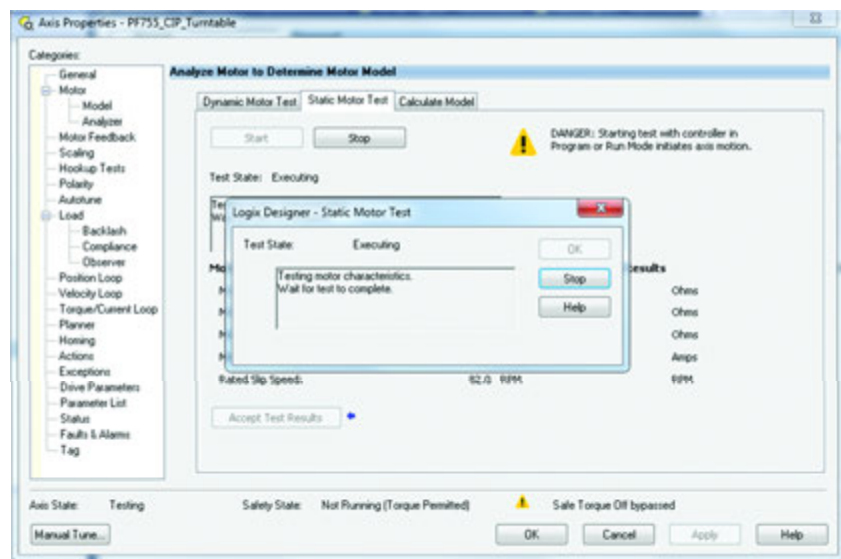

3. After the Static Motor Test is complete, click OK.
4. Click Accept Test Results to move the results into the Logix controller properties.



Dynamic Motor Test

If the motor is uncoupled, perform a Dynamic Motor Test.

This test is similar to the Static Motor test, however, instead of calculating the Motor Flux Current from a look up table, it causes the motor to rotate at approximately 80% of the Motor Nameplate speed to determine the actual Motor Flux Current required to rotate the motor with no load attached.

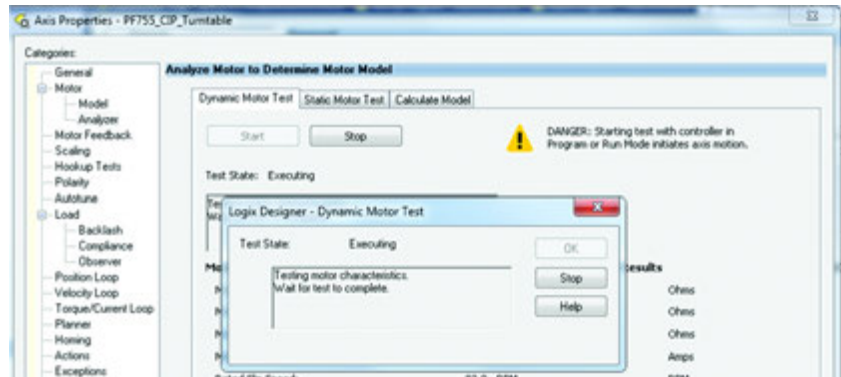

1. From the Analyzer page, choose the Dynamic Motor Test tab.
2. Click Start to run the test.
3. After the Dynamic Motor Test is complete, click OK.
4. Click Accept Test results to move the results into the Logix controller properties.



Motor and Feedback Test

1. On the Axis Properties dialog box, choose the Hookup Tests page.
2. Enter a value in the Test Distance field.
In our example, we use 10,000 degrees.
3. Click Start to run the Motor and Feedback Test to verify that the encoder and motor are wired properly and have synchronized directions.

4. After the test is complete, click OK.

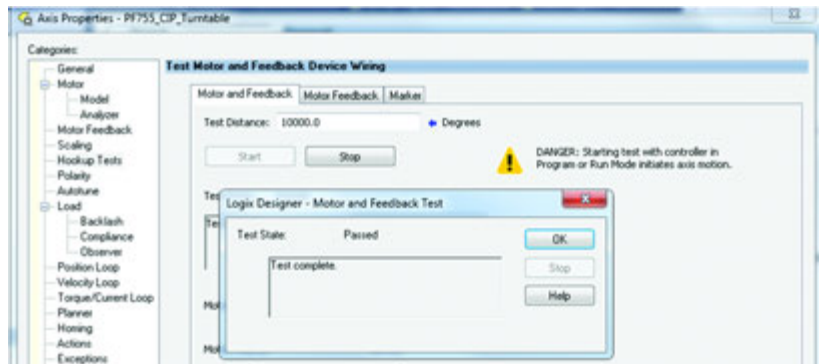

5. If the motor rotated in the proper direction, click Yes.

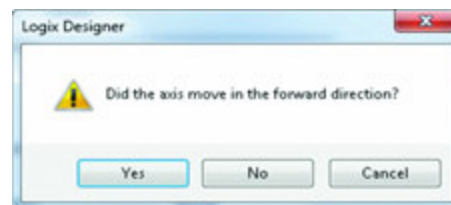

6. If the answer is No, see [Motor Polarity on page 141](#).

Motor Polarity

If the motor did not rotate in the anticipated direction during the Motor and Feedback Test, choose the Polarity page to correct the polarity.

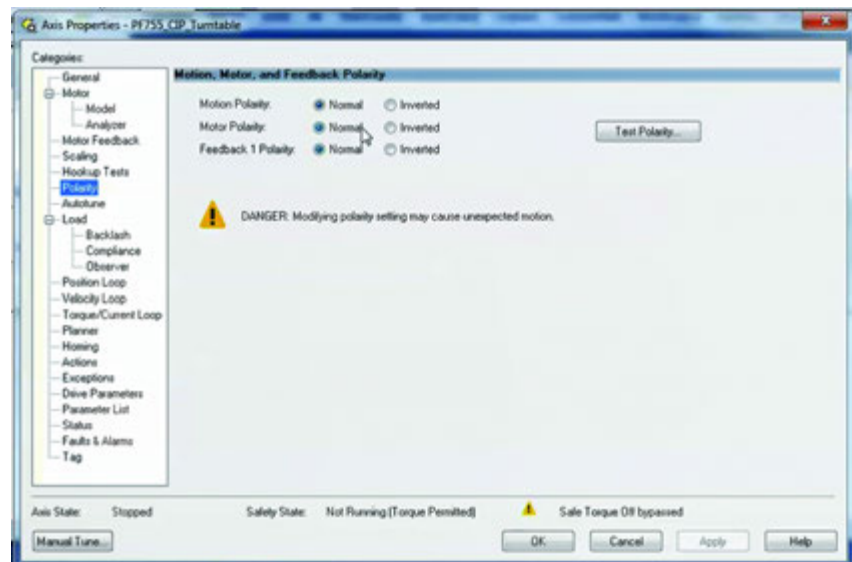

Autotune

After the Motor and Encoder feedback tests are complete, you must Autotune the application velocity and position loops. See [Application Notes on page 111](#) for more information related to position loop setup.

1. From the Axis Properties dialog box, choose the Autotune page.
2. Enter the allowable Travel, Speed, Torque, and Direction limits.
Refer to [Prepare for Initial Drive Start Up on page 50](#) for more information.
3. Click Start to initiate the test.

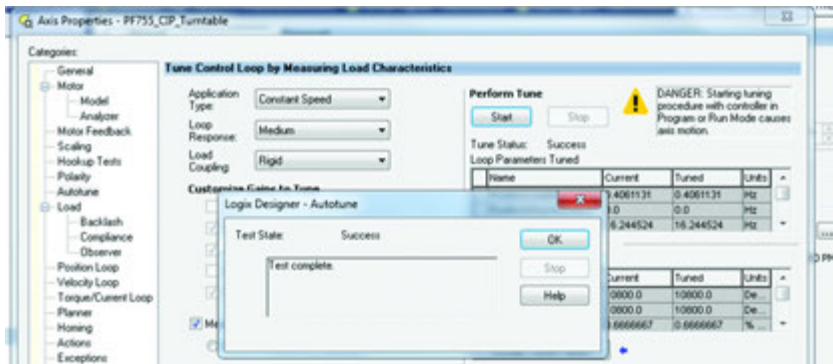

4. After the Autotune Test is complete, click OK.
5. Click Accept Tuned Values to move the results into the Logix Controller properties.

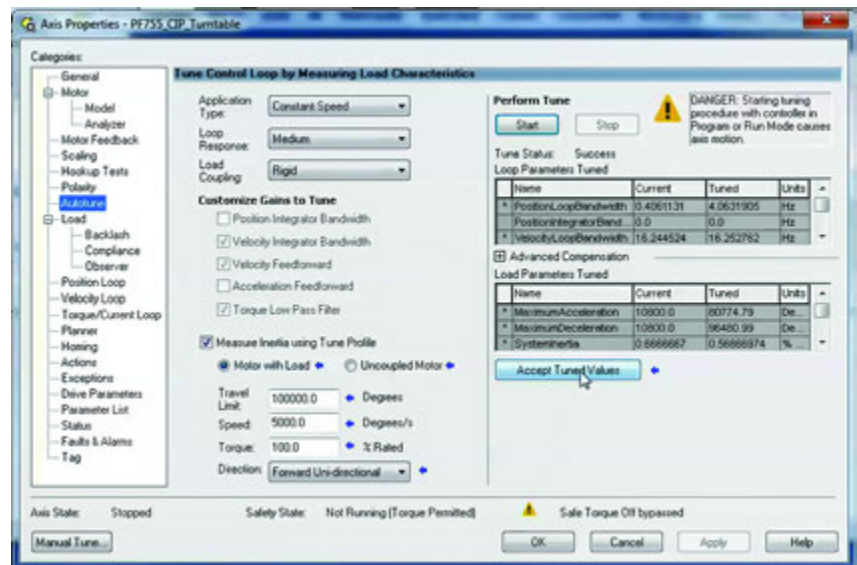

Manual Tune

If you want to manually tune the PowerFlex 755, choose Manual Tune to access the Position and Velocity loop tuning values. You also have the ability from this dialog box to issue Motion commands to cause the axis to move as desired. (Motion Servo On, Motion Axis Stop, Motion Servo Off, Motion Axis Jog, and so on.) Use RS Trend to observe the performance of the PowerFlex 755 and adjust tuning parameters until a desirable response is obtained.

1. From the Axis Properties dialog box, choose the Autotune page.
2. Click Manual Tune from the lower left corner of the Axis Properties screen.
3. Enter the allowable Travel, Speed, Torque, and Direction limits. Refer to [Prepare for Initial Drive Start Up on page 50](#) for more information.

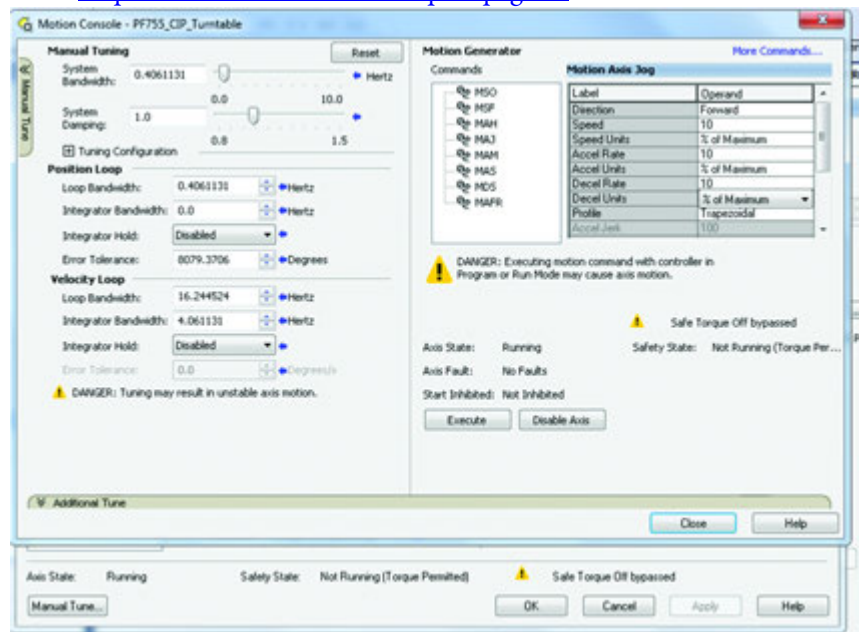

4. Adjust the System Bandwidth and System Damping.
5. Enter the information for the Position and Velocity loop.
6. Select the Motion Axis Jog commands.
7. Click Execute.
8. When the Manual Tune test is complete, click OK.
9. Click Close to close the Manual Tune screen.
10. Click OK to close the Axis Properties dialog box.

Save Commissioned Axis to the Logix Project

At this point, start up and configuration are complete and you can save and upload the configuration to allow the drive to run.

1. Save the project.
2. Click Yes.

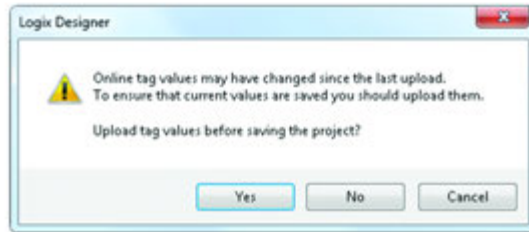

3. The project uploads automatically to the location that was mapped in [Save and Download the Project on page 135](#).
4. Write and test your Logix application code to verify that the PowerFlex 755 performs as desired.

Commissioning of the PowerFlex 755 axis is complete. For more information on using ladder logic, refer to Logix 5000 Controllers Ladder Diagram Programming Manual, publication [1756-PM008](#).

Drive Maintenance

Topic	Page
Repair and Replacement Procedures	146
Remove Power	147
Remove the Front Cover	148
Replace the Surge Suppressor AC Source Brake (1SUP270)	150
Replace the DC Brake Surge Suppressor (1BD0270)	151
Replace the Brake Contactor (5BC130)	152
Replace the Main Circuit Breaker (1CB030)	153
Replace PowerFlex Frame 2 Drive (1EA030)	156
Replace the Auxiliary Circuit Breakers (5CB070 and 1CB250 or 5CB130)	161
Replace the Drive HIM (1HIM320)	162
Replace the EMC Kit (1CH030)	163
Replace the ETAP Module (6ET210)	163
Replace Receptacles on the Gland Plate	164
Attach the Front Cover	169
Apply Power	170



ATTENTION: If any component is removed, replaced, or adjusted, the On-Machine Drive must **go through the entire start up procedure** to verify proper configurations and settings. Failure to do so could cause equipment damage or failure.

IMPORTANT Only open the front cover of the enclosure if you suspect the components inside are damaged.

Repair and Replacement Procedures

The following table displays which maintenance topics are covered in this manual. When a component has specific instructions on repair or replacement, a link to that component instructions is provided.

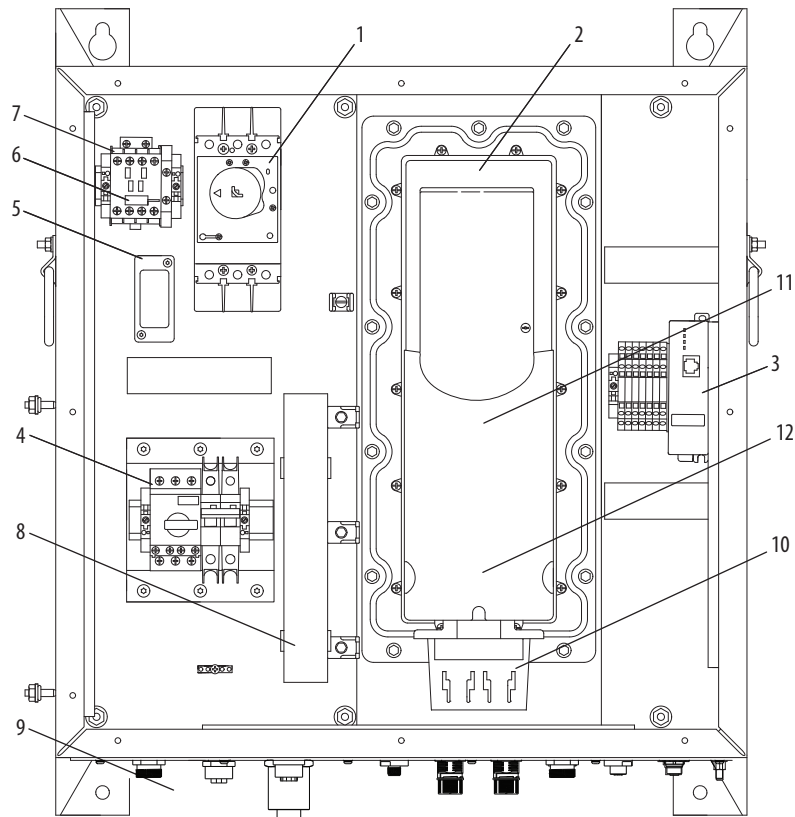

Ref. No.	Component	Repairable / Replaceable?	Topic Covered In
	Power	No	Remove Power on page 147 Apply Power on page 170
	Front Cover (not shown)	No	Remove the Front Cover on page 148 Attach the Front Cover on page 169
1	Main Circuit Breaker	Yes	Replace the Main Circuit Breaker (1CB030) on page 153
2	Human Interface Module (HIM)	Yes	Replace the Drive HIM (1HIM320) on page 162
3	Ethernet Tap	Yes	Replace the ETAP Module (6ET210) on page 163
4	Auxiliary Circuit Breakers ⁽¹⁾	Yes	Replace the Auxiliary Circuit Breakers (5CB070 and 1CB250 or 5CB130) on page 161
		No	Open Auxiliary Circuit Breaker Door on page 176
5	Surge Suppressor AC Source Brake ⁽²⁾	Yes	Replace the Surge Suppressor AC Source Brake (1SUP270) on page 150
6	Surge Suppressor DC Brake ⁽²⁾	Yes	Replace the DC Brake Surge Suppressor (1BD0270) on page 151
7	Brake Contactor - (upper left)	Yes	Replace the Brake Contactor (5BC130) on page 152
8	Common Mode Core	No	-
9	Receptacles (bottom)	Yes	Replace Receptacles on the Gland Plate on page 164
10	EMC Kit	Yes	Replace the EMC Kit (1CH030) on page 163
11	Drive Heatsink and Fan (behind drive)	Yes	Replace the PowerFlex Frame 2 Heatsink Fan on page 160
12	PowerFlex [®] 755 Frame 2 Drive	Yes	Replace PowerFlex Frame 2 Drive (1EA030) on page 156

(1) The brake circuit breakers vary in design and operation based on the configurations of 24V DC mechanical brake or 400/480V AC source mechanical brake.

(2) The configuration has either AC or DC brake.

Remove Power

1. Rotate the red disconnect handle counter-clockwise to the OFF position.
2. Use a **flat-head screwdriver** to rotate the locks counter-clockwise to open the auxiliary circuit breaker door on the front cover.
3. Verify that all breakers are in the OFF position.



WARNING: Circumstances that can cause an explosion may exist, which may lead to personal injury or death, property damage, or economic loss. If the branch circuit protection device trips, you must use the software to verify that the source brake function is still operational before putting the equipment back in service. If the source brake function is not working properly, loss of brake function or motor damage can occur.



ATTENTION: Do not operate controls or open covers without appropriate personal protective equipment. Verify that all incoming power is disconnected and discharged before removing the cover.

4. Disconnect the upstream power source and perform lock out / tag out on the upstream 400/480V AC.

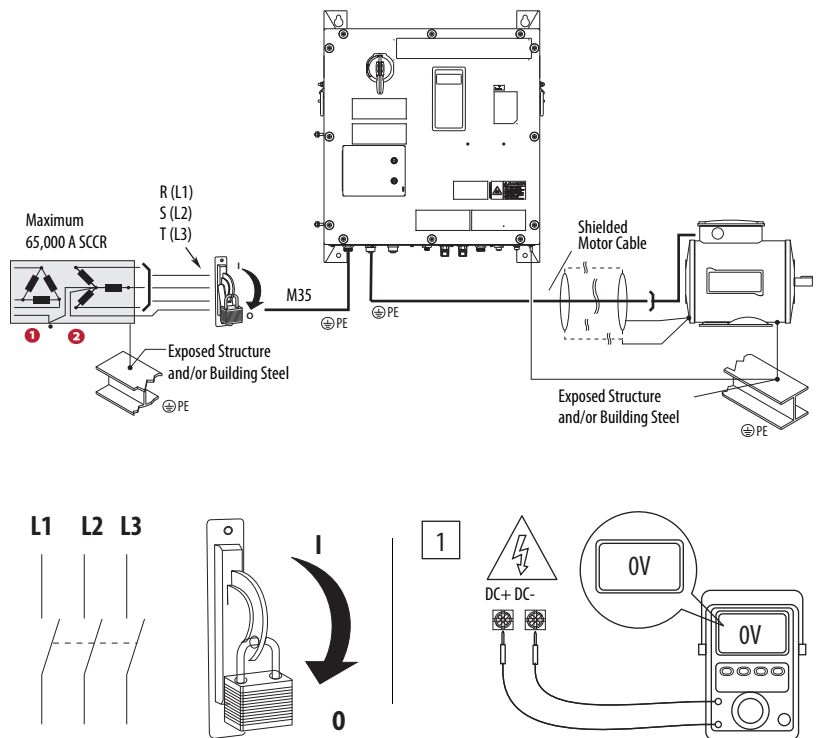

IMPORTANT This lock out / tag out is only for upstream power. During initial installation, the On-Machine™ Drive does not have power. The breakers should be in the OFF position when the unit arrives. Verify that all breakers are off before installation is started. For more information, see the [Circuit Breakers on page 24](#).

5. Disconnect all power connections from the receptacles from the gland plate on the bottom of the drive.



ATTENTION: Failure to observe this warning can result in machine damage or personnel injury. Remove power from the drive system and wait for the voltage on the bus to discharge before removing the cover or performing any work on the drive.



SHOCK HAZARD: The drive contains high voltage that takes time to discharge after removal of the main supply. Before working on the drive, isolate the main power supply from line inputs (L1, L2, L3). Wait 3 minutes for the system to discharge to minimal voltage levels. Failure to do so may result in personal injury or death.

Remove the Front Cover

IMPORTANT When the unit is mounted in the proper orientation, the removal of the cover requires two people.

1. Follow the procedure to [Remove Power on page 147](#).
2. Verify that the rotary disconnect is in the OFF position.
3. Verify that the auxiliary circuit breakers are in the OFF position.
4. Use a **T30 torque bit** to remove the 12 screws and washers from the front cover.

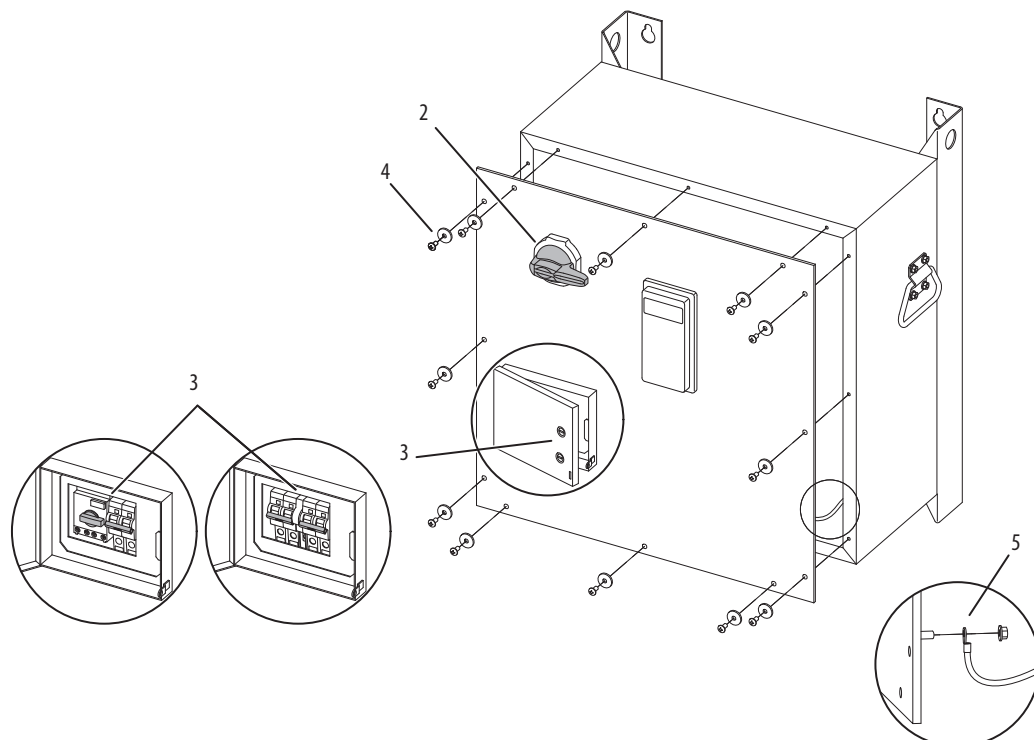

IMPORTANT The HIM and ground cable determine how far the cover can be rotated and lifted. These must be disconnected before the cover can be completely removed.

5. Lift the cover up approximately 2 inches and turn the cover over, this motion is similar to how you would turn a page.
 - a. Use a **10 mm** wrench to disconnect the ground nut on the back side of the cover. Remove the grounding wire from the stud and then reattach the ground nut.
 - b. To remove the front cover on the drive, squeeze the sides as indicated on the drive, and lift.

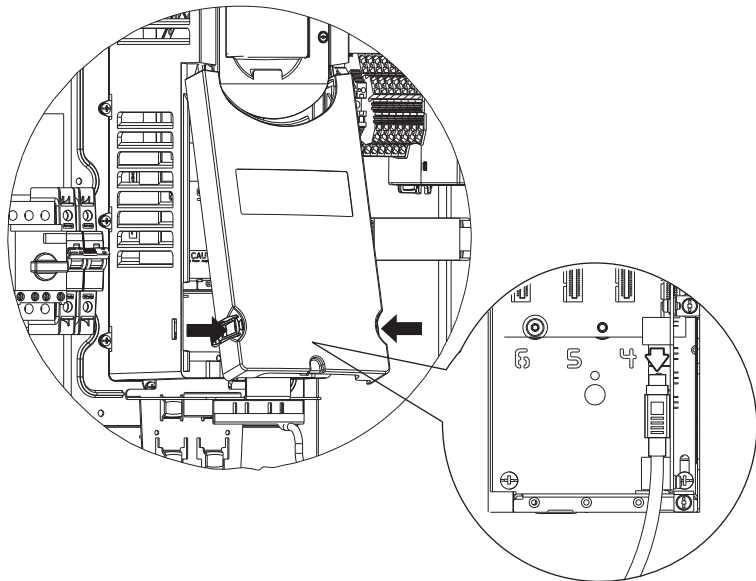

- c. Disconnect the HIM cable from the drive, and free the HIM cable to allow the front cover of the drive to be removed.
 - d. Reattach the drive cover.
6. Set the front cover aside.

Replace the Surge Suppressor AC Source Brake (1SUP270)

TIP The AC source brake surge suppressor is only available in the 400/480V AC source brake option. It is not available in the 24V DC brake option.

1. Follow the procedure to [Remove Power on page 147](#).
2. Follow the instructions to [Remove the Front Cover on page 148](#).
3. Use a **Phillips screwdriver** to disconnect wires **T1** and **T2** from the brake contactor.
4. Use a **T20 torque bit** to remove the two torque screws that hold the surge suppressor in place.
5. Remove the surge suppressor.

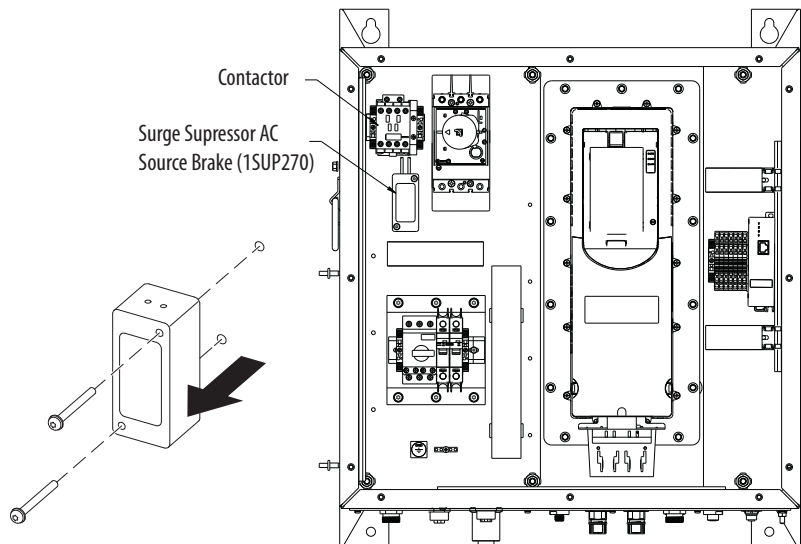

6. Unpack and inspect the new surge suppressor AC source brake.
7. Connect the wires to terminals **T1** and **T2** on the brake contactor.
Torque screws to **15 lb•in.**
8. Use the two existing screws and the **T20 torque bit** to secure the surge suppressor to the enclosure.
Torque screws to **15 lb•in.**
9. Follow the instruction to [Attach the Front Cover on page 169](#).

Replace the DC Brake Surge Suppressor (1BD0270)

TIP The DC brake surge suppressor is only available in 24V DC mechanical brake option. It is not available in a source brake option.

1. Follow the procedure to [Remove Power on page 147](#).
2. Follow the instructions to [Remove the Front Cover on page 148](#).
3. Use a **flathead screwdriver** to disconnect the wires from the DC brake surge suppressor on the output side of the brake contactor.

Wire Description	Terminal Number
5BC130-T1 (From Surge Suppressor '+')	T1 (of 5BC130)
5BC130-T2 (From Surge Suppressor '-')	T2 (of 5BC130)

4. Slide the surge suppressor out of the front of the brake contactor.

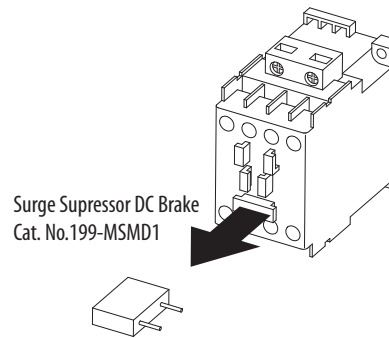

5. Unpack and inspect the new surge suppressor DC brake.
6. Insert the surge suppressor into the brake contactor with the text upright.
7. Use a **flathead screwdriver** to connect the wires in [step 3](#) to the output side of the brake contactor.
Torque screws to **15 lb•in.**
8. Follow the instructions to [Attach the Front Cover on page 169](#).

Replace the Brake Contactor (5BC130)

1. Follow the procedure to [Remove Power on page 147](#).
2. Follow the instructions to [Remove the Front Cover on page 148](#).
3. Use a **flathead screwdriver** to disconnect the wire from the input and output sides of the brake contactor

Location	Wire Description	Terminal Number
Top	5BC130-L1	L1
	5BC130-L2	L2
	5BC130-13	13
	5BC130-A1	A1
	5BC130-A2	A2
	5BC130-21 ⁽¹⁾	21
Bottom	5BC130-T1 (From Connector)	T1
	5BC130-T1 (From Surge Suppressor)	T1
	5BC130-T2 (From Connector)	T2
	5BC130-T2 (From Surge Suppressor)	T2
	5BC130-14	14
	5BC130-22 ⁽¹⁾	22

(1) Only applicable to Safety option 'C'

4. Use **flathead screwdriver** to loosen the 2 screws from the end anchors that secure the brake contactor to the enclosure.



ATTENTION: Use caution when removing the service contactor from DIN rail. Failure to use caution could result in personal injury or equipment damage.

5. Use a **screwdriver** to dislodge the brake contactor from the DIN rail.

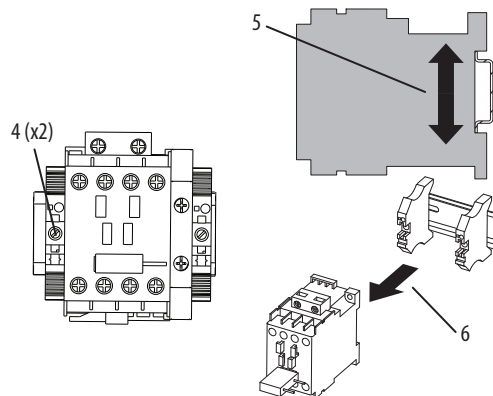
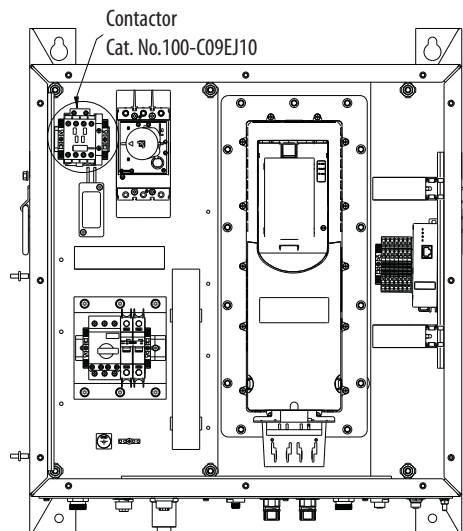

6. Remove the brake contactor from the cabinet.

7. Unpack and inspect the new brake contactor.
8. Attach the brake contactor to the DIN rail.
9. Use a **flathead screwdriver** to tighten the two screws on the end anchors.

Torque screws to **4.4 lb•in.**

10. Use the **flathead screwdriver** to connect the **wires/terminals** to the brake contactor according to the table in [step 3](#).

Torque screws to **15 lb•in.**

11. Follow the instructions to [Attach the Front Cover on page 169](#).

Replace the Main Circuit Breaker (1CB030)

Circuit Breaker Description	Catalog Number
400/480V AC main power	140G-G6C3-C30-AJ
Rotary disconnect with door handle	140G-G-RVM12R

1. Follow the procedure to [Remove Power on page 147](#).
2. Follow the instructions to [Remove the Front Cover on page 148](#).
3. Use a **#5 hex key** to remove the wires from the input and output side of the main circuit breaker.

Wire Description	Terminal Number
1CB030-L1	L1
1CB030-L2	L2
1CB030-L3	L3
1CB030-T1 (from 1EA030-R/L1)	T1
1CB030-T1 (from 1CB250-1) ⁽¹⁾	T1
1CB030-T2 (from 1EA030-S/L2)	T2
1CB030-T2 (from 1CB250-5) ⁽¹⁾	T2
1CB030-T3 (from 1EA030-T/L3)	T3
TB2-4	Connect 21 to TB2-4 Load side
1CB250-13 ⁽¹⁾	Connect 24 to 1CB250-13
5CB130-11 ⁽²⁾	Connect 24 to 5CB130-11

(1) Only applicable to Brake option 'SB'

(2) Only applicable to Brake option 'B2' and 'B3'

4. Use a **Phillips screwdriver** to remove the two screws that fasten the main circuit breaker to the enclosure.

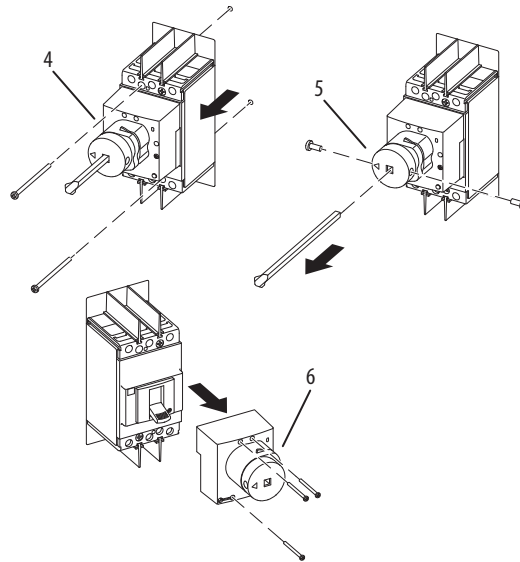

5. Use a **Phillips screwdriver** to remove the two screws that hold the circuit breaker shaft in the main circuit breaker assembly.
6. Use a **miniature Phillips screwdriver** to remove the three screws from the rotary mechanism of the main circuit breaker.

This separates the circuit breaker from the internal rotary mechanism of the main circuit breaker.

7. Use a **T20 torque bit** to remove the two screws that connect the rotary disconnect switch to the front cover.

TIP If the rotary disconnect switch is not damaged, it is not required to replace the switch on the front cover.

8. Unpack and inspect the new main circuit breaker and / or rotary mechanism.
9. Use the three **M3 x 36 mm** screws and the **miniature Phillips screwdriver** to attach rotary mechanism of the main circuit breaker to the circuit breaker.
Torque screws to **9.73 lb•in.**
10. Use the two supplied screws and the **Phillips screwdriver** to attach the circuit breaker shaft to the main circuit breaker assembly.

Torque screws to **9.73 lb•in.**

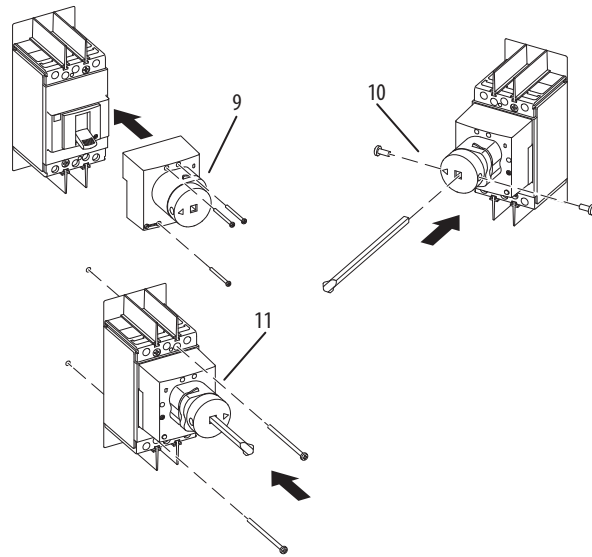

11. Use the two **M4 x 73 mm** screws and the **Phillips screwdriver** to attach the main circuit breaker to the enclosure.

Torque screws to **25 lb•in.**

12. Use the **#5 hex key** to attach the wires/terminals listed in [step 3](#) to the main circuit breaker.

Torque screws to **62 lb•in.**

TIP If step [7](#) was performed, use two **0.25-20 mm** screws and the **T20 torque bit** to attach the rotary disconnect switch to the front cover.

Torque screws to **25 lb•in.**

13. Follow the instructions to [Attach the Front Cover on page 169](#).

Replace PowerFlex Frame 2 Drive (1EA030)



1. Follow the procedure to [Remove Power on page 147](#).
2. Follow instructions to [Remove the Front Cover on page 148](#).
3. Remove the front cover from the drive.
 - a. Squeeze the locking tabs and pull out the bottom of cover.
 - b. Pull the cover down and away from the chassis.

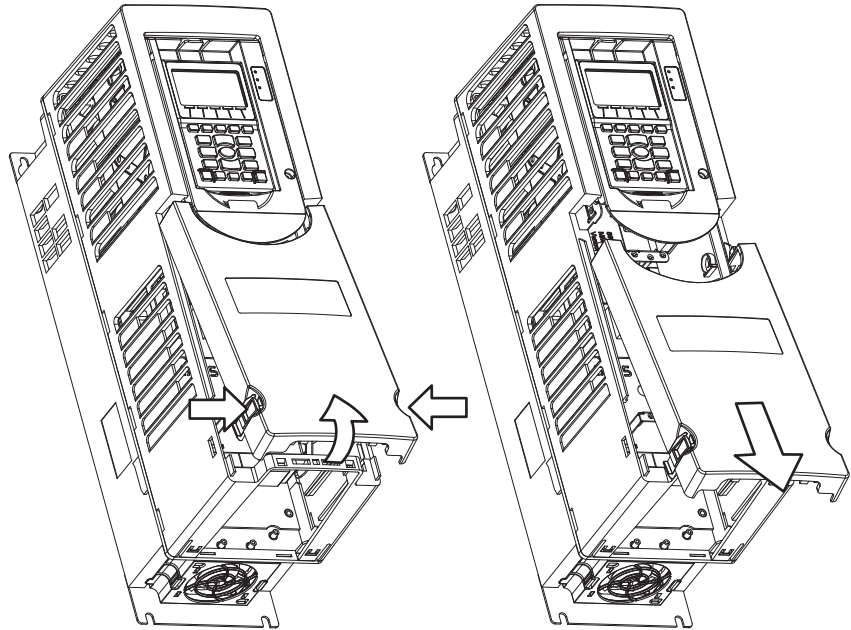

TIP Your model of the Frame 2 does not have a HIM mounted to the drive, the images that are used here are only for reference.

- c. Loosen the retention screw.
- d. Lift the cradle until the latch engages.

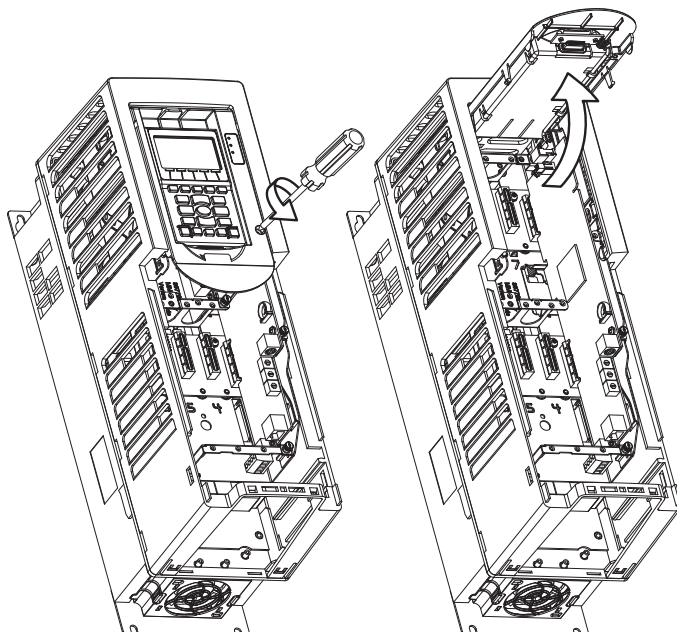

4. Disconnect the HIM cable.
5. Disconnect the Ethernet cable.
6. Without removing the control cables attached to the terminal blocks, detach the terminal blocks from the options modules located in **slots 4, 5, 6, 7, and 8.**

TIP To avoid the need to rewire the terminal blocks, verify terminal screws and wires are secure. Terminal wiring does not need to be removed to replace the PowerFlex 755 drive.

7. Place the removed option modules in anti-static bags.



ATTENTION: Note which slot each of the option modules was removed from. See [Replace Option Modules on page 160](#) for the list of possible option modules. Failure to record option module location could result in equipment failure, software incompatibility, start up problems, or other damage.

For information on repair or replacement of the options modules in the drive, see PowerFlex 750-Series Option Modules, publication [750-IN002](#) or PowerFlex 750-Series AC Drives, publication [750-IN001](#).



ATTENTION: This drive contains ESD (Electrostatic Discharge) sensitive parts and assemblies. Static control precautions are required when you install, test, service, or repair this assembly. Component damage can result if ESD control procedures are not followed. If you are not familiar with static control procedures, see an applicable ESD protection handbook.

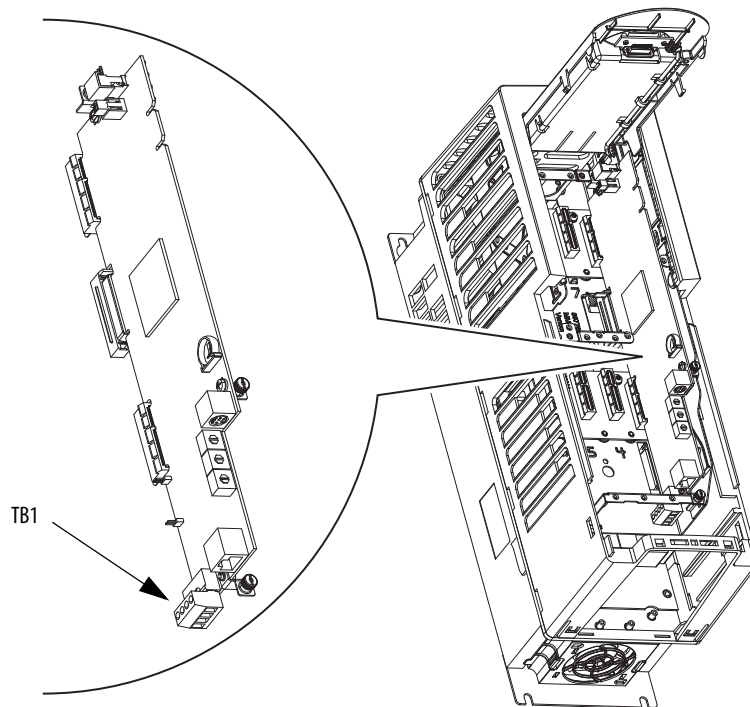

8. Without removing the control cables attached to the TB1 terminal block, disconnect the **TB1** terminal block from the main control board.

TIP To avoid the need to rewire the terminal blocks, verify terminal screws and wires are secure. Terminal wiring does not need to be removed to replace the PowerFlex 755 drive.

9. Use a #2 Pozidriv, M3 x 7 tool to remove the listed power wires.

Wire Description	Terminal Number
1EA030-R/L1	R/L1
1EA030-S/L2	S/L2
1EA030-T/L3	T/L3
1EA030-PE	PE (LEFT SIDE)
1EA030-U	U/T1
1EA030-V	V/T2
1EA030-W	W/T3
1EA030-PE	PE (RIGHT SIDE)
1EA030-BR1	BR1
1EA030-BR2	BR2

10. Use a 7 mm hex deep socket to remove the ground wires.
11. Remove the EMC kit. See [Replace the EMC Kit \(1CH030\) on page 163](#) for additional information.
12. Use a T20 torque bit to remove the 14 screws that hold the drive to the enclosure.

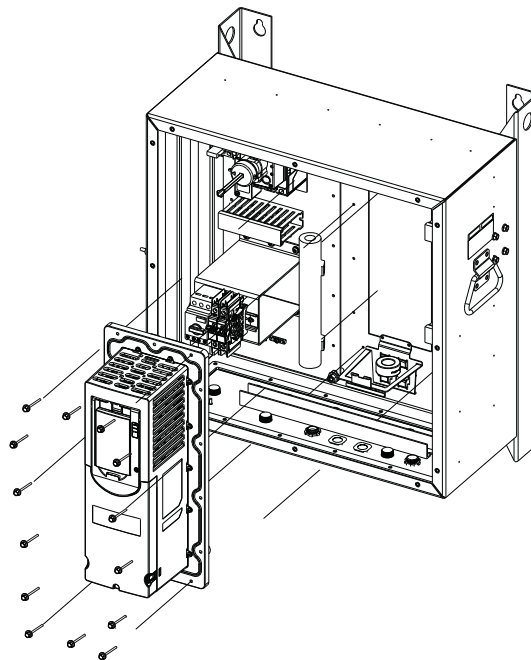

IMPORTANT In the image, the covers are shown in place, the covers must be removed and the terminal blocks disconnected to remove the drive.

For more information on repair or replacement of the drive, see PowerFlex 750-Series AC Drives Installation Instructions, publication [750-IN001](#).

TIP If you are replacing the drive heatsink fan, go to [Replace the PowerFlex Frame 2 Heatsink Fan on page 160](#) now. You can return to these steps after the heatsink fan has been replaced.

TIP If you are replacing option modules, go to [Replace Option Modules on page 160](#) now. You can return to these steps after the option modules have been replaced.

13. Unpack and inspect the new drive.
14. Use the 14 **10/16 x 1 1/4 in.** screws and **T20 torque bit** to attach the drive to the enclosure.
Torque screws to **25-30 lb•in.**
15. Refer to [step 3](#) to remove drive covers.
16. Attach the EMC Kit. See [Replace the EMC Kit \(1CH030\) on page 163](#) for additional information
17. Install the option modules into the same slots of the drive from which they were removed. See the electrical schematics and [Replace Option Modules on page 160](#) for more information.
18. Connect the terminal blocks to the applicable option modules.



ATTENTION: All terminal connectors should be fed through the bottom of the drive. Failure to properly route cables and connectors could result in personal harm or equipment damage.

19. Use a **#2 Pozidriv, M3 x 7** tool to connect all power wires listed in [step 9](#). Refer to the electrical schematics for more information.
Torque terminal screws to **5 lb•in.**
20. Use a **7 mm hex deep socket** to connect all ground wires.
Torque screws to **12 lb•in.**
21. Lower the faceplate and use a **flathead screwdriver** to tighten the two screws.
22. Attach the front cover of the drive.
23. Follow the instructions to [Attach the Front Cover on page 169](#).

Replace the PowerFlex Frame 2 Heatsink Fan

For information on repair or replacement of the drive heatsink fan, see PowerFlex 750-Series Fan Replacement Kits, publication [RA-IN027](#).

Follow the procedure to [Remove Power on page 147](#), follow instructions to [Remove the Front Cover on page 148](#), and follow the instructions to [Replace PowerFlex Frame 2 Drive \(1EA030\) on page 156](#) to gain access to the fan.

TIP In most cases, the majority of cables and wires routed into the Frame 2 drive can remain connected while replacing the heatsink fan.

Replace Option Modules

For information on repair or replacement option modules, see the PowerFlex 750-Series Option Modules, publication [750-IN002](#).

- Without removing the control cables attached to the terminal blocks, detach the terminal blocks from the options modules located in **slots 4, 5, 6, 7, or 8**.

TIP To avoid the need to rewire the terminal blocks, verify terminal screws and wires are secure. Terminal wiring does not need to be removed to replace option modules.

- Place the removed option modules in anti-static bags.



ATTENTION: Note which slot each of the option modules was removed from. Failure to record option module location could result in equipment failure, software incompatibility, start up problems, or other damage.

For information on repair or replacement of the option modules in the drive, see PowerFlex 750-Series Option Modules, publication [750-IN002](#) or PowerFlex 750-Series AC Drives, publication [750-IN001](#).

Option Module	Slot Assignment ⁽¹⁾	Variable Slot Assignments ⁽²⁾	Catalog Number	Reference Publication
PowerFlex-750 Series Encoder Option module	—	Slot 4	20-750-ENC-1	750-IN001
PowerFlex-750 Series Dual Encoder Option module	—	Slot 4	20-750-DENC-1	
PowerFlex-750 Series 24V DC Transistor I/O Option module	Slot 7	—	20-750-2263C-1R2T	
PowerFlex-750 Series Universal Feedback Option module	—	Slot 4 and/or Slot 5	20-750-UFB-1	
PowerFlex-750 Series Axillary Power Supply	Slot 8	—	20-750-APS	
PowerFlex-750 Series Network Safe Torque Off Option module	—	Slot 6	20-750-S3	750-UM004
PowerFlex-750 Series-Integrated Safety Function	—	Slot 6	20-750-S4	750-UM005

(1) This column can be used to record the physical slot assignment for the option modules.

(2) Slot assignment varies based on configuration option selected.

Replace the Auxiliary Circuit Breakers (5CB070 and 1CB250 or 5CB130)

The door seal on the auxiliary circuit breaker door is not replaceable, if the door seal is leaking or degraded below a level of acceptable function, a new front cover will need to be ordered.

Circuit Breaker Description	Catalog Number
400/480V AC source mechanical brake	140M-C2E-B25
Auxiliary Contact for Source brake CB	140M-C-AFA10
24V DC control power	1489-M2D040
24V DC mechanical brake	1489-M2D040
Auxiliary Contact for 24V DC brake CB	1489-AMRA3

1. Follow the procedure to [Remove Power on page 147](#).
2. Follow instruction to [Remove the Front Cover on page 148](#).
3. Use a **flathead screwdriver** to disconnect the wires from the breaker that needs to be replaced.

Breaker Type	Wire Description	Terminal Number
Source-brake auxiliary circuit breaker (1CB250)	1CB250-1	1
	1CB250-2	2
	1CB250-3	3
	1CB250-5	5
	1CB250-4	4
	1CB250-6	6
	1CB250-13	13
	1CB250-14	14
24V DC brake auxiliary circuit breaker (5CB130)	5CB130-1	1
	5CB130-3	3
	5CB130-2	2
	5CB130-4	4
	5CB130-11	11
	5CB130-14	14
24V DC control power auxiliary circuit breaker (5CB070)	5CB070-1	1
	5CB070-3	3
	5CB070-2	2
	5CB070-4	4

4. Use a **flathead screwdriver** to loosen the two screws from the end anchors that secure the auxiliary breakers to the DIN rail.



ATTENTION: Use caution when removing auxiliary breakers from DIN rail. Failure to use caution could result in personal injury or equipment damage.

- Use a **flathead screwdriver** to dislodge the circuit breaker from the DIN rail.

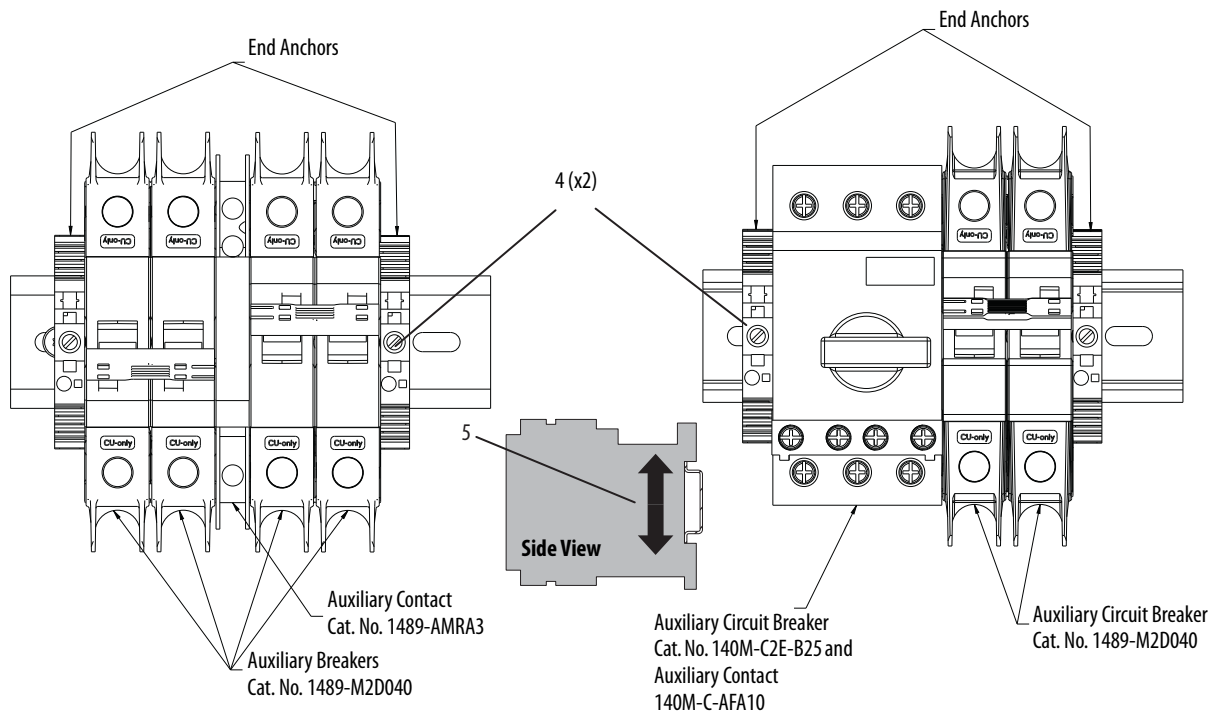

- Unpack and inspect the new circuit breaker.
- Attach the circuit breaker to the DIN rail.
- Use a **flathead screwdriver** to attach the wires from [step 3](#) to the terminals.
Torque screws to **12 lb•in.**
- Set the end anchors in place and use a **flathead screwdriver** to tighten their screws.
Torque screws to **4.4 lb•in.**
- Follow instructions to [Attach the Front Cover on page 169.](#)

Replace the Drive HIM (1HIM320)

Follow the procedure to [Remove Power on page 147](#) and follow the instructions to [Remove the Front Cover on page 148](#). For information on how to replace the HIM, see PowerFlex 20-HIM-A6 and 20-HIM-C6S HIM (Human Interface Module) User Manual, publication [20HIM-UM001](#) to install the 20-HIM-CS6 HIM. After the HIM is replaced, follow the instructions to [Attach the Front Cover on page 169.](#) and to [Apply Power on page 170.](#)

Replace the EMC Kit (1CH030)

Follow the procedure to [Remove Power on page 147](#) and follow the instructions to [Remove the Front Cover on page 148](#). For information on how to repair or replace the EMC kit (cat. no. 20-750-EMC1-F2) that is part of the drive, see PowerFlex 750-Series EMC Plate and Cores - Frames 1...7, publication [750-IN006](#). After the EMC kit is replaced, follow the instructions to [Attach the Front Cover on page 169](#). and to [Apply Power on page 170](#).

Replace the ETAP Module (6ET210)

1. Follow the procedure to [Remove Power on page 147](#)
2. Follow the instructions to [Remove the Front Cover on page 148](#).
3. Use a **flathead screwdriver** to disconnect the wires listed in the following table.

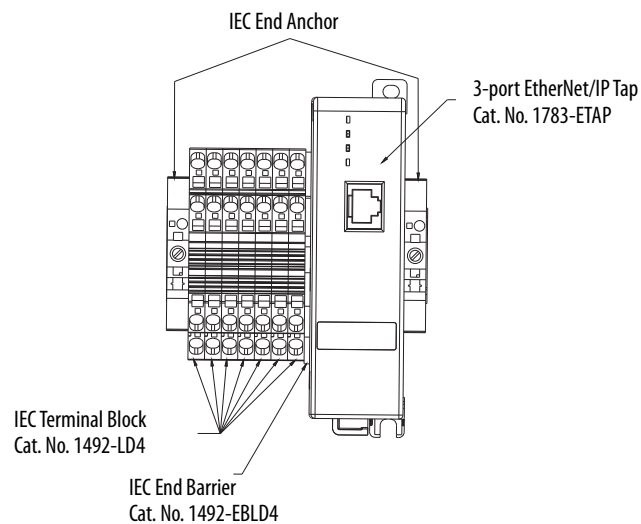

Wire Description	Terminal Number
6ET210 -0V	-
6ET210 +24V	+
ETH1	1 (front)
ETH2	2 (rear)
ENET_DRIVE	Device port on front panel

4. Disconnect the Ethernet cables.
5. Follow instructions in Ethernet Tap, publication [1783-PC011](#) to install the new ETAP module.
6. Use a flathead screwdriver to attach the wires from [step 3](#) to the terminals.
7. Follow the instructions to [Attach the Front Cover on page 169](#).

For information on how to configure the ETAP (cat. no. 1783-ETAP), see EtherNet/IP Network Configuration, publication [ENET-UM001](#).

Replace Receptacles on the Gland Plate

There are six installation methods available for the gland plate receptacles. Each method is based on the receptacle type.

IMPORTANT Many of the receptacles could appear to be interchangeable because they have the same mounting hole pattern. Verify your pin out and connectors before attaching to the On-Machine Drive. Review the electrical schematics and receptacle abbreviations.

The receptacle groups that follow have similar mounting hole patterns but, they are not interchangeable

- Encoder CFBM and Power Receptacle CPBM for ≤ 14 amp
 - M23 Encoders: ENCO, HIPSC, SSIL, Denco, DENC1, and SSISC
 - Power Receptacles: L123, T123, DBR, and EMB1
 - Control Power Receptacles: CP, CPBR, and EMB2
 - Safety Receptacles: S0 and S1
 - Control Power Receptacle: P0, P1, and DBRT
-

For all receptacle types, these steps apply:

1. Follow the procedure to [Remove Power on page 147](#).
2. Follow the instructions to [Remove the Front Cover on page 148](#).
3. Disconnect incoming 400/480V AC power and the auxiliary 24V DC power.



ATTENTION: Risk of equipment damage or malfunction. Note the cable and wire routing inside of the drive prior to removing any receptacle. The cable and wire routing for the replacement receptacle must be the same as the original.

4. Disconnect the patchcords of all respective receptacles from the enclosure side of the connector.
5. Go to the specific instruction for your receptacle type, complete replacement, and return to these instructions.

6. Torque receptacle to the corresponding torque.

Terminal Designation	Description	Torque Value (lb-in)
L123	Input Power	60 ± 10%
T123	Output Power	60 ± 10%
DRB	Dynamic Brake	60 ± 10%
EMB1	400/480V AC Source Mechanical Brake	45 ± 10%
EMB2	24V DC Mechanical Brake	45 ± 10%
CP	24V DC Control Power	45 ± 10%
CPBR	24V DC Brake Power	45 ± 10%
DBRT	Brake Resistor Thermostat Temperature	45 ± 10%
S0	S0 Safety (S3)	45 ± 10%
S0	S0 Network Safety (S4)	45 ± 10%
S0	S0 Network Safety (S4 with brake)	45 ± 10%
S1	S1 Network Safety (S4)	45 ± 10%
P0	P0 Digital Input	45 ± 10%
P1	P1 Digital Input	45 ± 10%
CFBM	Allen-Bradley Servo Bulk Head Hiperface Encoder - Bulk head adapter	11 ± 10%
	Allen-Bradley Servo Bulk Head Hiperface Encoder - Mounting screws	25 ± 10%
CPBM	Allen-Bradley Servo Motor Power and Brake - Bulk head adapter	11 ± 10%
	Allen-Bradley Servo Motor Power and Brake - Mounting screws	25 ± 10%
ENCO	M23 Incremental Encoder	133 ± 10%
HIPSC	M23 Hiperface SC Encoder	133 ± 10%
SSIL	M23 SSI Linear Encoder	133 ± 10%
DENCO	M23 Dual Incremental Encoder - 0	133 ± 10%
DENC1	M23 Dual Incremental Encoder - 1	133 ± 10%
SSISC	M23 SSISC Rotary Encoder	133 ± 10%
ETH1	EtherNet/IP Link 1	20 ± 10%
ETH 2	EtherNet/IP Link 2	20 ± 10%

7. Attach all removed patchcords and cables.

See [Receptacle Connections on page 47](#) for information on connection order and pin out details. See the electrical schematics for additional wiring information.

8. Follow the instructions to [Attach the Front Cover on page 169](#).

Receptacle Replacement - Type 1

The table below describes the receptacles that fall under type 1. Type 1 receptacles are installed on the bottom side of the gland plate, and the lock nut is installed from inside the enclosure.

Receptacle Abbreviation	Receptacle Function
L123	Input Power
S0 and S1	Safety
DBRT	Brake Resistor Thermostat Temperature
P0 and P1	Digital Input
T123 (< 22 amp)	Output Power
DBR (< 22 amp)	Dynamic Brake

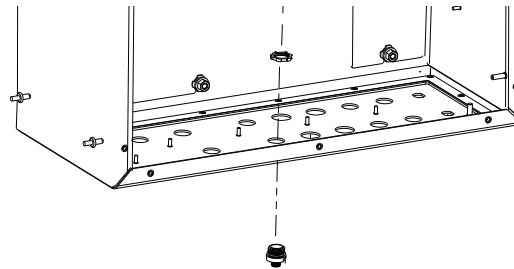

Receptacle Replacement - Type 2

The table below describes the receptacles that fall under type 2. Type 2 receptacles are installed with the receptacle and bulkhead adapter inside the enclosure. The sealing washer and screws are installed from the bottom side of the gland plate.

Receptacle Abbreviation ^{(1) (2)}	Receptacle Function
CPBM	Allen-Bradley Servo Motor Power and Brake
CFBM	Allen-Bradley Servo Bulk Head Hiperface Encoder

(1) CFBM and CPBM (for drive rating < 22 A) uses a type M4 screw.

(2) CPBM (for drive rating= 22 A) uses a type M5 screw.

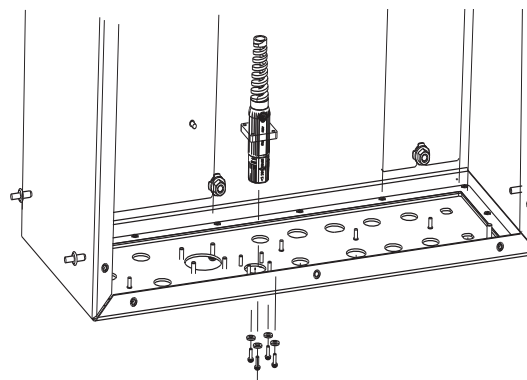

Receptacle Replacement - Type 3

The table below describes the receptacles that fall under type 3. Type 3 receptacles are installed from inside the enclosure, and the lock nut is installed from the bottom side of the gland plate.

Receptacle Abbreviation	Receptacle Function
HIPSC	M23 Hiperface SC Encoder
SSIL	M23 SSIL Linear Encoder
SSISC	M23 SSISC Rotary Encoder
ENCO	M23 Incremental Encoder
DENCO and DENC1	M23 Dual Incremental Encoder

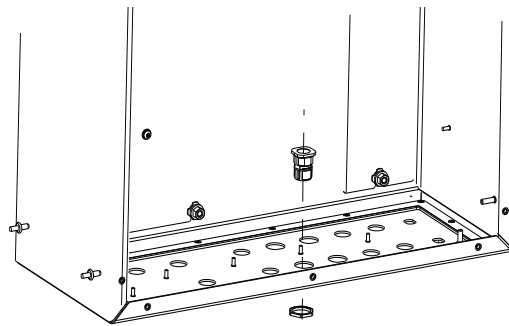

Receptacle Replacement - Type 4

The table below describes the receptacles that fall under type 4. Type 4 receptacles are installed from inside the enclosure, and the washer and lock nut are installed from the bottom side of the gland plate.

Receptacle Abbreviation	Receptacle Function
ETH1 and ETH2	EtherNet/IP Link

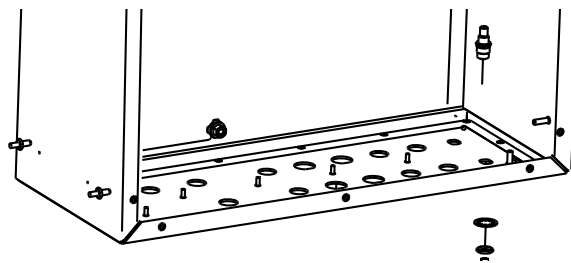

Receptacle Replacement - Type 5

The table below describes the receptacles that fall under type 5. Type 5 receptacles and o-ring are installed from the bottom side of the gland plate, and the lock nut is installed from inside the enclosure.

Receptacle Abbreviation	Receptacle Function
EMB1	400/480V AC Source Mechanical Brake
EMB2	24V DC Brake
CPBR	24V DC Brake Power
CP	24V DC Control Power

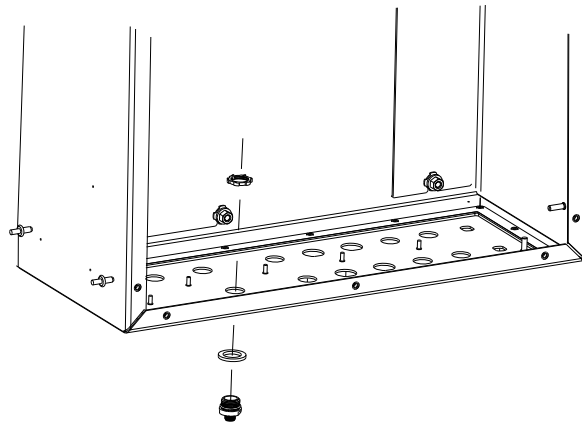

Receptacle Replacement - Type 6

The table below describes the receptacles that fall under type 6. Type 6 receptacles are installed from the bottom side of the gland plate, and the flat washer and lock nut are installed from inside the enclosure.

Receptacle Abbreviation	Receptacle Function
T123 (> 22 amp)	Output Power
DBR (> 22 amp)	Dynamic Brake

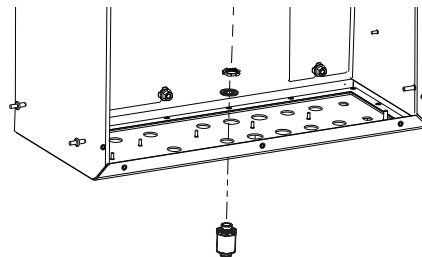

Attach the Front Cover

1. Verify that all terminals, connections, and wires are secure.
2. Verify that proper torque values were used.
3. Verify that the Ethernet cable is attached to the Frame 2 drive and the ETAP.
4. Attach the HIM cable to the Frame 2 receptacle.

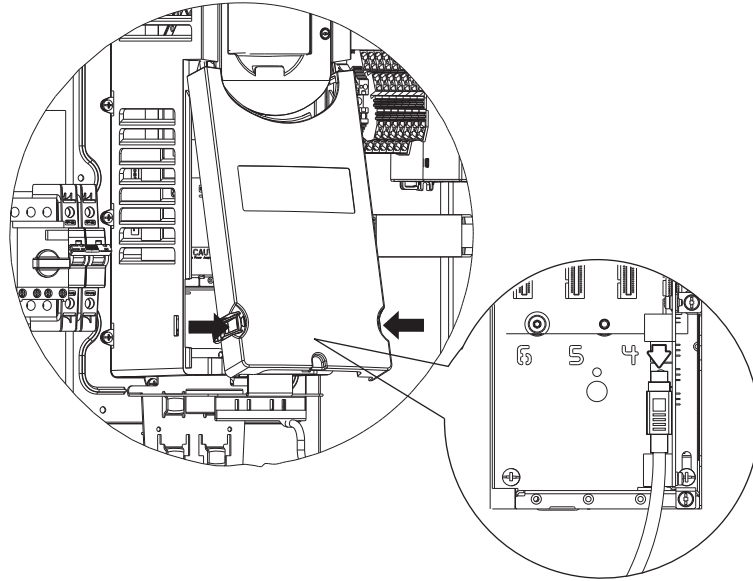

5. Attach the front covers to the Frame 2. See [Replace PowerFlex Frame 2 Drive \(1EA030\) on page 156](#) for more information on attaching the Frame 2 covers.
6. To align the drive cover, align the main circuit breaker shaft with the rotary disconnect switch, and allow them to fully mate.
7. Rotate the cover counter-clockwise to expose the grounding stud.
8. Use a 10 mm wrench to attach the nut and washer that secure the ground wire to the ground stud.
9. Verify that the HIM cable, ground wire, and Ethernet cable are properly stored.
10. Rotate cover clockwise to align the cover and enclosure holes.
11. Insert the 12 **M12 x 20 mm** screws and washers. Use the **T30 torque bit** to tighten the screws.
Torque the screws to **25 lb•in**
12. Reattach connector cables to the gland plate and torque them hand-tight.
13. Follow instructions to [Apply Power on page 170](#).

Apply Power

Application of power should only be performed by an experienced user after the drive is configured and has been through the start up procedure. Before applying power, it is recommended to review the precautions, warnings, and other advisory statements in [Prepare for Installation on page 17](#).

1. Attach all cables to their respective receptacles. See [Make Connections on page 44](#) and [Receptacle Connections on page 47](#) for more information.



ATTENTION: Do not cycle 400/480V AC power more frequently than one cycle every 1 minute - failure to comply will result in serious equipment damage.



ATTENTION: To avoid electrical shock, open the appropriate upstream protection (disconnect switch or branch circuit protection) before connecting and disconnecting cables. To avoid an electric shock hazard, verify that the voltage on the bus capacitors has entirely discharged before servicing.

IMPORTANT Many of the receptacles could appear to be interchangeable because they have the same mounting hole pattern. Verify your pin out and connectors before attaching to the drive. Review the electrical schematics and receptacle abbreviations.

The receptacle groups that follow have similar mounting hole patterns but, they are not interchangeable:

- Encoder CFBM and Power Receptacle CPBM for ≤ 14 amps
 - M23 Encoders: ENCO, HIPSC, SSIL, DENC0, DENC1, and SSISC
 - Power Receptacles: L123, T123, DBR, and EMB1
 - Control Power Receptacles: CP, CPBR, and EMB2
 - Safety Receptacles: S0 and S1
 - Control Receptacles: P0, P1, and DBRT
-

IMPORTANT The drive requires a solidly grounded delta-wye power source (for example, 480/277V AC or 400/230V AC, 3-phase power source). If applied to a grounded or ungrounded 400/480V AC delta power source, abnormal ground currents will be detected and cause the EMI filter to be damaged.

- Remove lock out / tag out from upstream power and apply power.

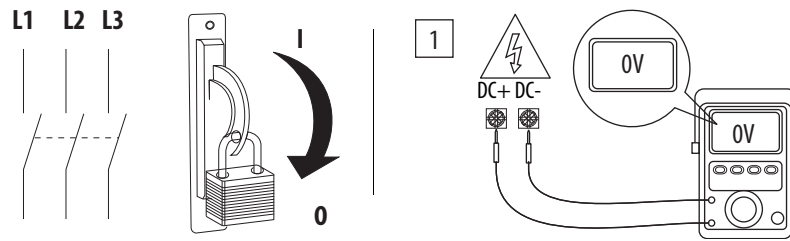

IMPORTANT The On-Machine Drive has multiple grounding locations. Refer to the electrical schematics for specific information about the grounding for your specific configuration. See the [Catalog Number Explanation on page 16](#) for more information about configuration type.

The safety ground, PE, must be connected to earth-grounding-system. Some codes may require redundant ground paths and periodic examination of connection integrity.

IMPORTANT This lock out / tag out is only for upstream power. During initial installation, the On-Machine Drive does not have power. The breakers should be in the OFF position when the unit arrives. Verify that all breakers are OFF before start up is initiated. For more information, see [Circuit Breakers on page 24](#) section.

- Turn on 24V DC control power circuit breaker (#3 in [Figure 10 on page 172](#)).
- Verify that the HIM energizes.
- Turn on the mechanical brake circuit breaker (#2 in [Figure 10 on page 172](#)).

Both circuit breaker options are shown, if a source brake option is used the breaker will have a rotary disconnect.

- Use the HIM or PLC to verify that the brakes have properly energized.

View **07:01 [Dig In Sts]** for verification. If bit 1 is equal to '1' all breakers are closed/energized. If bit 1 equals '0' then one of the three breakers is open/tripped.

TIP **07:01 [Dig In Sts]** should always be assigned and used as one of the Datalinks (to the PAC Network) for remote monitoring of the brake contactor status (Bit 0), circuit breaker status (Bit 1), and the P0 & P1 status (bits 2,3,4,5).

- Turn on the 400/480V AC main control power (#1 in [Figure 10 on page 172](#)).

Figure 10 - Circuit Breaker Identification

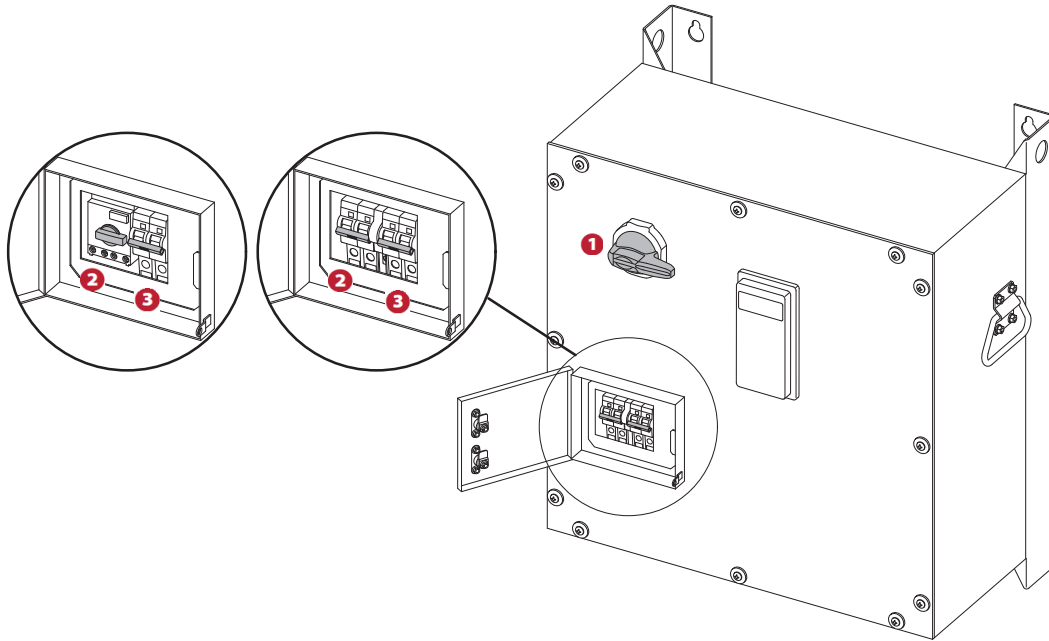

1. 400/480V AC rotary power for main circuit breaker (140G-G6C3-C30-AJ).
2. 24V DC mechanical brake circuit breaker (1489-M2D040) is shown on the enclosure.
The 400/480V AC source mechanical brake circuit breaker (140M-C2E-B25) is shown on the left.
3. 24V DC control power circuit breaker (1489-M2D2040).

8. Run the drive and test performance, if the Frame 2 drive was replaced, you must follow the start up procedure to recommission the drive.

Troubleshooting

Topic	Page
Electrical Safety Considerations	173
Fault Types, Descriptions, and Actions	174
Circuit Breaker Troubleshooting	176
Encoder Feedback Considerations	179
Troubleshooting Going Online	185

Electrical Safety Considerations

The drive is meant to be disconnected and repaired after proper lock out / tag out procedures have been employed.



ATTENTION: To avoid electrical shock, open the appropriate upstream protection (disconnect switch or branch circuit protection) before connecting and disconnecting cables. To avoid an electric shock hazard, verify that the voltage on the bus has entirely discharged before servicing.

IMPORTANT For drives that were in storage and did not have voltage applied, maintenance of the drive may be required. For drives that are stored under 2 years, there is no additional maintenance required. For storage greater than 2 years, see Preventive Maintenance Checklist of Industrial Control and Drive System Equipment, publication [DRIVES-TD001](#) for bus capacitor reforming requirements and [Maintenance of Industrial Control Equipment on page 197](#) for more information.



ATTENTION: The drive contains high voltage that takes time to discharge after removal of the main power supply. Before working on the drive, isolate the main power supply from line inputs (L1, L2, L3). Wait 3 minutes for the discharge to reach minimal voltage levels. Failure to do so may result in personal injury or death.

IMPORTANT To do proper troubleshooting, you need to have the electrical schematics available for your system.

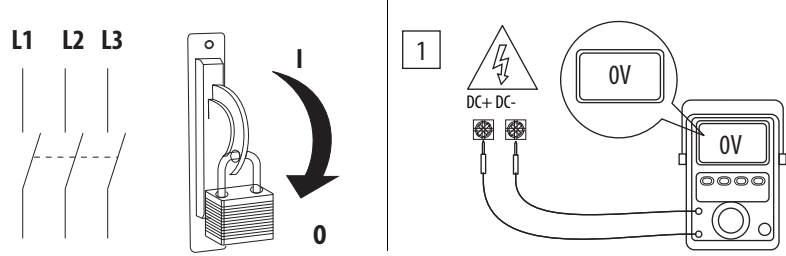

IMPORTANT This lock out / tag out is only for upstream power. During initial installation, the drive does not have power. The breakers should be in the OFF position when the unit arrives. Verify that all breakers are off before maintenance is started. For more information, see the [Circuit Breakers on page 24](#) section.



ATTENTION: This unit has remote sources of power. Disconnect all power sources before the cover is removed. Failure to comply could result in death or serious injury.

ATTENTION: Do not attempt to service internal components when the unit is energized. Complete lock out / tag out procedures for all input power sources. Then, remove input power to receptacle L123 and 24V DC control power to receptacles CP and CPBR (if used) before cover removal and inspection. Failure to comply can result in death or serious injury.

ATTENTION: The 24V DC control power source can be used to aid in troubleshooting, but you must follow local codes while the control power is energized, input power L123 is not energized, and the cover is removed. Control power is connected to receptacles CP (24V DC auxiliary power) and CPBR (24V DC brake options: B2 and B3). Failure to comply can result in serious injury or death.

Fault Types, Descriptions, and Actions

This section contains a table of faults and conditions that could occur and provides guidance on how to resolve them.

Issue	Description / Possible Cause	Action
PowerFlex 755® Alarms and Faults: motor/system does not run.	Alarms and Faults are annunciated on the HIM and the drive status is transmitted to the PLC via EtherNet/IP.	<p>See the HIM manual found in the Additional Resources on page 8 for details on using the 20-HIM-C6S to view Faults and alarm details.</p> <p>See the programming manual found in the Additional Resources on page 8 for details on PowerFlex 755 faults and alarms.⁽¹⁾</p>
Brake Contactor Status: no mechanical brake voltage at motor brake coil.	See the electrical schematics for details on the brake contactor coil wiring. Depending on which option is used, 24V DC is provided from Receptacle CP pins 1 and 4 or from the S4 safety option module safety output 0. In either case, 24V DC must be provided to terminals R0C and TC to be able to sequence the brake contactor.	<p>Use the HIM, Connected Components Workbench™ (CCW), DriveExecutive™, or Studio 5000™ Logix Designer to monitor the status of the brake contactor. The brake contactor auxiliary is wired to Digital Input 0.</p> <ul style="list-style-type: none"> Go to 07:01 [Dig In Sts] bit 0 to provide confirmation of the brake contactor status. 0 = open/set, 1 = closed/released. Monitor this parameter to see if it opens and closes as desired for the application. If it doesn't function as desired, check 07:10 [Relay Out 0] and 07:20 [Transistor Output 0] to see how they are configured. <p>These two outputs are wired in parallel to control the brake contactor coil. 07:06 [Digital Out Invert] can be used to change the state of the output to the brake contactor coil when controlled by Logix in I/O mode (but not in Integrated Motion mode).</p>
Safety Input: drive does not run.	See the electrical schematics for details on the Safety I/O option module wiring.	<p>Use the HIM, CCW, DriveExecutive, or Studio 5000 Logix Designer application to monitor the status of the safety option module by reviewing 00:933 [Start Inhibit].</p> <ul style="list-style-type: none"> All bits must be 0 for the drive to be able to run or jog. The safety option module controls the drive enable and safety options. Their status is available in bits 2 and 7. If both bits are 0 the safety inputs are made and the drive is able to run or jog. If the bit equals 1, the safety option module outputs are disabled and will not allow the drive to Run or jog. <p>See the appropriate safety manual found in Additional Resources on page 8 for specific details on the option module being used for enabling and disabling the drives safety circuits.</p>
Encoder Feedback	See the electrical schematics for details on the encoder feedback wiring options.	<p>Encoder Alarms and Faults are annunciated on the HIM. The drive status is transmitted to the PLC via EtherNet/IP.</p> <p>See the HIM manual found in the Additional Resources on page 8 for details on using the 20-HIM-C6S to view Faults and alarm details.</p> <p>See the programming manual found in the Additional Resources on page 8 for details on PowerFlex 755 faults and alarms.⁽¹⁾</p>
Circuit Breaker	<p>A visual inspection can verify that the breakers are individually opened or closed, or that the connections are loose.</p> <p>The 400/480V AC incoming power is provided to the main rotary circuit breaker through the receptacle L123.</p> <p>The mechanical brake circuit breaker (source brake circuit breaker or 24V DC brake circuit breaker) and the control power circuit breaker are located under the auxiliary circuit breaker door.</p> <p>Mechanical brake power is provided by the receptacle L123 for source brake or receptacle CPBR for the 24V DC brake. Control power is provided by the receptacle CP.</p>	<p>All three circuit breakers must be made with power present for the drive to operate and control a motor and the brakes properly.</p> <p>Main input circuit breaker and the brake circuit breaker have normally open (N.O.) contacts wired in series to digital input '1' on the digital I/O module mounted in slot 7. See the electrical schematics for details.</p> <p>When the 24V DC auxiliary control power is supplied to the unit Receptacle 'CP', you can check the status of the breakers using the HIM and by monitoring 07:01 [Dig In Sts] bit 1. If it is equal to '1' all breakers are closed/energized. If it is '0' then one of the three breakers is open/tripped.</p> <p>For additional information on circuit breaker troubleshooting, see Circuit Breaker Troubleshooting on page 176.</p>

(1) The PowerFlex 755 On-Machine™ Drive uses a PowerFlex Frame 2 drive. Any specific references to frame sizes other than Frame 2 in Chapter 6 of the programming manual should be ignored.

Circuit Breaker Troubleshooting

The drive has three circuit breakers that are accessible on the front cover. All three circuit breakers must have power present for the drive to operate and control a motor and its brake properly.

Open Auxiliary Circuit Breaker Door

1. Follow procedure to [Remove Power on page 147](#).
2. Use a (**flathead screwdriver**) to rotate the locks counter-clockwise to open the auxiliary circuit breaker door on the front cover.

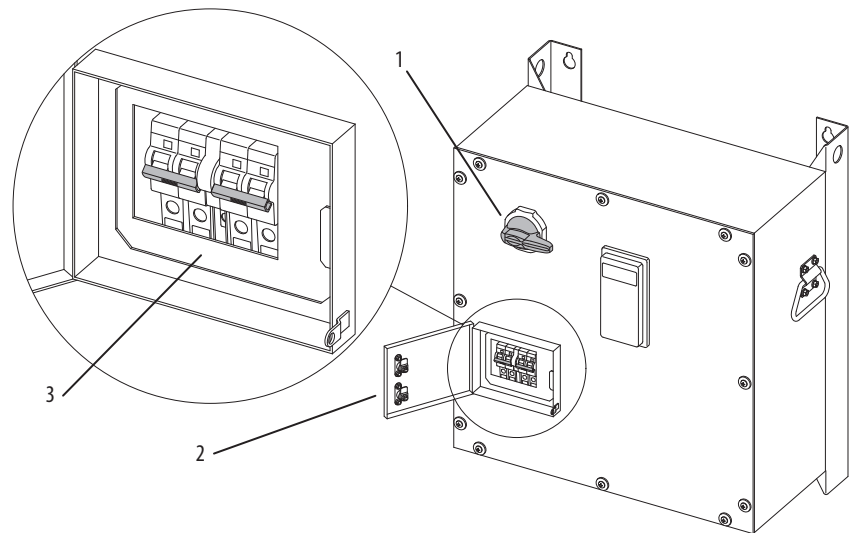

3. Switch all circuit breakers (main power 400/480V AC, 24V DC control power, and mechanical brake or source brake) to the OFF positions.



ATTENTION: To avoid an electric shock hazard, verify that the voltage on the bus has entirely discharged before servicing.

ATTENTION: The drive contains high-voltage that takes time to discharge after removal of the main power supply. Before working on the drive, isolate the main power supply from the line input (L123). Wait 3 minutes for the discharge to reach minimal voltage levels. Failure to do so can result in personal injury or death.



WARNING: Circumstances that can cause an explosion may exist, which may lead to personal injury or death, property damage, or economic loss. If the branch circuit protection device trips, you must use the software to verify that the source brake function is still operational before putting the equipment back in service. If the source brake function is not working properly, loss of brake function or motor damage can occur.

Reset Drive via the Circuit Breaker Switch

The main 400/480V AC input rotary circuit breaker is provided power via the M35 power receptacle (L123). The mechanical brake circuit breaker and the control power circuit breaker are located under the auxiliary circuit breaker door and are provided power by receptacles CP (24V DC auxiliary power) and CPBR (24V DC brake options B2 and B3), or L123 (source brake option SB). A visual inspection can verify that the breakers are individually open or closed.

Figure 11 - Circuit Breaker Definition Diagram

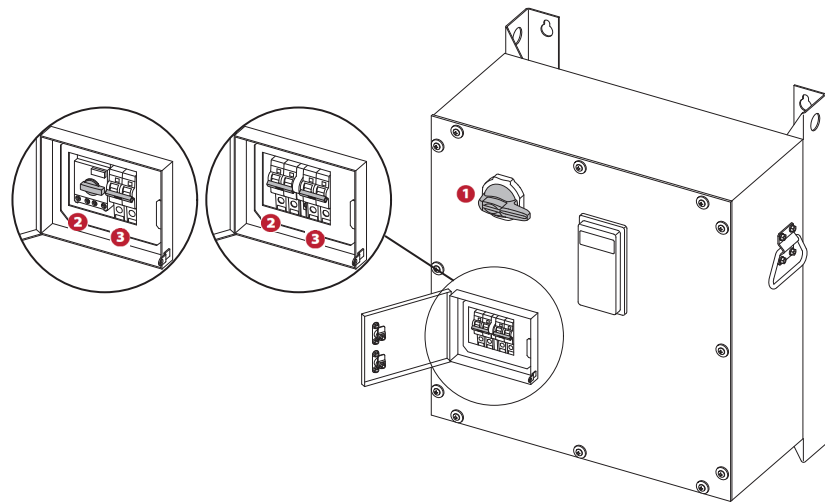

1. 400/480V AC rotary power for main circuit breaker (140G-G6C3-C30-AJ).
2. 24V DC mechanical brake circuit breaker (1489-M2D040) is shown on the enclosure.
The 400/480V AC source mechanical brake circuit breaker (140M-C2E-B25) is shown on the left.
3. 24V DC control power circuit breaker (1489-M2D2040).

In addition to visual inspection, two of these breakers (24V DC control power circuit breaker and the mechanical brake circuit breaker) have normally open (N.O.) contacts. The N.O. contacts are wired in series to digital input 1 on the digital I/O module mounted in slot 7.

When the 24V DC auxiliary control power is supplied to the unit (receptacle CP), you can check the status of the breakers by monitoring **07:01 [Dig In Sts] bit 1**, via the cover-mounted HIM or via EtherNet/IP. If it is equal to 1 all breakers are closed/energized. If it is 0, then one or more of the three breakers is open/tripped.

To help determine which of the three breakers are open (or tripped), check the following in order:

1. Visually inspect the three breakers to verify if one of them is open.
 - If yes, reset it and energize it.
 - If no, something else is wrong.

2. Turn off the Main 400/480V AC input circuit breaker.



ATTENTION: Do not cycle 400/480V AC power more frequently than one cycle every 1 minute - failure to comply will result in serious equipment damage.

3. With the main breaker open, determine if the cover-mounted HIM is energized.
 - If yes, then the 24V DC control power (CP) is present. Control Power must be present to monitor the Input I/O status.
 - If no, then energize the 24V DC control power. See [Figure 11 on page 177](#) for more details.
4. Turn the Main circuit breaker on before proceeding to [step 5](#). See [Apply Power on page 170](#) and follow the instructions to energize the system.
5. Check **00:11 [DC Bus volts]**:
 - If it is between 515...670V AC then the main incoming (400/480V AC) is present through the L123 receptacle and the main input circuit breaker is closed.
 - If it is not between 515...670V AC, then either the main input rotary breaker is open or there is no power present on the L123 receptacle.
 - If there is no power present at the L123 receptacle, go to the customer Power Distribution Panel (PDP) and verify the power source to the M35 trunk line is energized (400/480V AC).
6. If 24V DC (CP) control power circuit breaker from [step 1](#) is energized and the main input power is present, then the only breaker that can be open is the brake circuit breaker. Reset the breaker and recheck **07:01 [Dig In Sts]** bit 1 to confirm that all three breakers are now closed.

Notes:

- You must use a tool to open the auxiliary circuit breaker door on the front cover to inspect the mechanical brake and 24V DC control circuit breakers.
- There are two types of brake circuit breakers:
 - (1) 24V DC breaker for brake Option B2 or B3 (CPBR).
 - (2) 400/480V AC breaker for brake option SB (L123).
- **07:01 [Dig In Sts]** should always be assigned and used as one of the Datalinks (to the PAC Network) for remote monitoring of the brake contactor status (Bit 0), CB status (Bit 1), and the P0 & P1 status (Bits 2, 3, 4, 5).

Encoder Feedback Considerations

This section provides additional information about the encoders, their common issues, and system components.

Refer to the PowerFlex 750-Series AC Drives Programming Manual, publication [750-PM001](#) for encoder faults and corrective actions. If after reviewing the information in the programming manual, the front cover needs to be removed, see [Remove the Front Cover on page 148](#) to perform a visual inspection.



ATTENTION: If a visual inspection is required, follow the instructions to [Remove Power on page 147](#) and [Remove the Front Cover on page 148](#). Failure to do so could result in personal injury, death, or machine damage.

Potential Encoder Feedback Issues

This is a list of possible items that could be observed. This list is not all inclusive and will vary based on the design of your mechanical system. Refer to the PowerFlex 750-Series AC Drives Programming Manual, publication [750-PM001](#) for encoder faults and corrective actions.

- Encoder faults (refer to manual for details)
- Noise – check wiring, grounding, shielding and field routing
 - Keep high power and low power separated
- Encoder feedback device insertion
- Encoder cable pin-out and terminations
- Encoder configuration in drive (PPR, voltage, and so on.)
- Coupling and setscrews to motor stub shaft
- Motor grounding and shielding
- Load side SSI Encoder alignment
- Load side encoder configuration in drive

- Load side encoder cable and pin outs

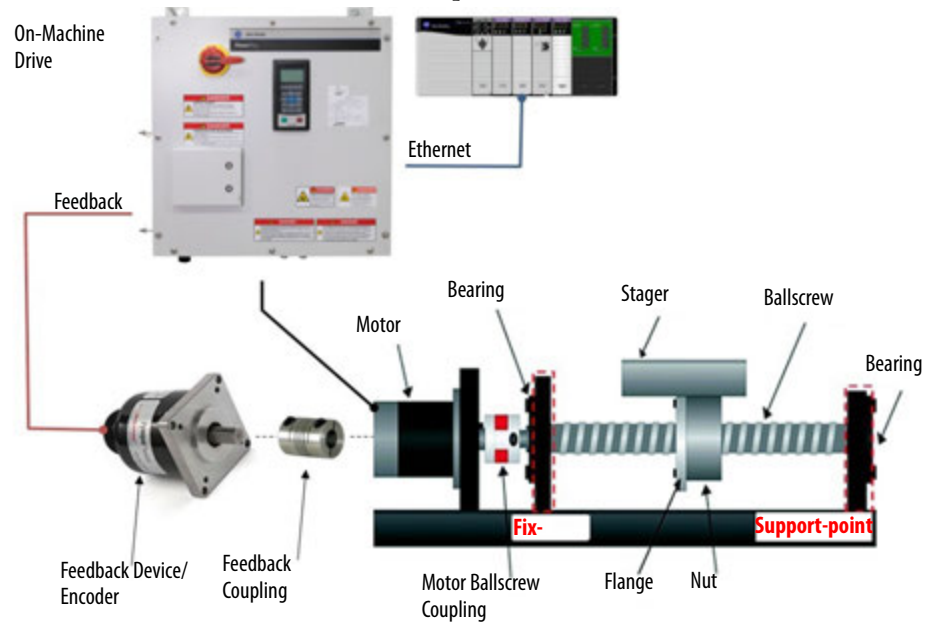

Encoder System Components

This is a list of possible items that could be observed. This list is not all inclusive and will vary based on the design of your mechanical system. Refer to the PowerFlex 750-Series AC Drives Programming Manual, publication [750-PM001](#) for encoder faults and corrective actions.

- Main control module
- Option Module backplane connector
- Encoder feedback device (slots 4 and 5)
- Encoder cables and pin outs
- Encoder (Incremental, Absolute)
- Coupling and setscrews to motor stub shaft
- Motor, grounds, and shields
- Load side SSI Encoder

- Load side encoder cables and pin outs



ATTENTION: If a visual inspection is required, follow the instructions to [Remove Power on page 147](#) and [Remove the Front Cover on page 148](#). Failure to do so could result in personal injury, death, or machine damage.

Mechanical Checks

This is a list of possible items that could be observed. This list is not all inclusive and will vary based on the design of your mechanical system. Refer to the PowerFlex 750-Series AC Drives Programming Manual, publication [750-PM001](#) for encoder faults and corrective actions.

- Loose coupling
 - Missed positioning
 - Erratic motion
 - Hardwire over-current faults
- Broken coupling
 - Speed/position errors
- Mechanical bind
 - than normal current (amps) to move slide
 - Motor hotter than normal and possible over temperature
 - Feedback position error faults

Positioning Troubleshooting Flowcharts

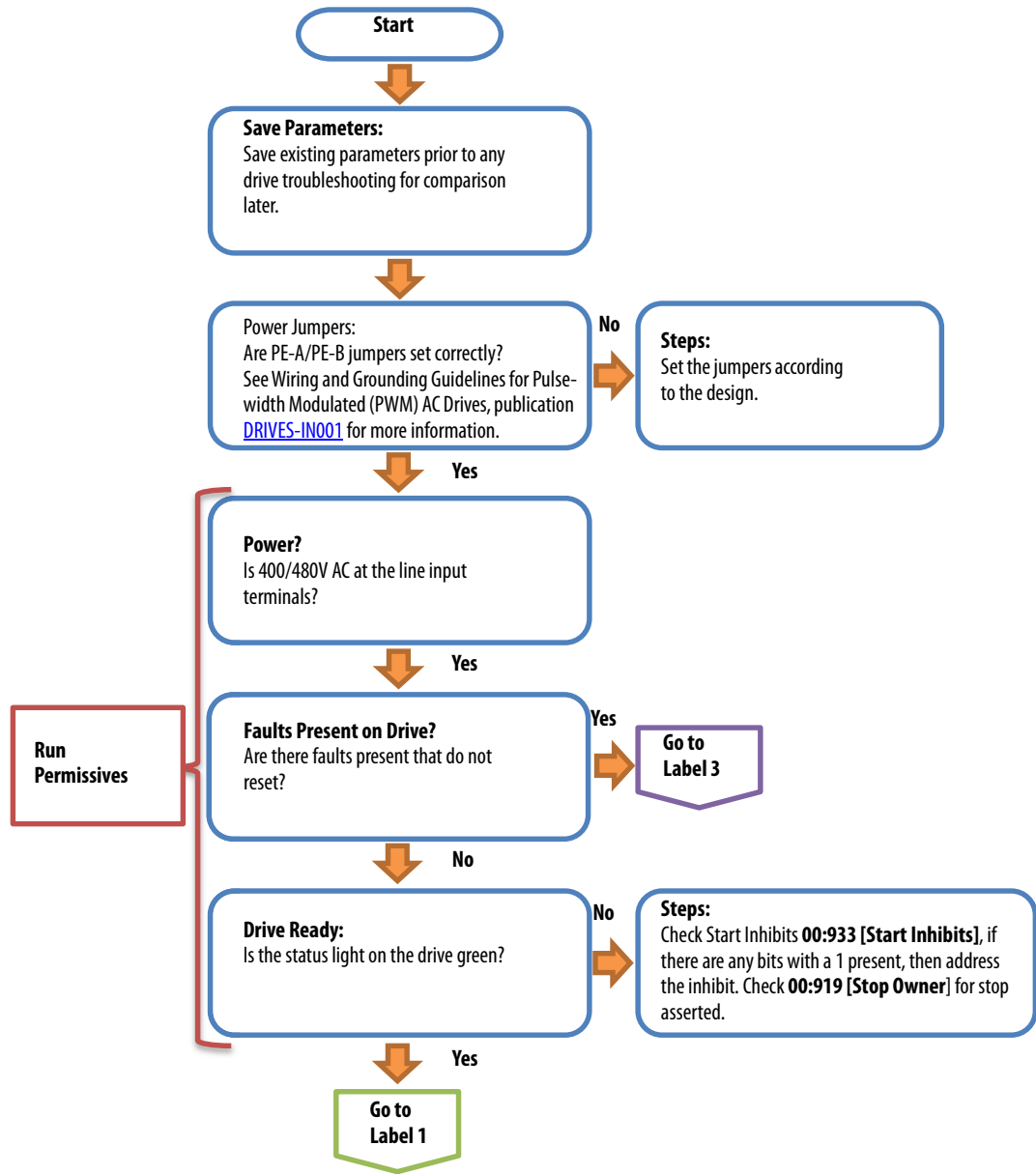

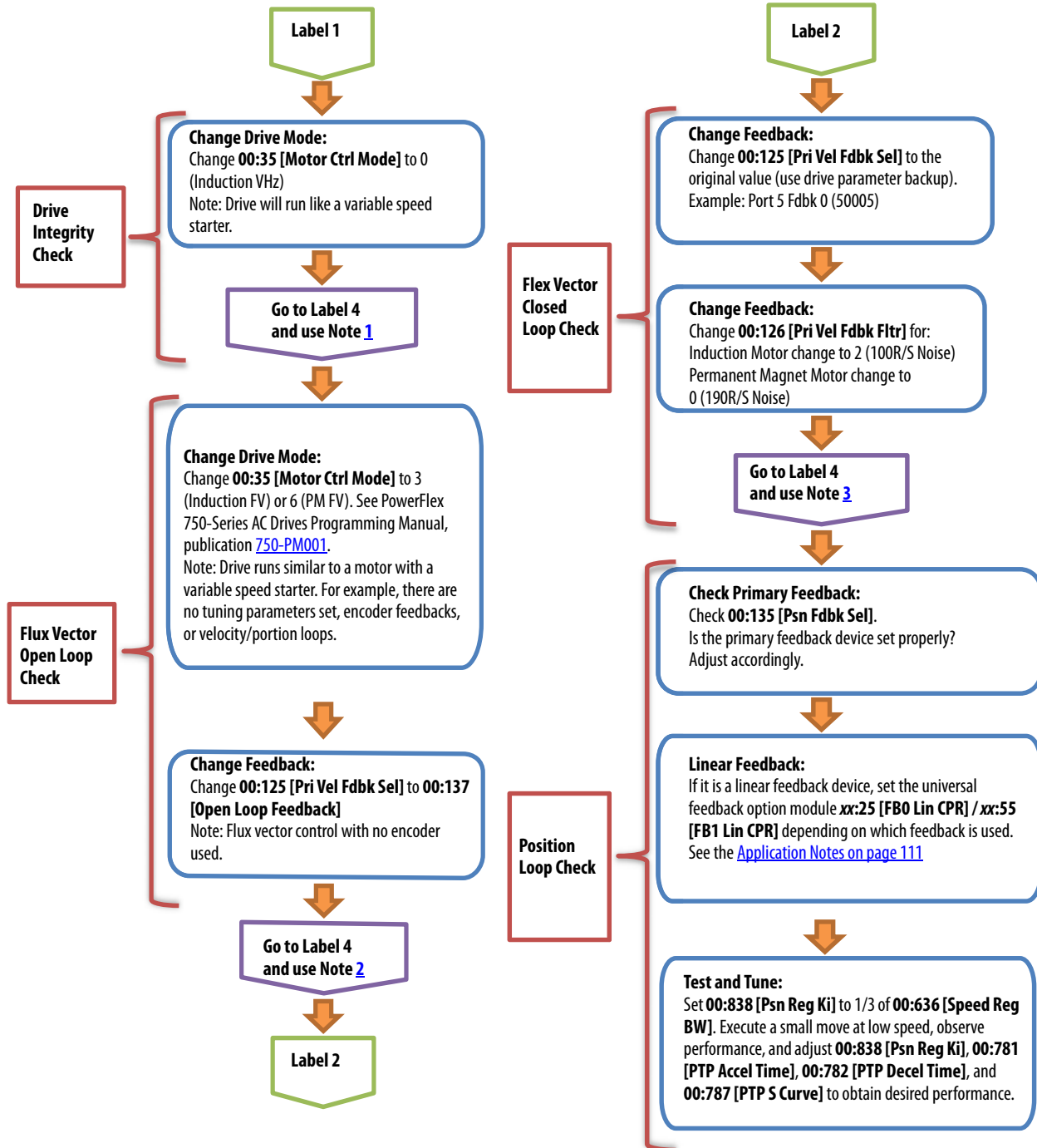

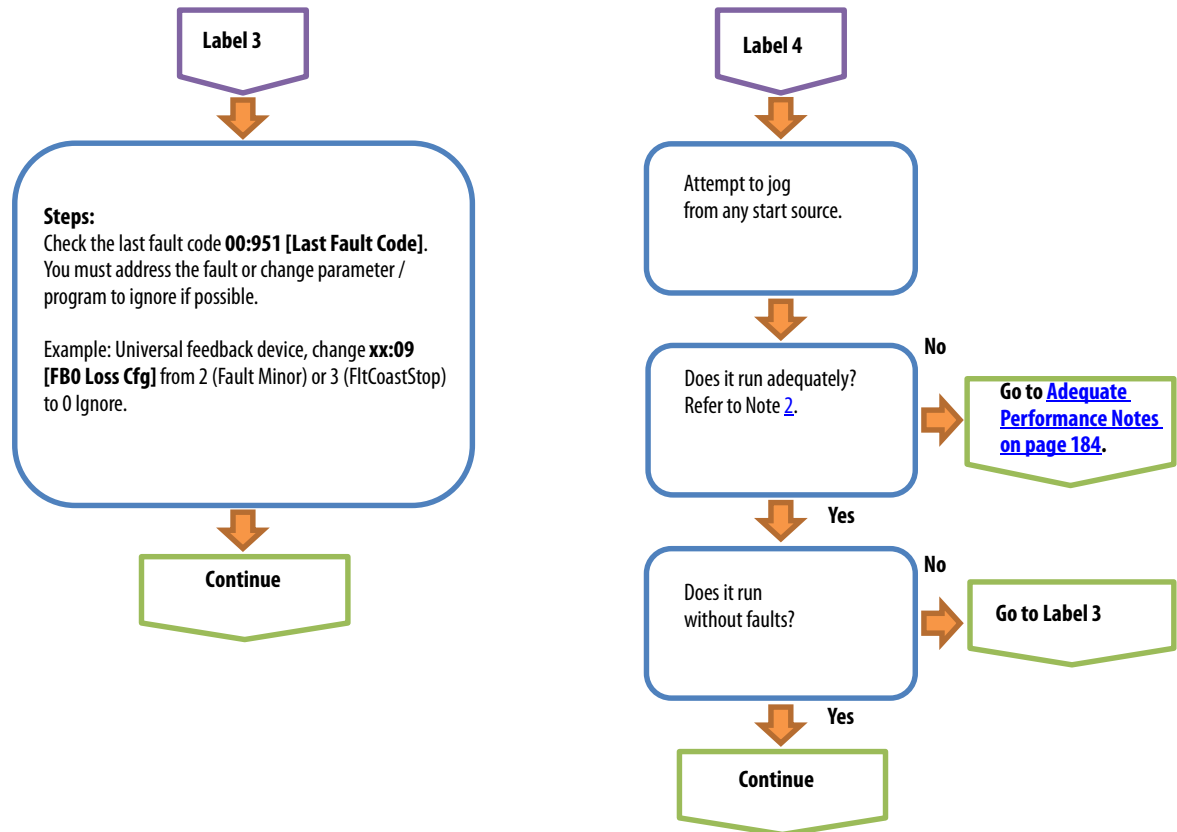

Adequate Performance Notes

1. Drive Integrity Check
 - a. Is the Motor spinning?
 - b. Is the mechanical brake releasing?
 - c. Is the motor wired correctly?
 - Use a megger meter to confirm wiring. Disconnect motor from the drive and use a megger meter to test the motor and check the electrical continuity within the motor, this is a special type of ohmmeter used to measure the electrical resistance of insulators.
2. Flux Vector Open Loop Check should yield a speed regulation of +/- rpm of set point. If not, determine whether the drive startup procedure was followed: 00:25 [Motor NP Volts], 00:31 [Motor Poles], 00:75 [Flux Current Ref], 00:76 [Total Inertia].
 - a. If 00:76 [Total Inertia] is too high, then the gains might be too high. 00:76 [Total Inertia] and 00:636 [Speed Reg BW] create 00:645 [Speed Reg Kp] / 00:647 [Speed Reg Ki] of the speed loop. Values that are too high create instability. Look at 00:690 [Limited Tqr Ref] and 00:945 [At Limit Status] for instability.
 - b. Check ratio of 00:75 [Flux Current Ref] / 00:26 [Motor NP Amps] (Flux/Motor nameplate current)

- Use this link to refer to Knowledgebase articles <https://www.rockwellautomation.com/rockwellsoftware/support/knowledgebase.page>
 - If ratios exceeds 50% then use a calculated value.
3. Flux Vector Closed Loop Check should yield a speed regulation of +/- 1 rpm of set point. If not, check the following:
 - a. The encoder shield / cable routing
 - b. The encoder mounting integrity
 - c. The connections at the encoder and the encoder feedback device
 - d. **00:636 [Speed Reg BW]**, adjust to achieve +/- 1 RPM of setpoint.

Troubleshooting Going Online

This section captures various scenarios that could help resolve issues in going online with the drive.

View Adapter Status By Using Parameters

The following parameters provide information about the status of the adapter. You can view these parameters through **Port 13** at any time.

Adapter Parameter	Description
34 [DLs From Net Act]	The number of controller-to-drive datalinks that are included in the network I/O connection (controller outputs).
35 [DLs To Net Act]	The number of drive-to-controller datalinks that are included in the network I/O connection (controller inputs).
36 [BOOTP]	Displays the source from which the adapter IP address is taken. The source can be either of the following: The IP address switch settings or Parameter 36 [BOOTP] 0= Parameters—uses the address from Parameters 38...41 [IP Addr Cfg x] 1=BOOTP—the default
51 [Net Rate Act]	The data rate used by the adapter.
86 [Fr Peer Status]	The status of the consumed peer I/O input connection, which can be one of the following values: 0 = Off 1 = Waiting 2 = Running 3 = Faulted
77 [DLs Fr Peer Act]	The number of peer-to-drive datalinks that the drive is expecting.
88 [DLs To Peer Act]	The number of drive-to-peer datalinks that the drive is expecting.

Access the Adapter Web Pages

To access the internal web browser, open your computers internet browser and enter the IP address of the desired drive (for example, 192.168.1.1). From here,

you are able to view parameter settings, device status, and diagnostics from multiple tab views.

IMPORTANT When editing a parameter the default User Name is Administrator and there is no password. The user should set the password to a unique value for authorized personnel.

By using a web browser to access the IP address set for the adapter, you can view the adapter web pages for information about the adapter. You can also view information about the drive, and other DPI™ devices connected to the drive, such as HIMs or converters.

By default, the adapter web pages are disabled. To enable the adapter web pages, set **13:52 [Web Enable]** to 1 (Enabled) and then reset the adapter for the change to take effect.



Value	Description
0	Disabled (Default)
1	Enabled

For more details on the web pages for the adapter, see PowerFlex 755 Drive Embedded EtherNet/IP Adapter User Manual, publication [750COM-UM001](#).

The adapter can be configured to send email messages automatically to desired addresses when:

- Selected drive faults occur and/or are cleared
- The adapter takes a communication or idle fault action

Bit 0 of **13:53 [Web Features]** is used to help protect the configured settings for email messaging. By default, settings are not protected and changes can be made.

- To help protect configured settings, set the value of Email Cfg Bit 0 to 0 (Disabled).
- To remove protection from the configuration, change Bit 0 back to 1 (Enabled).

Email messaging always remains active regardless of whether its settings are protected—unless email messaging was **never** configured. For more information about the configuration of adapter email messaging or to stop email messages, see PowerFlex 755 Drive Embedded EtherNet/IP Adapter

User Manual, publication [750COM-UM001](#), Configure Email Notification Web Page.



Bit	Description
0	Email Cfg (Default = 1 = Enabled)
1...15	Not Used

Bit 0 is the right-most bit. In the example above, it equals 1 (Enabled).

TIP Changes to this parameter take effect immediately. A reset is not required.

Resetting the Adapter

Changes to switch settings and some adapter parameters require that you reset the adapter before the new settings take effect. You can reset the adapter by cycling power to the drive or by using the Reset Device function of the HIM in the DIAGNOSTIC folder for the drive.



ATTENTION: Risk of injury or equipment damage exists. If the adapter is transmitting control I/O to the drive, the drive can fault when you reset the adapter. Determine how your drive responds before resetting the adapter.

Set a Fault Action

The drive responds by faulting if it is using I/O from the network. You can configure another response to these faults:

- Disrupted I/O communication by using **13:54 [Comm Flt Action]**
- An idle controller by using **13:55 [Idle Flt Action]**
- Disrupted peer I/O by using **13:56 [Peer Flt Action]**
- Disrupted MSG instruction for drive control via PCCC, the CIP Register Object, or the CIP Assembly Object by using **13:57 [Msg Flt Action]**.



ATTENTION: Risk of injury or equipment damage exists if communication is disrupted, the controller is idle, peer I/O is disrupted, or MSG instruction for drive control is disrupted. To determine the action of the adapter and drive, use the **Port 13** embedded adapter parameters:

- **54 [Comm Flt Action]**
- **55 [Idle Flt Action]**
- **56 [Peer Flt Action]**
- **57 [Msg Flt Action]**

By default, these parameters fault the drive. You can configure these parameters so that the drive continues to run, however verify that the settings of these parameters do not create a risk of injury or equipment damage. When commissioning the drive, verify that your system responds correctly.

Set the values of **13:54 [Comm Flt Action]**, **13:55 [Idle Flt Action]**, **13:56 [Peer Flt Action]**, and **13:57 [Msg Flt Action]** to an action that meets your application requirements.

Value	Action	Description
0	Fault	The drive faults and stops. (Default)
1	Stop	The drive stops but does not fault.
2	Zero Data	The adapter sends 0s to the drive.
3	Hold Last	The adapter continues to send the data present at the time of the action.
4	Send Flt Cfg	The adapter sends the logic command reference and data that is configured in these Port 13 parameters to the drive: (<i>Host Parameters: 58 [Flt Cfg Logic], 59 [Flt Cfg Ref], and 60 [Flt Cfg DL 01] ... 75 [Flt Cfg DL 16]</i>).

Figure 12 - Edit Fault Action HIM Screen Example

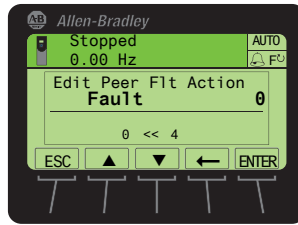

Changes to these parameters take effect immediately. A reset is not required.

If communication is disrupted and then re-established, the drive automatically receives commands over the network again.

Set the Send Fault Configuration Parameters

When any of these **Port 13** parameters are set to Send Flt Cfg the values in [Table 8](#) are sent to the drive:

- **54 [Comm Flt Action]**
- **55 [Idle Flt Action]**
- **56 [Peer Flt Action]**
- **57 [Msg Flt Action]**

TIP Only one fault can register at a time. If several faults occur, they are processed in the order in which the system receives them.

The values are sent after a communication fault, idle fault, peer I/O fault, and/or after a MSG instruction for drive control fault occurs. You must set these **Port 13** parameters to values required by your application.

Table 8 - Fault Configuration Parameter Values

Adapter Parameter	Description
58 [Flt Cfg Logic]	A 32 bit value sent to the drive for Logic Command.
59 [Flt Cfg Ref]	A 32 bit REAL (floating point) value that is sent to the drive for Reference.
60 [Flt Cfg DL 01] ... 75 [Flt Cfg DL 16]	A 32 bit integer value that is sent to the drive for a Datalink. If the destination of the Datalink is a REAL (floating point) parameter, you must convert the desired value to the binary representation of the REAL value. An internet search of hex to float provides a link to a tool to do this conversion.

Changes to these parameters take effect immediately. A reset is not required.

Restore Adapter Parameters to Default Configurations







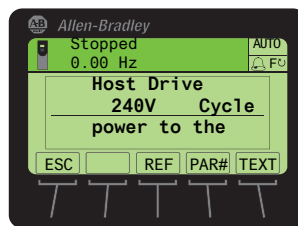

Adapter parameters can be restored in two ways:

- ALL—restores ALL adapter parameters to their default configuration values.
- MOST—restores MOST adapter parameters—except the following, **Port 13** parameters which are used for network setup:
 - 36 [BOOTP]
 - 38...41 [IP Addr Cfg 1...4]
 - 42...45 [Subnet Cfg 1...4]
 - 46...49 [Gateway Cfg 1...4]
 - 50 [Net Rate Cfg]

Follow these steps to restore adapter parameters to their default configuration values.

1. Access the Status screen, which is displayed on HIM power up.



2. Use the  or  key to scroll to **Port 13**, which is always the drive port that is dedicated to the embedded EtherNet/IP adapter.
3. Press the  key to display the last-viewed folder.
4. Use the  or  key to scroll to the MEMORY folder.
5. Use the  or  key to select Set Defaults.
6. Press the  (Enter) key.
The Set Defaults dialog box appears.
7. Press the  (Enter) key again.
The warning dialog box appears.

8. Reset parameters to their default configuration values by selecting the appropriate option:
 - To restore MOST *Device* and *Host* parameters to default configurations, press the MOST *soft key*.
 - To restore ALL parameters, press the ALL *soft key*.
 - To cancel, press the ESC *soft key*.

IMPORTANT When performing [Restore Adapter Parameters to Default Configurations on page 190](#), the drive can detect a conflict and then not allow this function to occur. If a conflict happens, first resolve the conflict and then repeat the [Restore Adapter Parameters to Default Configurations on page 190](#) procedure. The common reasons for a conflict include: a drive that is running or a controller in Run mode.

9. Reset the adapter by cycling power to the drive or by using the Reset Device function of the HIM, in the DIAGNOSTIC folder for the drive.



ATTENTION: Risk of injury or equipment damage exists. If the adapter is transmitting control I/O to the drive, the drive can fault when you reset the adapter. Determine how your drive responds before resetting the adapter.

Updating the Drive Firmware

The drive firmware is contained within the PowerFlex 755 drive firmware. To obtain a firmware update for the PowerFlex 755 drives, go to the Product Compatibility and Downloads Center (PCDC) <http://compatibility.rockwellautomation.com/Pages/home.aspx>. This website contains all firmware update files and associated Release Notes that describe the following items:

- Firmware update enhancements and anomalies
 - How to determine the existing firmware revision
 - How to update the firmware using ControlFLASH™, DriveExplorer™, DriveExecutive™, or HyperTerminal™ software.
1. In RSLinx Classic Gateway, select drive from project tree.

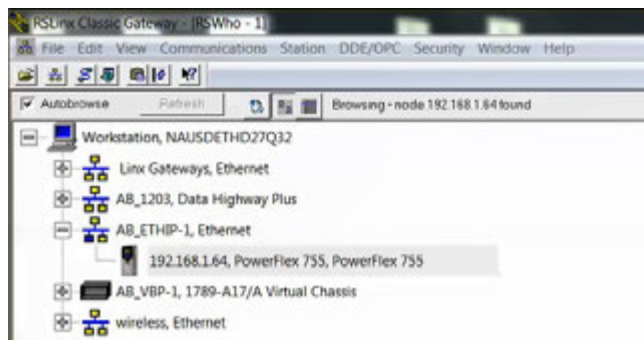

2. Right click on the drive, and select Device Properties.
Review current firmware version and read all Release Notes that apply between the current version and the upgrade version.
3. Verify that 24V DC auxiliary control power is ON.
4. Verify the EtherNet/IP is connected and transmitting.
5. Go to the PCDC and search for PowerFlex 755.



6. From the search generated list, select PowerFlex 755.
The available firmware versions appear.
7. Select the appropriate firmware version and click Downloads.



8. From the Downloads page, click Select Files.
9. Select the files to download.



- After you select the files to download, you are required to enter your registered email and password. Sign in and acceptance to the Software End-User License Agreement are required to obtain downloads.

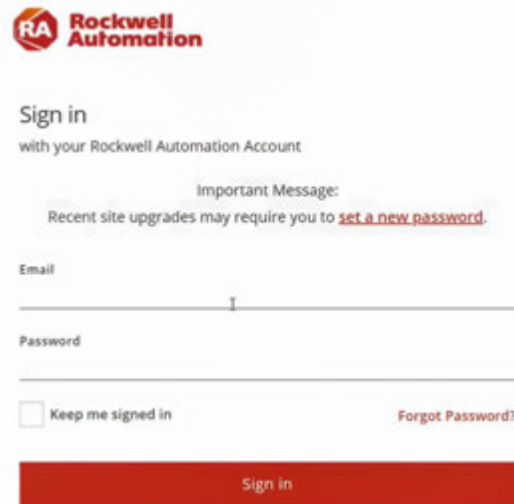

- Choose Managed Download or Direct Download. Follow the prompts to complete the download.
- Open ControlFLASH.
- Click Next.



- In the Catalog Number dialog box, select your drive from the list.
LP stands for low power, HP stands for high power.
- In the Select the PowerFlex 755... device to update dialog box, expand the project tree and select your drive.
- Click Ok.
- In the Firmware Revision dialog box, select "Show all revisions" and choose the version of software you want to install.
- Click Next.

19. Review the Summary dialog box and click Finish to update the firmware.
20. In the ControlFLASH dialog box, select Yes to confirm update.
The drive flashes and a status window indicates the progress. The drive reboots after the firmware download is complete.
21. After the connection to the drive is re-established, ControlFLASH indicates if the update was successful.

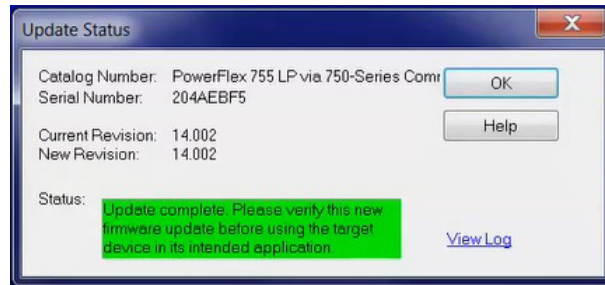

22. Click OK to exit.
23. Close the ControlFLASH software.

Periodic and Preventative Maintenance

Topic	Page
Recommended Preventive Maintenance	195
Maintenance of Industrial Control Equipment	197

This chapter provides information on how to perform preventive maintenance on the PowerFlex® 755 On-Machine™ Drive and components that can affect the life and operability of the drive.

Recommended Preventive Maintenance

Rockwell Automation recognizes that following a defined maintenance schedule delivers the maximum product availability. By strictly following the maintenance schedule that is provided, you can expect the highest possible uptime.

This annual preventive maintenance program includes the following primary tasks:

- A visual inspection of all drive components
- General cleaning and maintenance
- Tightness checks on all power connections
- Tightness checks on all bottom-plate connectors

See Chapter 5- [Drive Maintenance](#) and Chapter 6- [Troubleshooting](#) for additional information on how to inspect and test the system.

The recommended maintenance tasks and schedule for a drive are contained in [Maintenance of Industrial Control Equipment](#) on page [197](#). The Schedule Codes Explanations section on page [196](#) contains an explanation of the codes that are contained in the recommended maintenance tasks and schedule tables.

IMPORTANT Duty cycle, load profile, temperature, altitude, incoming line conditions, and other operating/environmental conditions greatly affect reliability of a drive.

Schedule Codes Explanations

The following codes are used to indicate the tasks that are associated with the components that are identified in the recommended tasks and maintenance schedule tables on pages [197...202](#).



ATTENTION: Servicing energized industrial control equipment can be hazardous. Severe injury or death can result from electrical shock, burn, or unintended actuation of controlled equipment.

Recommended practice is to disconnect and lock out / tag out control equipment from power sources, and discharge stored energy in the system, if present. If it is necessary to work in the vicinity of energized equipment, only qualified personnel are permitted to perform such work. Adhere to all applicable safety practices and wear protective equipment.

IMPORTANT Review product manuals for detailed maintenance information relevant for a particular model.

Code	Task	Description
I	Inspect	Inspect the component for signs of excessive accumulation of dust, dirt, or external damage. For example, inspect the drive heatsink fan inlet screen for debris that can block the airflow path.
C	Clean	Clean the components, specifically the drive heatsink fan inlet screen.
M	Maintain	This type of maintenance task can include tightening loose terminal and cable connectors.
R	Replace	This component has reached its mean operational life. Replace the component to decrease the chance of failure. It is likely that components can exceed the designed life in the drive, but component life is dependent on many factors such as usage, and heat.
RFB/R	Refurbish/Replace	The parts can be refurbished, at lower cost, or replaced with new ones.
Rv	Review	A discussion with Rockwell Automation® personnel is recommended to help determine whether any of the enhancements/changes made to the drive hardware and control could benefit the application.

Maintenance of Industrial Control Equipment



ATTENTION: Performing service on energized Industrial Control Equipment can be hazardous. Severe injury or death can result from electrical shock, bumping, or unintended actuation of controlled equipment. Recommended practice is to disconnect and lock out / tag out control equipment from power sources, and release stored energy, if present. See National Fire Protection Association Standard No. NFPA 70E, Part II (as applicable) OSHA rules for Control of Hazardous Energy Sources (lock out / tag out), and OSHA Electrical Safety Related Work Practices for safety-related work practices. These publications include procedural requirements for lock out / tag out, appropriate work practices, personnel qualifications, and training requirements where it is not feasible to de-energize and lock out / tag out electric circuits and equipment before working on or near exposed circuit parts.

Periodic Inspection — Industrial control equipment must be inspected periodically. Inspection intervals are based on environmental/operating conditions, and adjusted as indicated by experience. We recommend an initial inspection within 3...4 months after installation. We recommend an annual inspection after initial inspection, and on an ongoing basis.

Real-time Clock - Factory-installed CR1220 lithium coin cell battery provides power to the real-time clock (supplied). Preserves the clock setting in the event power to the drive is lost or cycled. Approximate life is 4.5 years with drive unpowered, or lifetime if drive is powered. For configuration and replacement information, refer to the PowerFlex 750-series AC Drives Reference Manual, publication [750-RM002](#).

Contamination — If inspection reveals that dust, dirt, moisture, or other contamination has reached the control equipment, the cause must be eliminated. This contamination can indicate an incorrect or ineffective enclosure, unsealed enclosure openings (conduit or other), or incorrect operating procedures. Dirty, wet, or contaminated parts must be replaced unless they can be cleaned effectively by vacuuming or wiping.



ATTENTION: Do not use compressed air or similar to clear dust or debris. Use of compressed air can cause equipment damage or failure.

Cooling Devices — Inspect the heatsink fan on the back side of the drive. Replace if the shaft does not turn freely, if blades are missing, or if the fan is not functioning properly. Apply power momentarily to check operation. If unit does not operate, replace fan as appropriate.

Predictive Maintenance for Drives — Predictive Maintenance with Logix PowerFlex 755 drives contain algorithms for Predictive Maintenance that are used to improve the uptime of machines, processes, and facilities. These algorithms monitor the lifespan of certain components. They can be used to alert personnel when the components are nearing the end of their lifespan so the components can be replaced before they fail.

There are algorithms for drive fans, relay contacts on digital outputs, motor bearings, motor lubrication, machine bearings, and machine lubrication. Parameter **00:469 [PredMaint Sts]** should be monitored by the Logix Controller in order to alarm the system of a impending Elapsed component Life threshold.

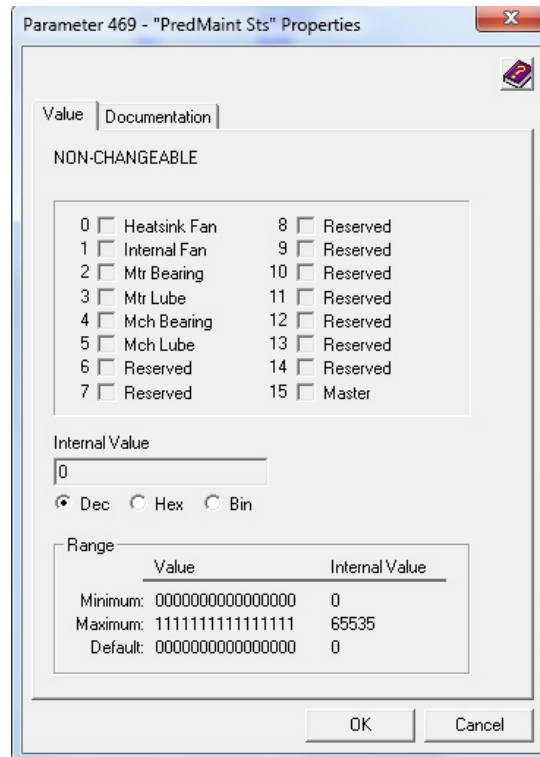

Predictive maintenance for drives is straightforward. Each predictive maintenance item has five key parameters. There are algorithms for drive fans, relay contacts on digital outputs, motor bearings, motor lubrication, machine bearings, and machine lubrication.

- [Total Life] is the total expected life of the component
- [Elapsed Life] is the amount of life that has been expended
- [Remaining Life] is the Total Life minus Elapsed Life
- [Event Level] is the amount of Elapsed Time (in percent of Total Life) when you want the drive to warn the user of an impending failure
- [Event Action] is the action set to take place when the drive reaches the Event Level. It can be set to the following options: Ignore, Alarm, Fault Minor, Fault Coast Stop, Fault Ramp Stop, or Fault Current Limit Stop.

TIP Set parameters **00:488...00:519** appropriately for desired status reporting in **00:469 [PredMaint Sts]**.

The alarm and fault actions stop the drive or prevent it from starting. If using a controller and a network interface such as EtherNet/IP, the logic and notification can be handled at the controller level. Configure the [Life Event Action] parameter to Alarm and use the controller to monitor the **00:469 [PredMaint Sts]** parameter.

See PowerFlex 750-Series AC Drives Programming Manual, publication [750-PM001](#) for details on the Predictive Maintenance parameter group in the Protection folder and programming examples. The design life expectancy of the overall components normally exceeds 10 years (in some cases it can last 20 years or more) in normal operating environments.

Operating Mechanisms — Check for proper functioning and freedom from sticking or binding. Replace any broken, deformed, or badly worn parts or assemblies according to individual product renewal parts lists. Check and securely re-tighten (if necessary) any loose fasteners. Lubricate (if specified) per individual product instructions.

IMPORTANT Allen-Bradley® magnetic starters, contactors, and relays are designed to operate without lubrication - do not lubricate these devices. Oil or grease on the pole faces (mating surfaces) of the operating magnet can cause the device to malfunction. Some parts of other devices are lubricated at the factory. If lubrication during use or maintenance of these devices is needed, it is specified in their individual instructions. If in doubt, consult the nearest Rockwell Automation sales office for information

Contacts — Check contacts for excessive wear and dirt accumulations. Discoloration and slight pitting are acceptable. Do not file contacts. Do not use contact spray cleaners, as residues can cause sticking or interfere with electrical continuity. Replace the contacts only after the silver has become badly worn. Always replace contacts in complete sets to avoid misalignment and uneven contact pressure.

Terminals — Loose connections can cause overheating that can lead to equipment malfunction or failure. Check the tightness of all terminals – securely tighten any loose connections. Replace any parts or wiring that is damaged by overheating. Also check ground connection integrity.

Coils—If a coil exhibits evidence of overheating (cracked, melted, or burned insulation), it must be replaced. In that event, check for and correct overvoltage or undervoltage conditions, which can cause coil failure. Be sure to clean any residues of melted coil insulation from other parts of the device or replace such parts.

High-Voltage Testing — Do not perform high-voltage insulation resistance (IR) and dielectric withstanding voltage (DWV) tests to check solid-state control equipment. When measuring IR or DWV of electrical equipment such as transformers or motors, a solid-state device that is used for control or monitoring must be disconnected before performing the test. Even though no damage is readily apparent after an IR or DWV test, the solid-state devices are degraded and repeated application of high voltage can lead to failure.

Final Check Out — After maintenance or repair of industrial controls, always test the control system for proper functioning under controlled conditions that avoid hazards if a control malfunction occurs.

Bus — For drives that are in storage and do not have a voltage that is applied, maintenance of the drive product can also be required (see [Figure 13](#)). For drives that are stored under 2 years, there is no additional maintenance required. For storage greater than 2 years, see [Table 9](#) for bus capacitor reforming requirements.

Table 9 - Drive Storage Duration and Reforming Recommendations

Duration	Reforming Guideline
Under 2 years	No reforming required.
2 ... 3 years	Apply rated voltage, per the normal method, for 30 minutes under no load.
Over 3 years	Using a DC power supply connected directly to the DC terminals of the product, ramp-up the voltage from 0 ... 100% of DC bus voltage (as per Table 10 DC Bus Voltage Ramp-up Values) in increments of 50%, 75%, and 100% rated voltage, under no load, for 30 minutes at each increment. See Figure 13 for an illustration of this method.

Table 10 - DC Bus Voltage Ramp-up Values

AC Input Voltage	Voltage Across the DC Bus
400/480V	680V DC

Figure 13 - Bus Capacitor Reforming Guidelines

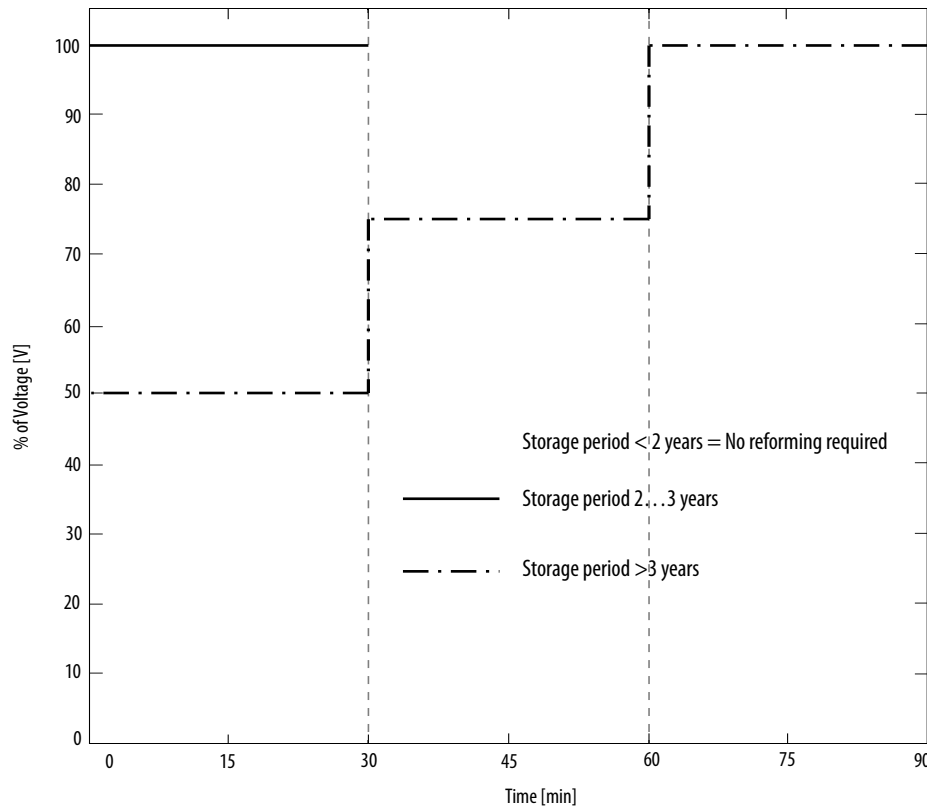

Receptacles and Cable Connectors— Check the tightness of all external cable connections that are made to the quick connectors on the bottom

enclosure plate. Cable connectors should be tightened hand-tight and receptacles should be to the specified torque values listed in the following table.

Terminal Designation	Description	Torque Value (lb-in)
L123	Input Power	60 ± 10%
T123	Output Power	60 ± 10%
DRB	Dynamic Brake	60 ± 10%
EMB1	400/480V AC Source Mechanical Brake	45 ± 10%
EMB2	24V DC Mechanical Brake	45 ± 10%
CP	24V DC Control Power	45 ± 10%
CPBR	24V DC Brake Power	45 ± 10%
DBRT	Brake Resistor Thermostat Temperature	45 ± 10%
S0	S0 Safety (S3)	45 ± 10%
S0	S0 Network Safety (S4)	45 ± 10%
S0	S0 Network Safety (S4 with brake)	45 ± 10%
S1	S1 Network Safety (S4)	45 ± 10%
P0	P0 Digital Input	45 ± 10%
P1	P1 Digital Input	45 ± 10%
CFBM	Allen-Bradley Servo Bulk Head Hiperface Encoder - Bulk head adapter	11 ± 10%
	Allen-Bradley Servo Bulk Head Hiperface Encoder - Mounting screws	25 ± 10%
CPBM	Allen-Bradley Servo Motor Power and Brake - Bulk head adapter	11 ± 10%
	Allen-Bradley Servo Motor Power and Brake - Mounting screws	25 ± 10%
ENCO	M23 Incremental Encoder	133 ± 10%
HIPSC	M23 Hiperface SC Encoder	133 ± 10%
SSIL	M23 SSI Linear Encoder	133 ± 10%
DENCO	M23 Dual Incremental Encoder - 0	133 ± 10%
DENC1	M23 Dual Incremental Encoder - 1	133 ± 10%
SSISC	M23 SSISC Rotary Encoder	133 ± 10%
ETH1	EtherNet/IP Link 1	20 ± 10%
ETH 2	EtherNet/IP Link 2	20 ± 10%

Solid-state Devices — Solid-state devices require a little more than a periodic visual inspection. Inspect the printed circuit boards to determine whether they are properly seated in the edge connectors. Board locking tabs must be in place. Necessary replacements must be made only at the personal computer board or plug-in component level. Do not use solvents on printed circuit boards. When blowers are used, air filters must be cleaned or changed periodically depending on the specific environmental conditions encountered.



ATTENTION: Use of other than factory recommended test equipment for solid-state controls can result in damage to the control or test equipment or unintended actuation of the controlled equipment.

Locking and Interlocking Devices — Check these devices for proper working condition and capability of performing their intended functions.

Maintenance After a Fault Condition — An open short circuit protective device (such as a fuse or circuit breaker) in a properly coordinated motor branch circuit is an indication of a fault condition in excess of operating overload. Such conditions can damage control equipment. Before restoring power, the fault condition must be corrected and any necessary repairs or replacements must be made to restore the control equipment to good working order. Make sure that the parts are properly matched to the model, series, and revision level of the equipment.

Keep Good Maintenance Records — This rule is most helpful to locate possible intermittent problems by pointing to a particular area of constant trouble within the overall system. Furthermore, good maintenance records reduce major costly shutdowns by demanding the use of proper test equipment and an appropriate inventory of spare parts.

We recommend that a complete record of parameter settings be kept close to the drive for future reference. Some drives also incorporate an operator interface that can store a copy of the parameter setting.

IMPORTANT Duty cycle, load profile, temperature, altitude, incoming line conditions, and other operating/environmental conditions greatly affect reliability of a drive.

Table 11 - Recommended Drives Maintenance Tasks and Schedule

Years >		0	1	2	3	4	5	6	7	8	9	10	11	12	13	14	15	16	17	18	19	20	
Components and Activities																							
Air-cooling System	Main Heatsink Fan Assembly ⁽¹⁾⁽²⁾		I	I	I	I	R	I	I	I	I	R	I	I	I	I	R	I	I	I	I	I	R
Terminal Wiring	Cables and Connectors		I/M	I/M	I/M	I/M	I/M	I/M	I/M	I/M	I/M	I/M	I/M	I/M	I/M	I/M	I/M	I/M	I/M	I/M	I/M	I/M	I/M
Enhancements	Firmware		-	-	Rv	-	-	Rv	-	-	Rv	-	-	Rv	-	-	Rv	-	-	Rv	-	-	
	Hardware		-	-	Rv	-	-	Rv	-	-	Rv	-	-	Rv	-	-	Rv	-	-	Rv	-	-	
Operational Conditions	Parameters		I	I	Rv	I	I	Rv	I	I	Rv	I	I	Rv	I	I	Rv	I	I	Rv	I	I	
	Application Concerns ⁽³⁾		I	I	Rv	I	I	Rv	I	I	Rv	I	I	Rv	I	I	Rv	I	I	Rv	I	I	
Spare Parts	Spare Parts and Inventory/Needs ⁽⁴⁾		I	I	Rv	I	I	Rv	I	I	Rv	I	I	Rv	I	I	Rv	I	I	Rv	I	I	
Internal Components	Electrical wiring ⁽⁵⁾		I	I	I	I	I	I	I	I	I	I	I	I	I	I	I	I	I	I	I	I	
Covers / Doors	Seals		I	I	I	I	R	I	I	I	I	R	I	I	I	I	R	I	I	I	I	R	
Ground	Ground		I	I	I	I	I	I	I	I	I	I	I	I	I	I	I	I	I	I	I	I	

- (1) Inspect and clean screens every 3 months or more frequently, depending on the environment.
- (2) Use **00:469 [PredMaint Sts]** to monitor predictive maintenance for the Frame 2 drive.
- (3) See Wiring and Grounding Guidelines for Pulse-width Modulated (PWM) AC Drives, publication [DRIVES-IN001](#).
- (4) See the associated chapter or section for the list of parts.
- (5) Inspect wire connections.

Spare Parts Directory

Topic	Page
Induction Motor 400/480 AC Source Brake	203
Induction Motor 24V DC Mechanical Brake	204
Servo Motor 24V DC Mechanical Brake	205
Gland Plate Receptacles	206

Induction Motor 400/480 AC Source Brake

Schematic Symbol	Part Description	Catalog Number
1EA030 ⁽¹⁾	PowerFlex 755 Drive (Note 1)	20G11F****AA0NNNNN
1CH030	PowerFlex 750, Frame 2 EMC Kit	20-750-EMC1-F2
1CH031	1321 Common Mode Code	1321-M055
1EA030_ENCODER	PowerFlex 750 Encoder Option Module	20-750-ENC-1
1EA030_DENCODER	PowerFlex 750 Dual Encoder Option Module	20-750-DENC-1
1EA030_UFM	PowerFlex 750 Universal Feedback Module	20-750-UFB-1
1EA030_STO	PowerFlex 750 Network Safe Torque-Off Module	20-750-S3
1EA030_SSM	PowerFlex 750 Integrated Network Safety Functions Module	20-750-S4
1EA030_I/O	PowerFlex 750 24V DC 1R2T I/O Module	20-750-2263C-1R2T
1EA030_APS	PowerFlex 750 Auxiliary Power Supply Module	20-750-APS
1HIM320	PowerFlex IP66 / UL Type 4X Human Interface Module (HIM)	20-HIM-C6S
1CB030	140G 125A Molded Case Circuit Breaker	140G-G6C3-C30-AJ
1CB250	140M Brake Circuit Breaker	140M-C2E-B25
1CB250_AUX	140M Breaker Auxiliary Contact	140M-C-AFA10
5BC130	IEC 9A Brake Contactor	100-C09EJ10
5BC130_SUP	Contactor, Coil Surge Suppressor	100-FSD250
5BC130_AUX	Contactor, Auxiliary Contact	100-SB01
1SUP270 ⁽²⁾	Brake Contact, RC Suppressor	ELECTROCUBE-RG1676-16
5CB070	4A Circuit Breaker	1489-M2D040
6ET210	Ethernet I/P Tap, 3 Port	1783-ETAP
ENET_DRIVE	RJ45 Ethernet Media	1585J-M4TBJM-1

(1) Refer to the drive data nameplate or Tables 1 or 2 on the schematics to select the drive size.

(2) Contact your local distributor to order an Electrocube component.

Induction Motor 24V DC Mechanical Brake

SCHEMATIC SYMBOL	PART DESCRIPTION	CATALOG NUMBER
1EA030 ⁽¹⁾	PowerFlex 755 Drive (Note 1)	20G11F****AA0NNNNN
1CH030	PowerFlex 750, Frame 2 EMC Kit	20-750-EMC1-F2
1CH031	1321 Common Mode Code	1321-M055
1EA030_ENCODER	PowerFlex 750 Encoder Option Module	20-750-ENC-1
1EA030_DENCODER	PowerFlex 750 Dual Encoder Option Module	20-750-DENC-1
1EA030_UFM	PowerFlex 750 Universal Feedback Module	20-750-UFB-1
1EA030_STO	PowerFlex 750 Network Safe Torque-Off Module	20-750-S3
1EA030_SSM	PowerFlex 750 Integrated Network Safety Functions Module	20-750-S4
1EA030_I/O	PowerFlex 750 24V DC 1R2T I/O Module	20-750-2263C-1R2T
1EA030_APS	PowerFlex 750 Auxiliary Power Supply Module	20-750-APS
1HIM320	PowerFlex IP66 / UL Type 4X Human Interface Module (HIM)	20-HIM-C6S
1CB030	140G 125A Molded Case Circuit Breaker	140G-G6C3-C30-AJ
5CB130	1489 Miniature Circuit Breaker	1489-M2D040
5CB130_AUX	1489 Miniature Circuit Breaker Auxiliary Contact	1489-AMRA3
5BC130	IEC 9A Brake Contactor	100-C09EJ10
5BC130_SUP	Contactor, Coil Surge Suppressor	100-FSD250
5BC130_AUX	Contactor, Auxiliary Contact	100-SB01
1BD270	Brake Contact, RC Suppressor	199-MSMD1
5CB070	4A Circuit Breaker	1489-M2D040
6ET210	Ethernet I/P Tap, 3 Port	1783-ETAP
ENET_DRIVE	RJ45 Ethernet Media	1585J-M4TBJM-1

(1) Refer to the drive data nameplate or Tables 1 or 2 on the schematics to select the drive size.

Servo Motor 24V DC Mechanical Brake

SCHEMATIC SYMBOL	PART DESCRIPTION	CATALOG NUMBER
1EA030 ⁽¹⁾	PowerFlex 755 Drive (Note 1)	20G11F****AA0NNNNN
1CH030	PowerFlex 750, Frame 2 EMC Kit	20-750-EMC1-F2
1EA030_ENCODER	PowerFlex 750 Dual Encoder Option Module	20-750-DENC-1
1EA030_UFM	PowerFlex 750 Universal Feedback Module	20-750-UFB-1
1EA030_STO	PowerFlex 750 Network Safe Torque-Off Module	20-750-S3
1EA030_SSM	PowerFlex 750 Network Integrated Network Safety Functions Module	20-750-S4
1EA030_I/O	PowerFlex 750 24V DC 1R2T I/O Module	20-750-2263C-1R2T
1EA030_APS	PowerFlex 750 Auxiliary Power Supply Module	20-750-APS
1HIM320	PowerFlex IP66 / UL Type 4X Human Interface Module (HIM)	20-HIM-C6S
1CB030	140G 125A Molded Case Circuit Breaker	140G-G6C3-C30-AJ
5CB130	1489 Miniature Circuit Breaker	1489-M2D040
5CB130_AUX	1489 Miniature Circuit Breaker Auxiliary Contact	1489-AMRA3
5BC130	IEC 9A Brake Contactor	100-C09EJ10
5BC130_SUP	Contactor, Coil Surge Suppressor	100-FSD250
5BC130_AUX	Contactor, Auxiliary Contact	100-SB01
1BD270	Brake Contact, RC Suppressor	199-MSMD1
5CB070	4A Circuit Breaker	1489-M2D040
6ET210	Ethernet I/P Tap, 3 Port	1783-ETAP
ENET_DRIVE	RJ45 Ethernet Media	1585J-M4TBJM-1

(1) Refer to the drive data nameplate or Tables 1 or 2 on the schematics to select the drive size.

Gland Plate Receptacles

SCHEMATIC SYMBOL	PART DESCRIPTION	CATALOG NUMBER
L123	Input Power Receptacle,IN1,M35,4 Pin	SK-26G-RCPT-L123-M35-4
T123	Output Power Receptacle,M29,4 Pin	SK-26G-RCPT-T123-M29-4
DBR	Dynamic Brake Receptacle,M29,4 Pin	SK-26G-RCPT-DBR-M29-4
T123	Output Power Receptacle,M35,4 Pin	SK-26G-RCPT-T123-M35-4
DBR	Dynamic Brake Receptacle,m35,4 Pin	SK-26G-RCPT-DBR-M35-4
EMB1/EMB2	Mechanical Brake Receptacle,m24,3 Pin	SK-26G-RCPT-EMB1-2-M24-3
CP	24V DC Control Power Recep,Mini,4 Pin	SK-26G-RCPT-CP-MINI-4
CPBR	24C DC Brake Power Recep,Mini,4 Pin	SK-26G-RCPT-CPBR-MINI-4
S0	S0 Network Safety Recep,A,Micro,5 Pin	SK-26G-RCPT-S0-A-MICRO-5
S0	S0 Network Safety Recep,B,Micro,5 Pin	SK-26G-RCPT-S0-B-MICRO-5
S1	S1 Network Safety Recep,B&C,Micro,5 Pin	SK-26G-RCPT-S1-B-C-MICRO-5
S0	S0 Network Safety Recep,C,Micro,5 Pin	SK-26G-RCPT-S0-C-MICRO-5
P0	P0 Digital Input Receptacle,Micro,5 Pin	SK-26G-RCPT-P0-MICRO-5
P1	P1 Digital Input Receptacle,Micro,5 Pin	SK-26G-RCPT-P1-MICRO-5
DBRT	Brake Res Thstat Temp Recep,Micro,4 Pin	SK-26G-RCPT-DBRT-MICRO-4
ETH1/ETH2	Micro D-code, QD Style Ethernet Media	1585D-D4TBJM-0M3
ENCO	INC Encoder Receptacle,M23,12 Pin,E41	SK-26G-RCPT-ENCO-E41-M23-12
HIPSC	HIPSC Encoder Receptacle,M23,12 Pin,E42	SK-26G-RCPT-HIPSC-E42-M23-12
SSISC	SSI SC Rotary Encoder Recp,M23,12 P,E43	SK-26G-RCPT-SSISC-E43-M23-12
DENCO	Dual INC Encoder 0 Recp,M23,12 Pin,E44	SK-26G-RCPT-DENCO-E44-M23-12
DENC1	Dual INC Encoder 1 Recp,M23,12 Pin,E44	SK-26G-RCPT-DENC1-E44-M23-12
HIPSC	HIPSC Encoder Recp,M23,12 Pin,E51,E53	SK-26G-RCPT-HIPSC-E51-3-M23-12
SSIL	SSI LIN Encr Recp,M23,12 Pin,E53,E54,E55	SK-26G-RCPT-SSIL-E53-4-5-M23-12
SSISC	SSI SC Rotary Encoder Recp,M23,12 P,E56	SK-26G-RCPT-SSISC-E56-M23-12
CPBM ⁽¹⁾	Output Pwr,#10 & Brake,#18, Recp,6 Pin	SK-26G-RCPT-CPBM-P10-B18-6
	Mp-series Cable Bulkhead Adapter, 06CF	2090-KPB47-06CF ⁽⁴⁾
CPBM ⁽²⁾	Output Pwr,#14 & Brake,#18, Recp,6 Pin	SK-26G-RCPT-CPBM-P14-B18-6
	Mp-series Cable Bulkhead Adapter, 12CF	2090-KPB47-12CF ⁽⁵⁾
CFBM ⁽³⁾	HIPSC Encoder Recp. Servo bulk H,E52,E55	SK-26G-RCPT-HIPSC-E52-5-M23-17
	Mp-series Cable Bulkhead Adapter, CF	2090-KFB47-CF ⁽⁶⁾

(1) Use with SK-26G-RCPT-CPBM-P10-B18-6.

(2) Use with SK-26G-RCPT-CPBM-P14-B18-6.

(3) Use with SK-26G-RCPT-HIPSC-E52-5-M23-17.

(4) This is a flange adapter to mount the receptacle SK-26G-RCPT-CPBM-P10-B18-6 on the gland plate.

(5) This is a flange adapter to mount the receptacle SK-26G-RCPT-CPBM-P14-B18-6 on the gland plate.

(6) This is a flange adapter to mount the receptacle SK-26G-RCPT-HIPSC-E52-5-M23-17 on the gland plate.

Start Up Information

Prepare for Initial Drive Start Up

Gather the following information before proceeding to start up. It is recommended to print this page and keep it available during the start up process.

Motor Data ^{(1) (2)}		Dynamic Brake Data		Option Module: Safety		Stop Mode		Application Specifics	
Hp/Kw		Ohms		(A) S3 Safe Torque Off – Hardwired		Coast		Accel Rate	
Hertz		Watts		(A) S3 Safe Torque Off – Integrated Safety		Ramp Stop		Decel Rate	
RPM		Watts/sec (joules)		(B) S4 Integrated Safe Speed Monitoring		Current Limit		S Curve	
Volts				(C) S4 Integrated Safe Speed Monitoring with Source Brake				Horizontal / Vertical	
Amps		Mechanical Motor Brake Data		(N) None		Port Assignment		Max Velocity	
# Motor Poles		Current				Position Loop			
		Amps				Speed Loop		Motor Polarity	
		Voltage	24V DC or 400/480 V AC			Universal Feedback Port		Forward Direction	
Ethernet/IP address								Reverse Direction	
Firmware Revision^{(3) (4)}				Drive Catalog Number⁽⁴⁾					
Drive Rating⁽⁴⁾				Add-on Profile Version					
Option Module Port Assignment⁽⁵⁾	Port 4	Port 5		Port 6		Port 7		Port 8	
						20-750-2263C-1R2T		20-750-APS	

- (1) The motor data must be entered in Kw when doing installation for integrated motion. (Kw=Hp*0.746)
- (2) If an Allen Bradley permanent magnet servo motor is being used (versus an induction motor), you must look up the AB servo motor part number. Refer to PowerFlex 750-Series AC Drives Technical Data, publication [750-TD001](#) to obtain proper VFD drive settings for the motor being controlled.
- (3) Get help determining how products interact, check features and capabilities, and find associated firmware <https://compatibility.rockwellautomation.com/Pages/home.aspx>. For additional information on how to update drive firmware, see the [Troubleshooting](#) chapter of this manual.
- (4) Firmware version, drive catalog number, and drive ratings are located on the data name plate. Additional information about the option modules and their slots are located in the electrical schematics.
- (5) Slot 4, 5, and 6 are specific to your application. The option module used is identified in the catalog string definition. See [Catalog Number Explanation on page 16](#) for more information.

Notes:

Numerics

- 1756-L73S controller** 59
- 1783-ETAP** 50
- 20-750-2263C-1R2T** 121
- 20-750-S3** 57, 124
- 20-750-S4** 57, 124
- 24V DC** 12, 161
 - circuit breaker 44
 - control power 44, 161, 170
 - energize 52
 - pinout 44
- 400/480V AC** 153, 170
 - cycle power 25
 - line power 12, 22 . . . 26, 96, 170

A

- access HIM cable** 149
- adapter**
 - firmware update 191
 - parameter use 53, 185, 188
 - reset 185, 187
 - resetting 187
 - restore parameters 190
 - status parameter 185, 190
 - status webpages 185
- add drive to network** 60, 112
- additional resource** 8, 51, 112
- add-on profile** 57
- application tuning** 108
- Armor GuardLogix** 57, 124
- ArmorConnect** 15, 25, 39
- Autotune** 97
 - 00|70 Autotune 100
 - I/O mode
 - See startup wizard
- autotune**
 - integrated motion 138, 142
 - position loop, integrated motion 142
 - velocity loop, integrated motion 142
- auxiliary circuit breaker door** 12, 176
- axis**
 - configure 117
 - creation, integrated motion 117
 - motion group 116
 - properites, integrated motion 127
 - scheduling 126
- axis association** 116, 127
- axis rotation** See motor

B

- BOOTP** 50, 53
 - disabling 54
- brake** 25, 151, 176
 - contactor 152
 - troubleshooting 175
 - mechanical brake 96
 - source brake 25, 161, 176
- branch circuit protection** 23, 176, 202
 - requirement 25
- bus capacitor**
 - discharge 17
 - reforming 29
 - voltage check 178

C

- cabinet rating** 20
- cable** 39
 - connection 45
 - guidelines 20
 - HIM 149
 - installation 20
 - interface connection 44, 45
 - interface receptacle 38
 - motor cable 38
 - motor cable length 38
 - pinout 48
 - power media cable 25
 - rating 21, 25
 - receptacle 38
 - receptacle pinout 38, 44, 47
 - SEW cable 39
 - tray 20
- catalog number explanation** 16
- circuit breaker** 25, 26, 153, 161
 - 24V DC 44, 170
 - 400/480V AC 153, 170
 - door 12, 176
 - energize 52, 96, 170
 - mechanical brake, DC 25, 52, 96, 161, 176
 - open door 146, 147
 - replace 161
 - reset 176
 - source brake, AC 25, 52, 161, 176
 - troubleshooting 175
- communication**
 - add drive to network 60
 - disable BOOTP 53
 - going online troubleshooting 185
 - rate 55
 - replace ETAP 163
 - set 1783-ETAP 50, 163
 - set data rate 55
 - set gateway address 54, 190
 - set I/P address 53
 - set IP address 54
 - using adapter parameter 53
- Compact GuardLogix** 57, 59, 124
- configure axis** 117, 124, 127

connection
 cable 38, 39, 47, 170
 type 67

connector
 mating 38
 pinout 48

control power 44

controller 57, 112, 124
 command control word 80
 organizer 67, 88

cover
 circuit breaker 25, 52
 open circuit breaker door 146, 147
 remove cover 148

D

data nameplate 12 . . . 13
 catalog number 16

data rate
 set 55

datalink 81, 85, 89

DC bus
 maintenance 28, 29
 voltage check 178

delta-Wye solid ground 22

DHCP 50

diagram
 system exterior 12
 system interior 146

digital input
 I/O mode 80
 integrated motion 120

digital output
 I/O mode 82
 integrated motion 121

dimension 27, 29

direction test 104

direction verification 104

download project 92, 135

drive
 attach cover 169
 identification 16
 integrity check 184
 peripheral device 16, 114
 port assignment, integrated motion 118
 storage 28, 29

duplex communication mode
 selecting 55

dynamic brake 51, 119

dynamic motor test
 integrated motion 140

E

electrical safety consideration 19, 173

electromagnetic compatibility (EMC) 21, 37
 general note 21
 wiring 22

electrostatic discharge (ESD) 20

embedded EtherNet/IP 51

EMC kit 163

EMI filter 21

encoder
 mechanical checks 180, 181
 system components 180

encoder feedback
 troubleshooting 175, 179

end of life (EOL) 19

environment 20

environment and enclosure 19

environmental conditions 20

error. See fault

ETAP 163
 maintenance 163

ethernet
 ETAP 50
 IP address 54

ethernet. See communication

F

fan
 maintenance 160

fault
 action
 configuring the adapter 188
 configuration
 configuring the adapter 189
 maintenance 202
 set action 187
 troubleshooting 174

feedback device. See option module

feeder circuit protection 23, 24

firmware
 requirement 57, 124
 update 191

freight damage 30

fuse 8, 25, 202

G

gain tuning, integrated motion 129

gateway address, set 54, 190

gland plate
 abbreviation 47
 configuration 44
 configuration option 45
 option 44
 receptacle 44

go online 93, 137, 185
 troubleshooting 185

ground
 earth ground 36
 EMI filter 21
 PE or ground 38
 safety ground 37

grounding 12, 23, 149, 170, 181

- EMI filter 21
- PE or ground 38
- safety grounds 37

GuardLogix 57, 59, 124

H

hard-wired safety 67

HIM 12

- 20-HIM-C6S HIM 53
- accessing parameters with 53
- cable disconnect 149
- change the language 52
- energize 51
- using the HIM 52

hoisting 12, 31

hold last

- configuring the adapter 188

I

I/O mode

- application tuning 108
- connect motor 109
- datalink 81, 85, 89
- digital inputs 80
- digital output 82
- direction test 104
- EtherNet/IP Seestart up wizard
- inertia tune 102
- input parameter 85
- jog 104
- output parameter 85
- performance tuning 108
- rotate tune 102
- safety connection type 67
- save and download project 92
- start up wizard 72
- start/stop 80
- synchronize drive 110

I/O mode startup 59

- when to use 56

I/O option module 160

I/P address

- set 53

induction motor

- 24V DC brake (15.4 amps) 45
- 24V DC brake (22 amps) 45
- source brake (15.4 amps) 45
- source brake (22 amps) 46

inertia tune

- I/O mode 102

inspect 30

installation

- cable 38, 39, 47, 170
- label 34
- lift and transport 31
- mount drive 35
- overview 17
- precaution 17
- receive, unpack, inspect 28, 30
- receptacle pinout 48

integrated motion 112, 130

- add axis to motion group 125
- add drive 112
- axis association 116
- base update period 125
- go online 137
- I/O project 112
- module properties 112
- motor and feedback test 140
- motor polarity 141
- save and download 135
- set base update period 126

Integrated Motion startup 112

- when to use 56

Integrated Safe Torque Off Module 57, 124

Integrated Safety Function 57, 124

- controller requirement 57, 96, 124
- definition 11, 16
- integrated safety 67
- logic 86

IP address 53

- See communication
- set 50, 54

J

jumper configuration 37

L

label 12, 34

lift and transport 12, 31, 33

lifting 12, 32, 36

- acceptable equipment 31
- lifting hole 31
- two-person lift 33

Logix Controller 56, 93

Logix Designer application 56

M

machine

- apply power 170
- attach cover 169
- attention 18
- description 11
- dimension 27, 29
- drive storage 28
- identification 12 . . . 13
- inspection 28, 30
- integrated motion start up 112
- integration 13
- maintenance schedule 202
- mounting clearance 28
- preventative maintenance 195
- product rating 11, 19
- shipping damage 30
- system configuration 13
- weight 29

maintenance 145

- 24V DC breaker 161
- 400/480V AC power 25
- apply power 170
- attach cover 169
- auxiliary circuit breaker 161
- brake contactor 152
- check DC bus voltage 178
- EMC kit 163
- ETAP 163
- faults 174
- Frame 2 156
- gland plate 164
- heat sink fan 160
- main circuit breaker 153
- mechanical break circuit breaker 161
- option module 160
- PowerFlex 755, Frame 2 156 . . . 159
- preventative 195
- receptacle torque 200
- record keeping 202
- remove front cover 148
- replace receptacle 164
- reset circuit breaker 176
- schedule 202
- source break circuit breaker 161
- surge suppressor
 - AC source brake 25, 52, 150, 172, 177
 - DC brake 25, 52, 151, 172, 177
- task list 202

manual tune, integrated motion 143**measurements** 27, 32, 36**mechanical brake** 25, 52, 96

- circuit breaker, DC 161

minimum mounting clearance 28**module properties**

- I/O mode 63
 - drive parameter 72
 - import template file 63
 - manual entry 63
 - safety 67
 - verify data 66
- integrated motion
 - add drive 112

motion group 116

- add axis, integrated motion 125
- create, integrated motion 123
- properites, integrated motion 123
- update period, integrated motion 125

motor

- cable 38
- cable length 38
- configuration, integrated motion 130
- connect motor, I/O mode 109
- data source 130
- jog 104
- motion group, integrated motion 123
- motor control, I/O mode 74
- motor polarity 141
- RS Trend 88
- tuning, I/O mode 97
- tuning, integrated motion 138

motor and feedback test 140**mount the packaged drive** 35**mounting** 12, 28

- environment 36
- hole location 35

mounting clearance 28**N****NEMA rating** 20**network safety. See safety****network** 50**O****operating temperature** 20**option module**

- 20-750-2263C 121
- port assignment 118
- replacement 157
- slot assignment 114, 157
- universal feedback device 74

P**package content** 30**parameter**

- 00|11 DC Bus Volt 96, 178
- 00|125 Pri Vel Fdbk Sel 99, 107, 183
- 00|126 Pri Vel Fdbk Fltr 183
- 00|128 Alt Vel Fdbk Sel 99
- 00|130 Alt Vel Feedback 104
- 00|131 Active Vel Fdbk 104
- 00|135 Psn Fdbk Sel 183
- 00|137 Open Loop Fdbk 99, 183
- 00|25 Motor NP Volts 184
- 00|26 Motor NP Amps 184
- 00|31 Motor Poles 184
- 00|35 Motor Ctrl Mode 183
- 00|363 FS Reconnect Dly 185
- 00|469 PredMaint Sts 198, 202
- 00|636 Speed Reg BW 108, 183, 184, 185
- 00|645 Speed Reg Kp 184
- 00|647 Speed Reg Ki 184
- 00|660 SReg Output 107
- 00|690 Limited Tqr Ref 184
- 00|70 Autotune 99
- 00|71 Autotune Torque 101
- 00|73 IR Voltage Drop 101
- 00|74 Ixo Voltage Drop 101
- 00|75 Flux Current Ref 184
- 00|781 PTP Accel Time 183
- 00|782 PTP Decel Time 183
- 00|787 PTP S Curve 183
- 00|838 Psn Reg Ki 183
- 00|839 Psn Reg Kp 108
- 00|919 Stop Owner 182
- 00|933 Start Inhibit 175, 182
- 00|935 Drive Status 1 83
- 00|945 At Limit Status 184
- 00|951 Last Fault Code 184

- 04|04 Enc 0 FB 111
 - 04|14 Enc 1 FB 111
 - 05|05 FBO Position 98, 99
 - 05|08 FBO Cfg 105
 - 07|01 Dig In Sts 85, 96, 122, 171, 175
 - 07|06 Digital Out Invert 175
 - 07|10 Relay Out 0 175
 - 07|20 Transistor Output 0 175
 - 13|34 DLs From Net Act 185
 - 13|35 DLs To Net Act 185
 - 13|36 BOOTP 53, 185
 - 13|37 Net Addr Src 54
 - 13|38 IP Addr Cfg 1...13|41 IP Addr Cfg 4
54, 185, 190
 - 13|42 Subnet Cfg 1...13|45 Subnet Cfg 4 54,
190
 - 13|46 Gateway Cfg 1...13|49 Gateway Cfg 4
55, 190
 - 13|50 Net Rate Cfg 55, 190
 - 13|51 Net Rate Act 185
 - 13|52 Web Enable 186
 - 13|53 Web Features 186
 - 13|54 Comm Flt Action 188
 - 13|55 Idle Flt Action 188
 - 13|56 Peer Flt Action 188
 - 13|57 Msg Flt Action 188
 - 13|58 Flt Cfg Logic 188
 - 13|59 Flt Cfg Ref 188
 - 13|60 Flt Cfg DL 01...
13|75 Flt Cfg DL 16 188
 - 13|60 Flt Cfg DL 01...13|75 Flt Cfg DL 16 189
 - 13|77 DLs Fr Peer Act 185
 - 13|86 Fr Peer Status 185
 - 13|88 DLs To Peer Act 185
 - access parameter 53
 - adapter status 185, 188
 - adapter web pages 185
 - configure drive parameter 72
 - convention 7
 - definition 7
 - I/O mode
 - input parameter 85
 - output parameter 85
 - reset adapter 187
 - restoring to factory default values 190
 - tuning 97
 - using adapter parameter 53, 185
 - xx|05 FBO Position 111
 - xx|09 FBO Loss Cfg 184
 - xx|25 FBO Lin CPR 111, 183
 - xx|55 FB1 Lin CPR 183
- parameters**
restore adapter parameter 190
- part number** 16
- password** 186
- performance tuning** 108
- peripheral device. See option module**
- pin identification** 48
- pinout receptacle** 48
- point-to-point (PTP)** 79, 108, 149
- port assignment**
integrated motion 118
- position feedback**
troubleshooting 182
- power**
24V DC 12, 24, 44, 161, 178
400/480V AC 12, 25, 96, 153, 170
apply power 170
ArmorConnect 15
attention 18, 23
branch circuit protection 176, 202
circuit breaker 25
circuit protection, branch 23, 25
circuit protection, feeder 23, 24
control power 24, 161
electrical safety consideration 173
faults 174
lock out and tag out 146, 147
PE ground 12, 23, 37
remove 146, 147
requirement 22
reset circuit breaker 176
short-circuit rating (SCCR) 24
voltage check 178
warning 18, 23
- PowerFlex 755**
attach cover 169
configure axis 124, 127
configure axis, integrated motion 116
create axis 117
EMC kit 163
faults and alarms 174
Frame 2 156
heatsink fan 160
removal 9, 158
HIM cable 156
option module 157
replacement 160
remove cover 156
update firmware 191
web pages 185
- preventative maintenance** 195
- program mode**
I/O mode 93
integrated motion 137
- protection. See safety**
- publication reference** 8
- R**
- real-time clock** 197
- receive** 28
- receptacle**
abbreviation 47
cable 38
connector 38, 39, 170
gland plate 164
mating 39
pinout 48
replacement 164
torque 200
- record maintenance** 202
- reference manual** 8
- reference material** 51
- relative humidity** 20
- remote run mode** 95
- remove cover** 148

- remove power** 147
- reset circuit breaker** 176
- resetting the adapter** 187
- rFlex** 138
- rotate tune**
 - I/O mode 102
- RS Trend** 88, 109
 - properties 89

- S**
- Safe Torque Off**
 - controller requirement 57, 96, 124
 - definition 11
 - logic 86
- safety commissioning** 96
- safety ground** 23
- safety option module**
 - 20-750-S3 module 57, 124
 - 20-750-S4 module 57, 124
 - compatibility 11
 - connection type 67
 - logic 86
 - safety program, I/O mode 67
 - safety program, integrated motion 135
 - troubleshooting 175
- safety product manuals** 9
- save and download project**
 - I/O mode 92
 - integrated motion 135
- save project** 92, 135, 144
- schedule**
 - maintenance 202
- scheduling**
 - axis 126
- servo motor**
 - 24V DC (14 amps) 46
 - 24V DC brake (22 amps) 46
- set fault action** 187
- SEW cable** 39
- shipping damage** 30
- short-circuit rating (SCCR)** 24
- source brake**
 - circuit breaker 25
- source brake, AC** 52, 161
- start up** 50
 - add-on profile 57
 - apply power 170
 - determine mode 56
 - electrical power consideration 173
 - faults 174
 - I/O mode 59
 - add drive to network 60
 - application tuning 108
 - auto tune 97
 - connect motor 109
 - datalink 89
 - direction test 104
 - go online 93
 - inertia tune 102
 - performance tuning 108
 - remote run 95
 - rotate tune 102
 - safety logic 86
 - save and download project 92
 - static tune 97
 - synchronize drive 110
 - trend 88
- integrated motion 112
 - add axis to motion group 125
 - add drive 112
 - autotune 142
 - axis association 116
 - axis creation 117
 - axis scheduling 126
 - create motion group 123
 - digital input 120
 - digital outputs 121
 - dynamic motor test 140
 - gain tuning 129
 - go online 137
 - I/O project 112
 - manual tune 143
 - module properties 112
 - motor and feedback test 140
 - motor data source 130
 - motor polarity 141
 - option module 114, 160
 - power options 118
 - safety program 135
 - save and download project 135
 - save project 144
 - slot assignment 160
 - static motor test 139
 - tuning 142 . . . 143
- mode choice 55
- prepare for 50, 51, 207
- wizard, start up wizard 72
- start up
 - integrated motion
 - tuning 138
- static tune**
 - I/O mode 97
- storage temperature** 20
- stored drive** 29
- Studio 5000 Logix Designer Application** 56
- subnet mask, set** 54
- surge suppressor**
 - AC source brake 150
 - DC brake 151
- synchronize the drive** 110
- system configuration** 13

T

three-phase power. *See* power

trend properties 89

troubleshooting 173

brake contactor 174, 175

circuit breakers 178

encoder feedback 179

fault 174, 188

fault action 187

grounding 181

positioning 182

tuning

application tuning 108

autotune 97, 142

direction test 104

gain tuning 129

inertia tune 102

integrated motion 138

jog mode 104

motion system 112

motor auto tune 97

parameter 97

performance 108

rotate tune 102

static tune 97

velocity and position 143

U

UL rating 20

unpack 30

upkeep 145

V

voltage check 178

W

weight 29

wiring 22

wiring and workmanship guidelines 20

wizard 72

Z

zero data

configuring the adapter 188

Notes:

Rockwell Automation Support

Use these resources to access support information.

Technical Support Center	Find help with how-to videos, FAQs, chat, user forums, and product notification updates.	rok.auto/support
Knowledgebase	Access Knowledgebase articles.	rok.auto/knowledgebase
Local Technical Support Phone Numbers	Locate the telephone number for your country.	rok.auto/phonesupport
Literature Library	Find installation instructions, manuals, brochures, and technical data publications.	rok.auto/literature
Product Compatibility and Download Center (PCDC)	Get help determining how products interact, check features and capabilities, and find associated firmware.	rok.auto/pcdc

Documentation Feedback

Your comments help us serve your documentation needs better. If you have any suggestions on how to improve our content, complete the form at rok.auto/docfeedback.

Waste Electrical and Electronic Equipment (WEEE)



At the end of life, this equipment should be collected separately from any unsorted municipal waste.





Rockwell Automation maintains current product environmental information on its website at rok.auto/pec.

Allen-Bradley, ArmorBlock, ArmorConnect, ArmorStart, Connected Components Workbench, ControlFLASH, DriveExecutive, DriveExplorer, expanding human possibility, Guard I/O, Kinetix, Logix, On-Machine, PowerFlex, Rockwell Automation, Rockwell Software, and Studio 5000 Logix Designer are trademarks of Rockwell Automation, Inc.

EtherNet/IP is a trademark of ODVA, Inc.

Trademarks not belonging to Rockwell Automation are property of their respective companies.

Rockwell Otomasyon Ticaret A.Ş. Kar Plaza İş Merkezi E Blok Kat:6 34752, İçerenköy, İstanbul, Tel: +90 (216) 5698400 EEE Yönetmeliğine Uygundur

Connect with us.    

rockwellautomation.com ————— **expanding human possibility™**

AMERICAS: Rockwell Automation, 1201 South Second Street, Milwaukee, WI 53204-2496 USA, Tel: (1) 414.382.2000, Fax: (1) 414.382.4444

EUROPE/MIDDLE EAST/AFRICA: Rockwell Automation NV, Pegasus Park, De Kleetlaan 12a, 1831 Diegem, Belgium, Tel: (32) 2 663 0600, Fax: (32) 2 663 0640

ASIA PACIFIC: Rockwell Automation, Level 14, Core F, Cyberport 3, 100 Cyberport Road, Hong Kong, Tel: (852) 2887 4788, Fax: (852) 2508 1846