

CRITICAL TO QUALITY CLASSIFICATION TABLE					
P=PERFORMANCE, F=FIT, A=ASSEMBLY					
X=IDENTIFIES APPLICABLE CLASSIFICATION(S)					
◇=ENGINEERING AND/OR MANUFACTURING REQUIREMENT					
Ⓜ=REGULATORY REQUIREMENT-CONFORMANCE IS MANDATORY					
COMMENTS	DRAWING ZONE	P	F	A	R
ROHS	G1-HI				X

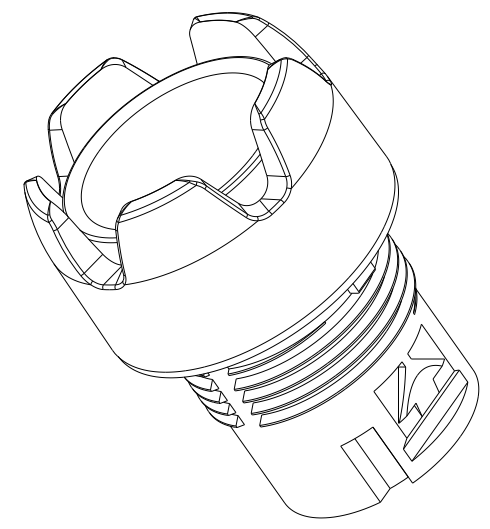

MUST COMPLY WITH ROCKWELL AUTOMATION ENVIRONMENTAL SPECIFICATION 970-20-01

ALL UNDIMENSIONED GEOMETRIES ARE CONTROLLED BY THE CAD MODEL. IN CASE OF DIMENSION DISCREPANCY, CAD MODEL OVERRIDES.

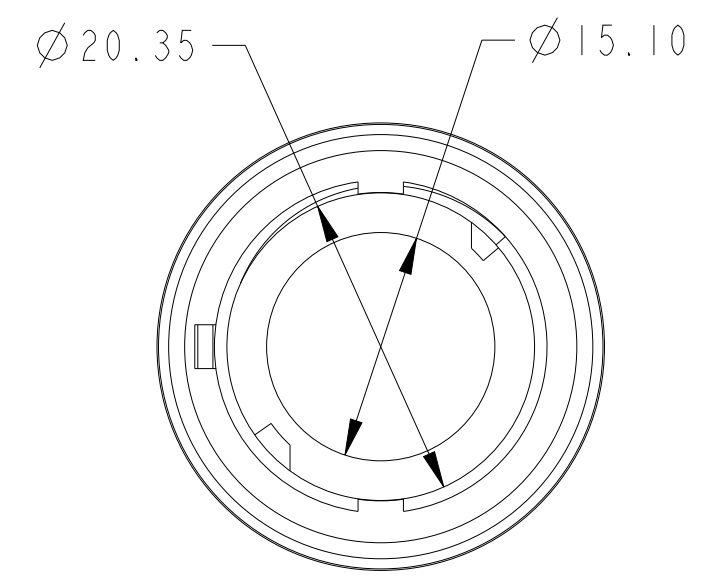
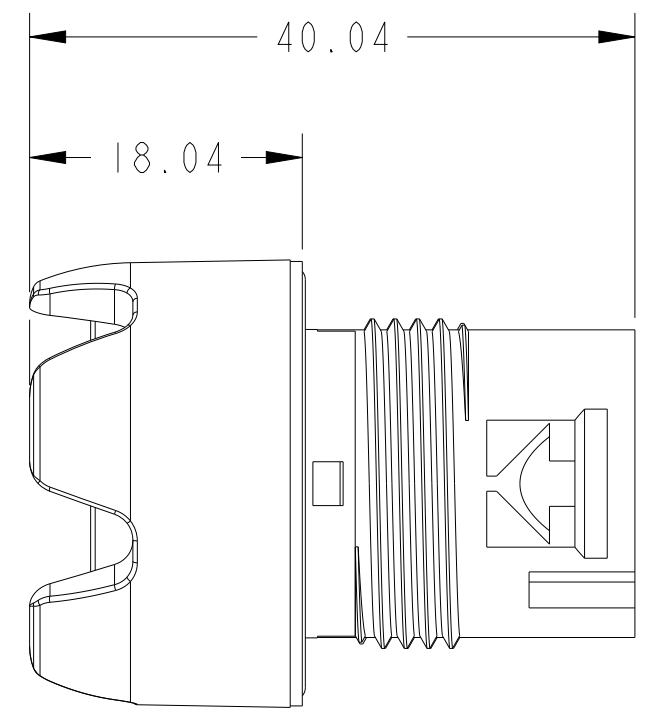
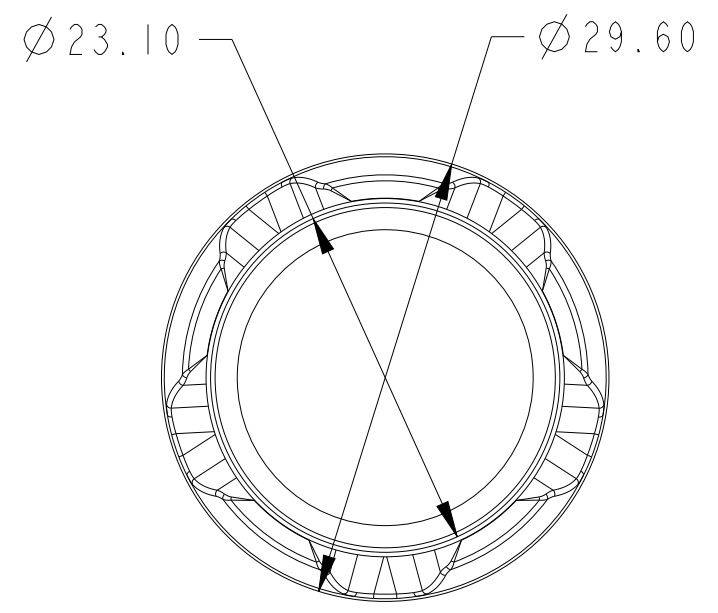

CONFIDENTIAL AND PROPRIETARY INFORMATION. THIS DOCUMENT CONTAINS CONFIDENTIAL AND PROPRIETARY INFORMATION OF ROCKWELL AUTOMATION, INC. AND MAY NOT BE USED, COPIED OR DISCLOSED TO OTHERS, EXCEPT WITH THE AUTHORIZED WRITTEN PERMISSION OF ROCKWELL AUTOMATION, INC.

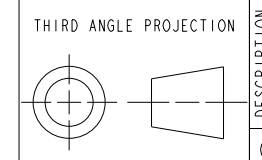

THIRD ANGLE PROJECTION

DESCRIPTION

800f_lg

CREATED BY: SSHARM35

CHANGED BY: *****

DATE: 2020-07-24

SHEET 1 OF 1

SIZE	DIR	VER
B	XXXX	01

