

CRITICAL TO QUALITY CLASSIFICATION TABLE				
P=PERFORMANCE, F=FIT, A=ASSEMBLY				
X=IDENTIFIES APPLICABLE CLASSIFICATION(S)				
◇=ENGINEERING AND/OR MANUFACTURING REQUIREMENT				
⊕=REGULATORY REQUIREMENT - CONFORMANCE IS MANDATORY				
COMMENTS	DRAWING (ZONE)	P	F	A
ROHS	H1			X

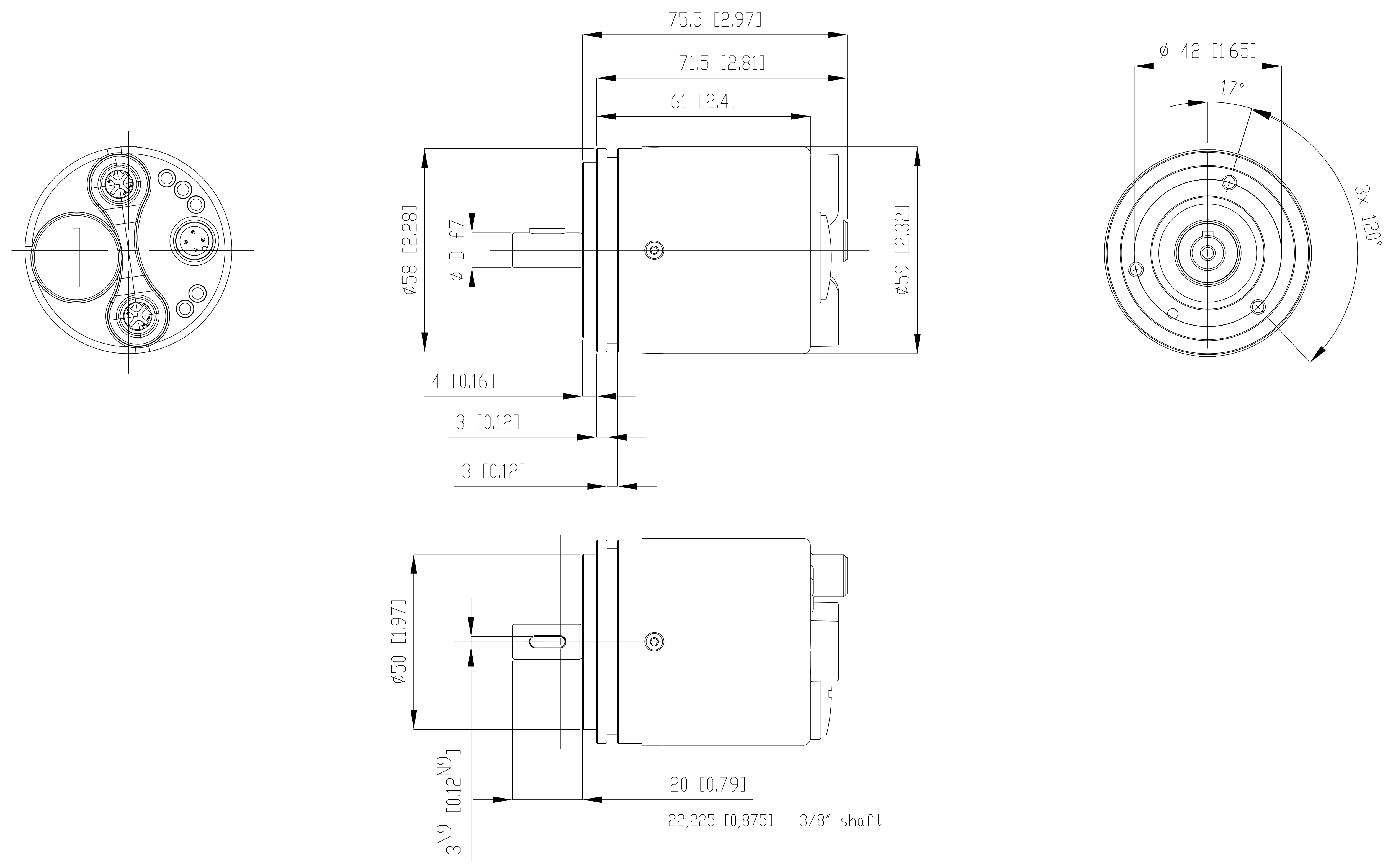

SYNCHRO FLANGE

- NOTES:
1. ALL DIMENSIONS IN MM (INCHES) AND ARE FOR REFERENCE ONLY.
 2. 10 MM, 12 MM AND 3/8 INCH SHAFT DIAMETERS ϕD .

		CONFIDENTIAL AND PROPRIETARY INFORMATION. THIS DOCUMENT CONTAINS CONFIDENTIAL AND PROPRIETARY INFORMATION OF ROCKWELL AUTOMATION, INC. AND MAY NOT BE USED, COPIED OR DISCLOSED TO OTHERS, EXCEPT WITH THE AUTHORIZED WRITTEN PERMISSION OF ROCKWELL AUTOMATION, INC.	
DESCRIPTION	DATE	2020-01-14	SHEET 1 OF 1
843ES CIP SAFETY ETHERNET IP, ENCODER	SIZE	D	DIR
CREATED BY NKUMAR23	CHANGED BY NKUMAR23	843ES-XIPXA4	

MUST COMPLY WITH ROCKWELL AUTOMATION ENVIRONMENTAL SPECIFICATION 97520-01