

- 1 OPENING OF FREEZE/FIRE INTERLOCK (IN DRIVE MODE) WILL REQUIRE MANUAL RESET.
- 2 "P1" DEFAULT POSITION IS PARKED IN POSITION "A". FOR PURGE WITH HAND-OFF-AUTO SWITCH IN OFF POSITION MOVE "P1" TO POSITION "B".
- 3 "P2" DEFAULT POSITION IS PARKED IN POSITION "A-B". FOR DRIVE TEST IN BYPASS MOVE "P2" TO POSITION "B-C".

DATE	BY	APPROVAL
		DESIGN REVIEW
		FOR MANUFACTURING
		AS SHIPPED
		AS COMMISSIONED

REV.	DATE	BY	ECN/CR. NO.
A	11/24/04	JRF	
B	5/18/05	JRF	
C	6/8/07	REH	
D	6/23/08	AVR	



THIS DRAWING IS THE PROPERTY OF ROCKWELL AUTOMATION, INC. OR ITS SUBSIDIARIES AND MAY NOT BE COPIED, USED OR DISCLOSED FOR ANY PURPOSE EXCEPT AS AUTHORIZED IN WRITING BY ROCKWELL AUTOMATION, INC.

TITLE
SCHEMATIC DRAWING - PF400, STYLE B, W/LINE REACTOR
3-50HP @ 208VAC & 3-100HP @ 460VAC

DR. BY JRF/ACI DATE 5/17/04	CHK. BY JFH/ACI DATE 5/17/04	ENG. DATE	DWG. NO. 98D00757 -	NEXT SH. 2	SH. NO. 1
--------------------------------	---------------------------------	-----------	---------------------	------------	-----------

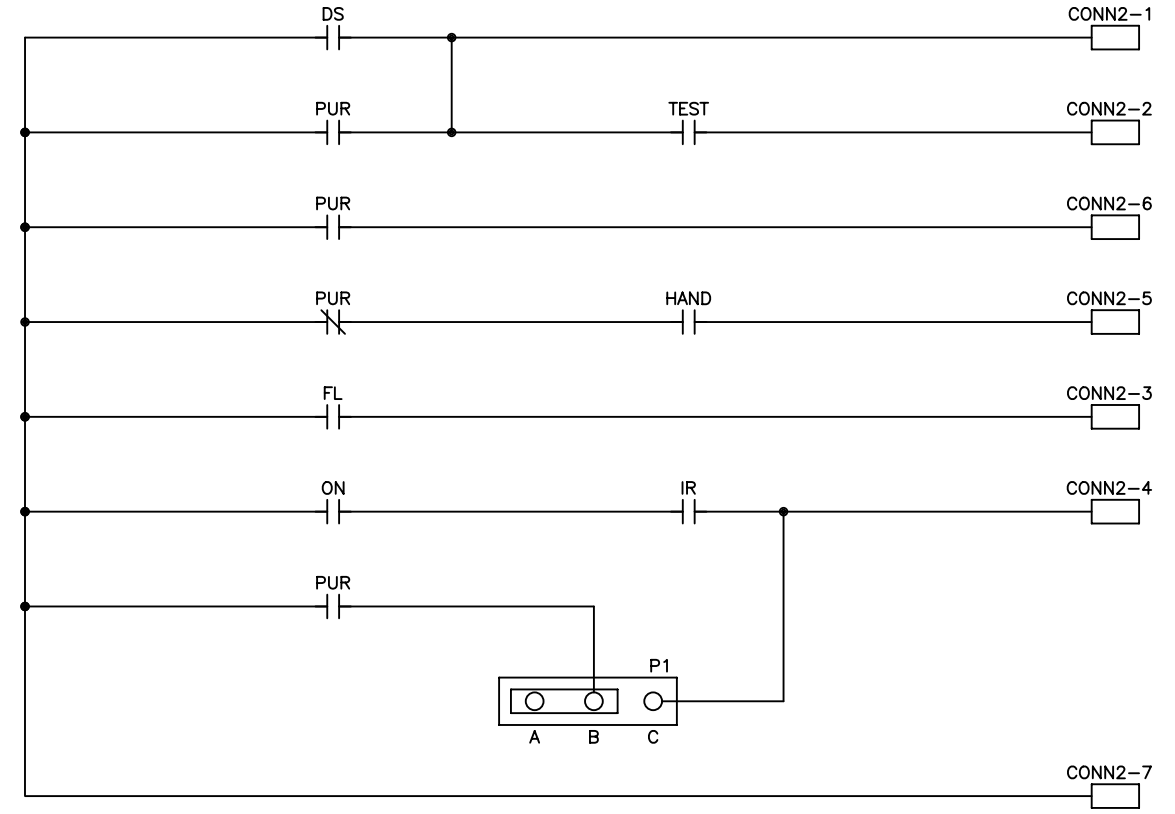
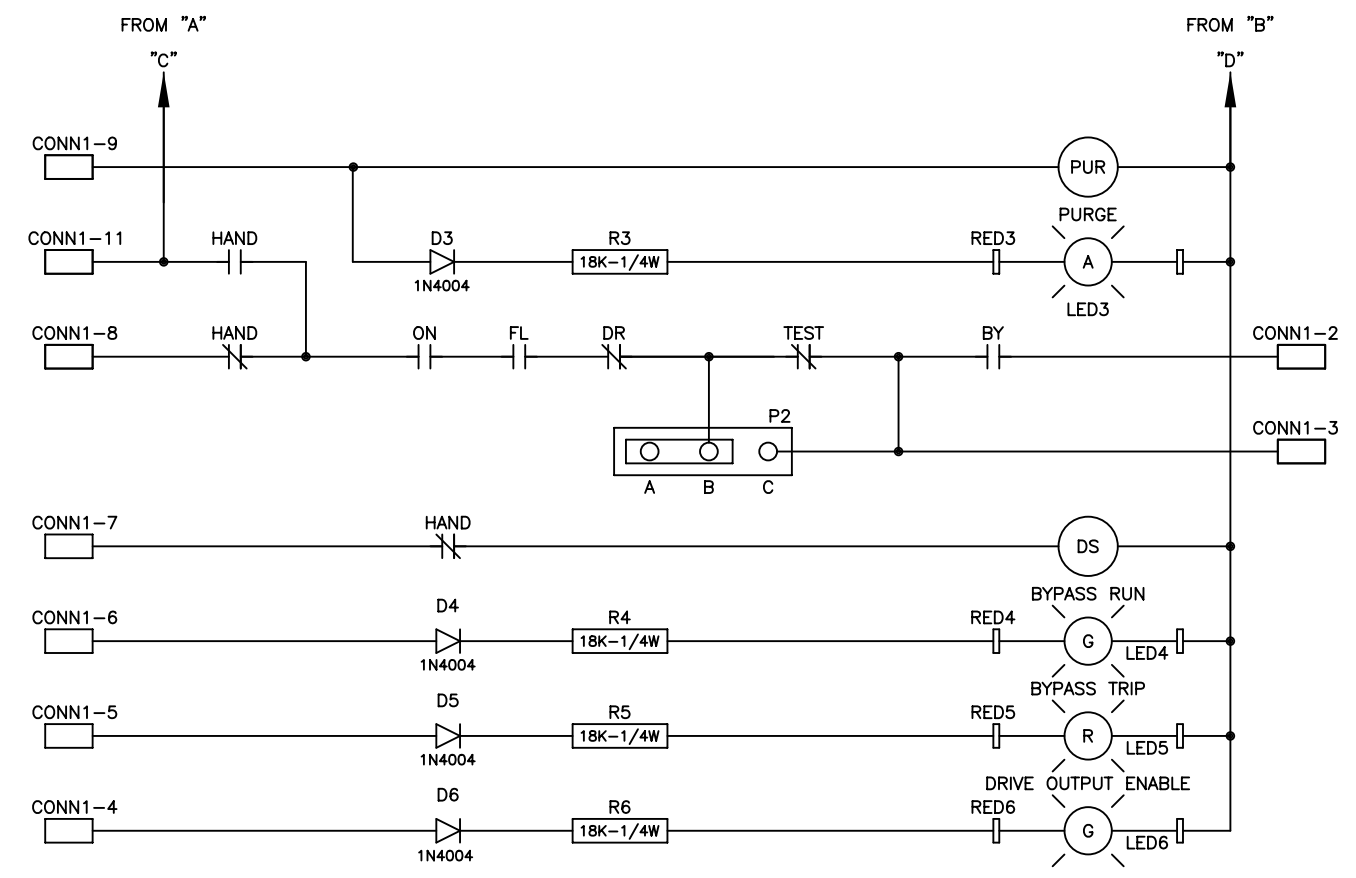
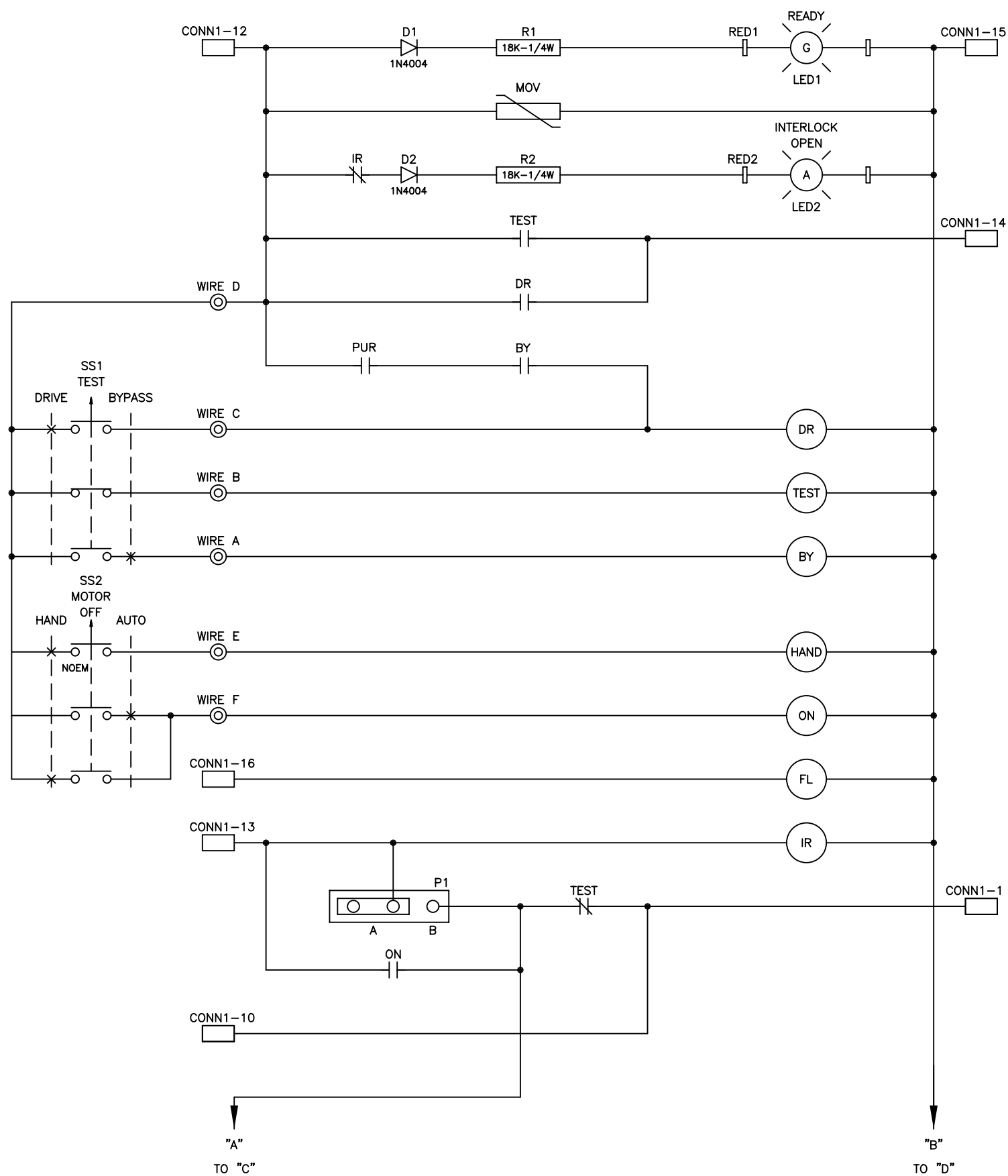

DATE	BY	APPROVAL
		DESIGN REVIEW
		FOR MANUFACTURING
		AS SHIPPED
		AS COMMISSIONED

REV.	DATE	BY	ECN/CR. NO.
A	11/24/04	JRF	
B	5/18/05	JRF	
C	6/8/07	REH	
D	6/25/08	AWR	



THIS DRAWING IS THE PROPERTY OF ROCKWELL AUTOMATION, INC. OR ITS SUBSIDIARIES AND MAY NOT BE COPIED, USED OR DISCLOSED FOR ANY PURPOSE EXCEPT AS AUTHORIZED IN WRITING BY ROCKWELL AUTOMATION, INC.

TITLE
SCHEMATIC DRAWING - PF400, STYLE B, W/LINE REACTOR
3-50HP @ 208VAC & 3-100HP @ 460VAC

DR. BY JRF/ACI DATE 5/17/04	CHK. BY JFH/ACI DATE 5/17/04	ENG. DATE	DWG. NO. 98D00757 -	NEXT SH. 2	SH. NO. 2
--------------------------------	---------------------------------	-----------	---------------------	------------	-----------