

VIEW Y-Y

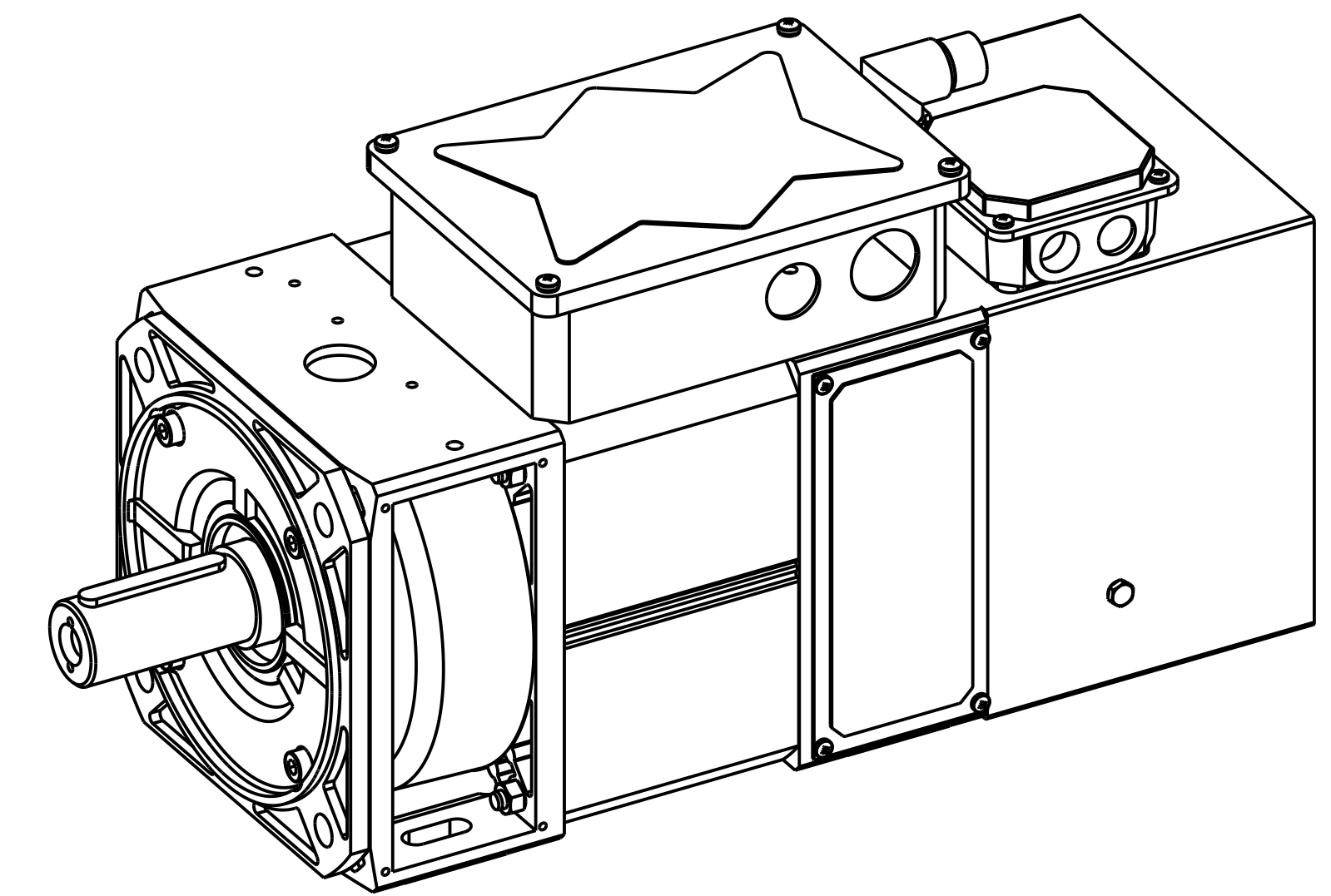
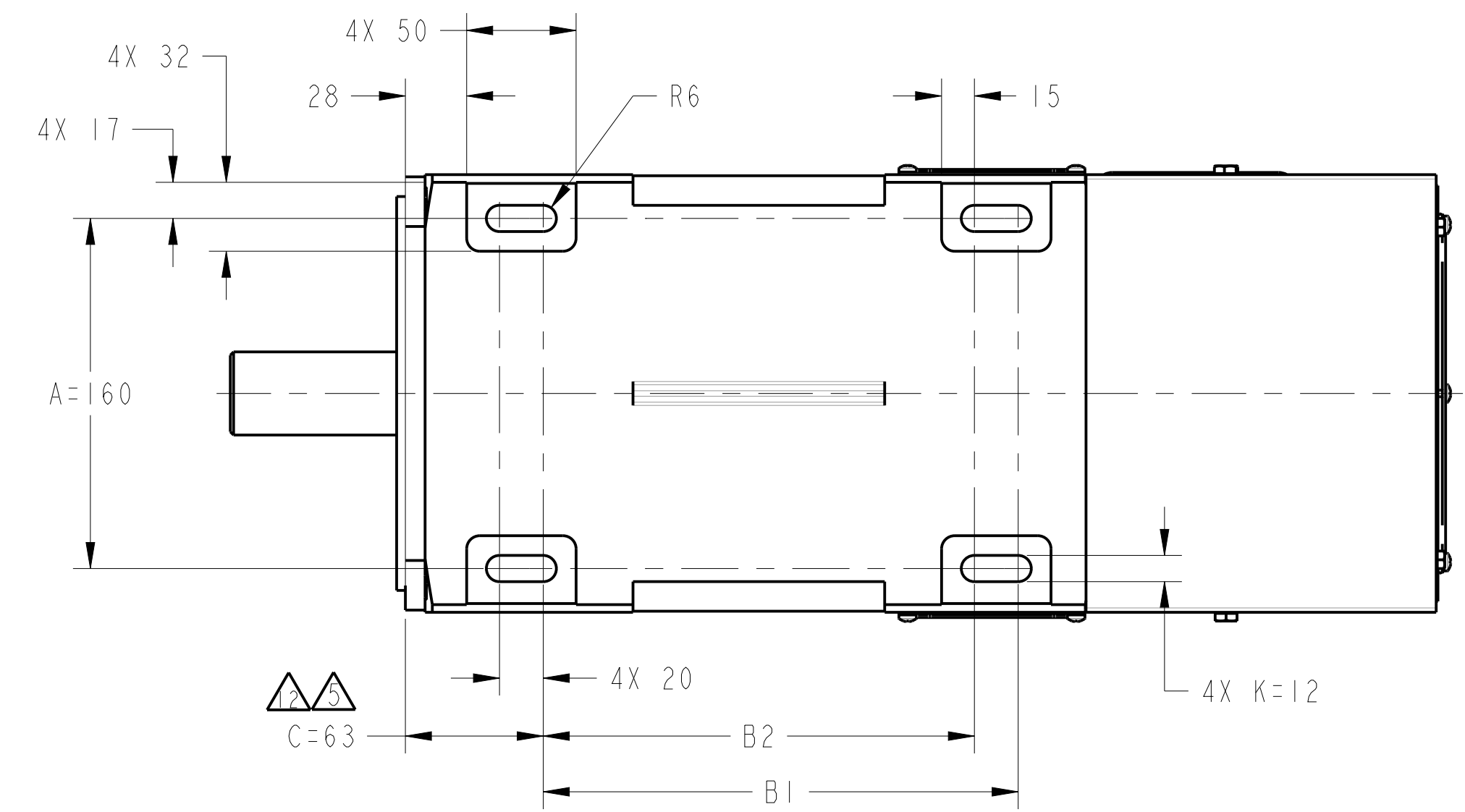
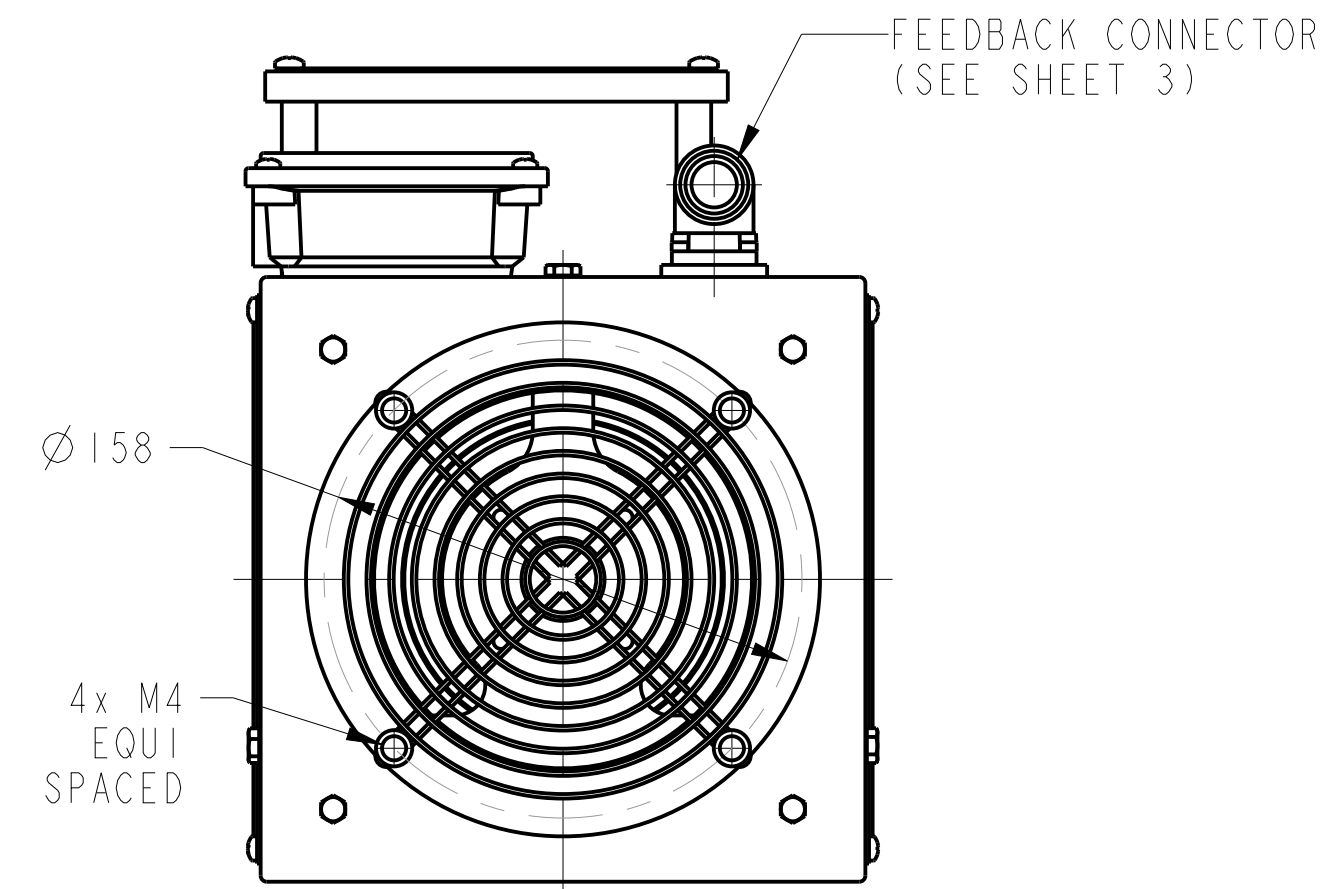
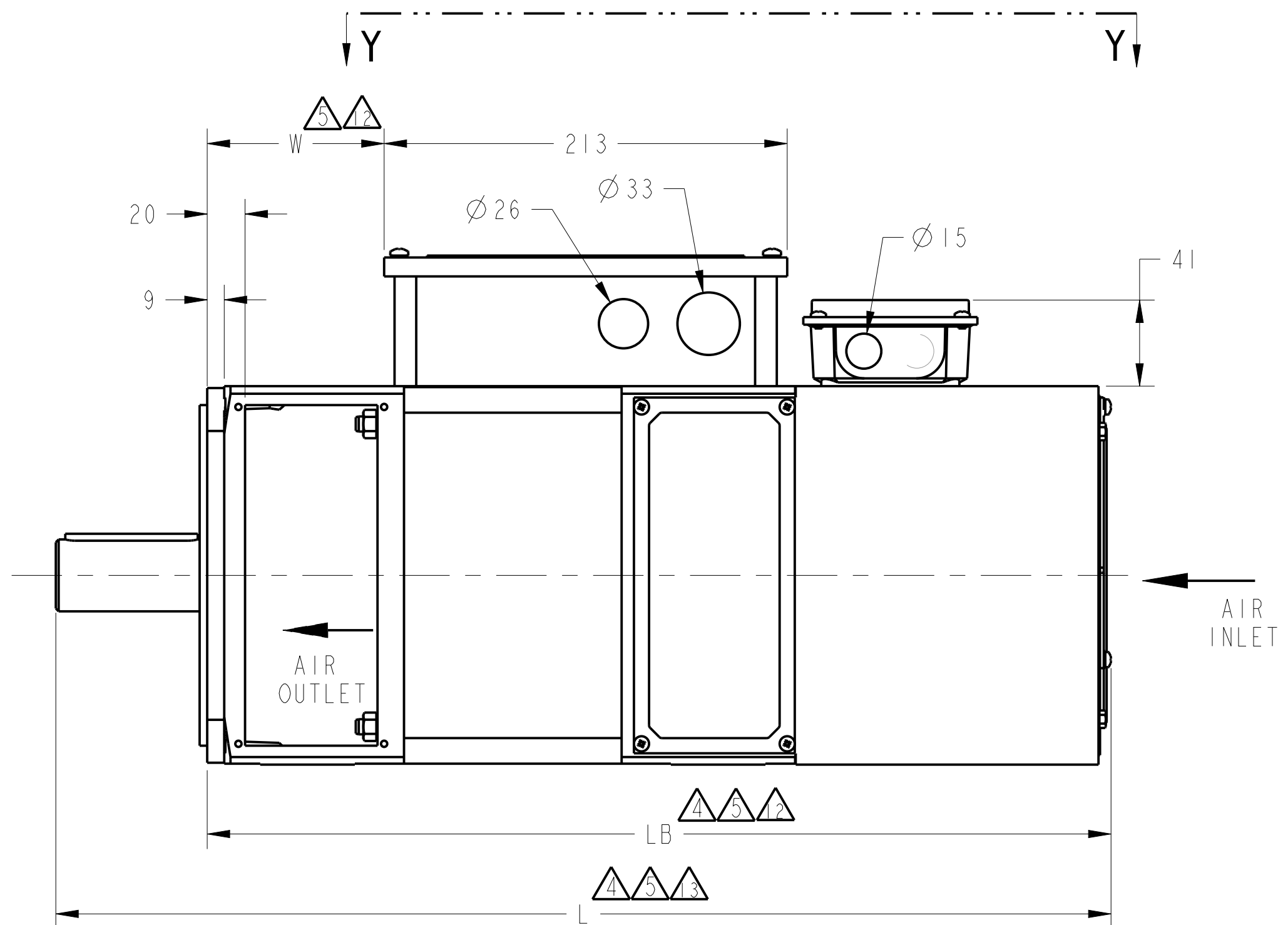

- NOTES:
1. ALL DIMENSIONS ARE IN MM AND DIMENSIONS WITHOUT TOLERANCES ARE REFERENCE.
 2. FOR ADDITIONAL SPECIFICATIONS SEE ESE DRAWING DIR 10006268890.
 3. DO NOT SCALE THE DRAWING.
 4. FOR ALL MOTORS EXCEPT THOSE WITH NO HOLDING BRAKE, CATALOG OPTION (MMA-B100XXX-XXXX22XXXXXX) ADD 80MM TO DIMENSION L & LB.
 5. REFER SHEET 2 FOR ADDITIONAL DIMENSIONS TABULATION.
 6. DEPENDING ON TERMINAL BOX OPTION SELECTED, POSITION OF THE TERMINAL BOXES AND DIRECTION OF CABLE GLAND WILL BE CHANGED.
 7. REFER SHEET 3 FOR TERMINAL BOX CONNECTONS AND CONNECTOR PIN DETAILS.

CATALOG (TRUNCATED)	B2	B1	L	LB	W
MMA-B100AXX	197	217	560	480	93
MMA-B100BXX	237	257	600	520	133
MMA-B100CXX	267	287	630	550	163
MMA-B100DXX	307	327	670	590	203
MMA-B100EXX	362	382	725	645	258

MUST COMPLY WITH ROCKWELL AUTOMATION ENVIRONMENTAL SPECIFICATION 970-20-01

ALL UNDIMENSIONED GEOMETRIES ARE CONTROLLED BY THE CAD MODEL. IN CASE OF DIMENSION DISCREPANCY, CAD MODEL OVERRIDES.

THIRD ANGLE PROJECTION

DESCRIPTION: DRW,MMA-B100X,KINETIX MOTOR,ESM

DATE: 2021-08-03 SHEET 1 OF 3

SIZE: D

VER: 00

10006066535

CREATED BY: MGHANDHI CHANGED BY: -

CONFIDENTIAL AND PROPRIETARY INFORMATION. THIS DOCUMENT CONTAINS CONFIDENTIAL AND PROPRIETARY INFORMATION OF ROCKWELL AUTOMATION, INC. AND MAY NOT BE USED, COPIED OR DISCLOSED TO OTHERS, EXCEPT WITH THE AUTHORIZED WRITTEN PERMISSION OF ROCKWELL AUTOMATION, INC.

MOTOR FLANGE DIMENSIONS

MOTOR CATALOG (TRUNCATED)	FLANGE OPTIONS SELECTION CODES	BOLT CIRCLE DIAMETER M	MTG HOLE DIAMETER S	PILOT DIAMETER N	PILOT THICKNESS T	FLANGE WIDTH SQUARE AC	MAX FLANGE OUTER DIAMETER P
MMA-B0100AXX-XXXXXXX	A,B,C,D	215	14.5	180 ^{+0.014} -0.011	4	198	250
MMA-B0100BXX-XXXXXXX							
MMA-B0100CXX-XXXXXXX							
MMA-B0100DXX-XXXXXXX							
MMA-B0100EXX-XXXXXXX	E,F,G	265	14.5	230 ^{+0.016} -0.013	4	250	300

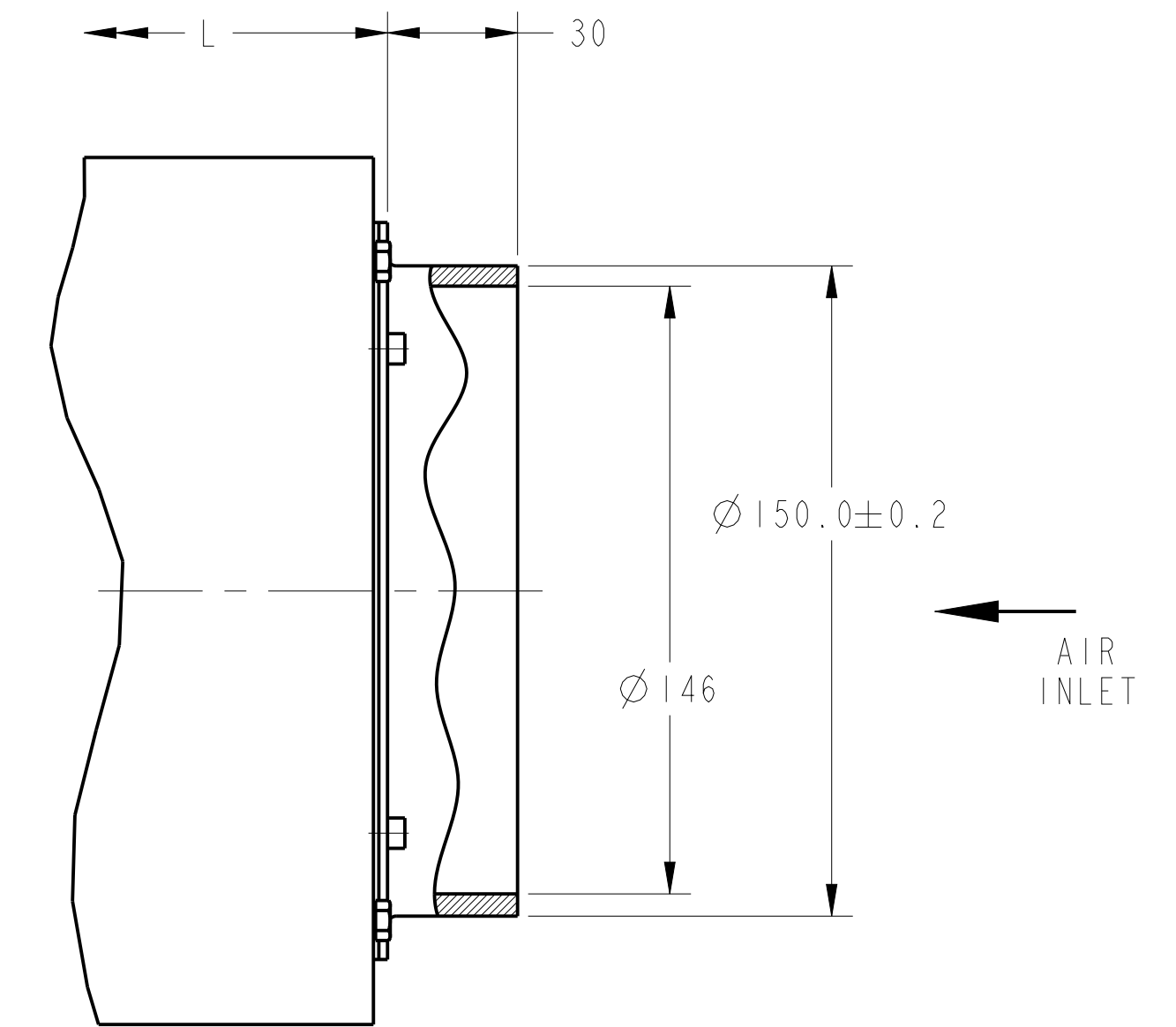
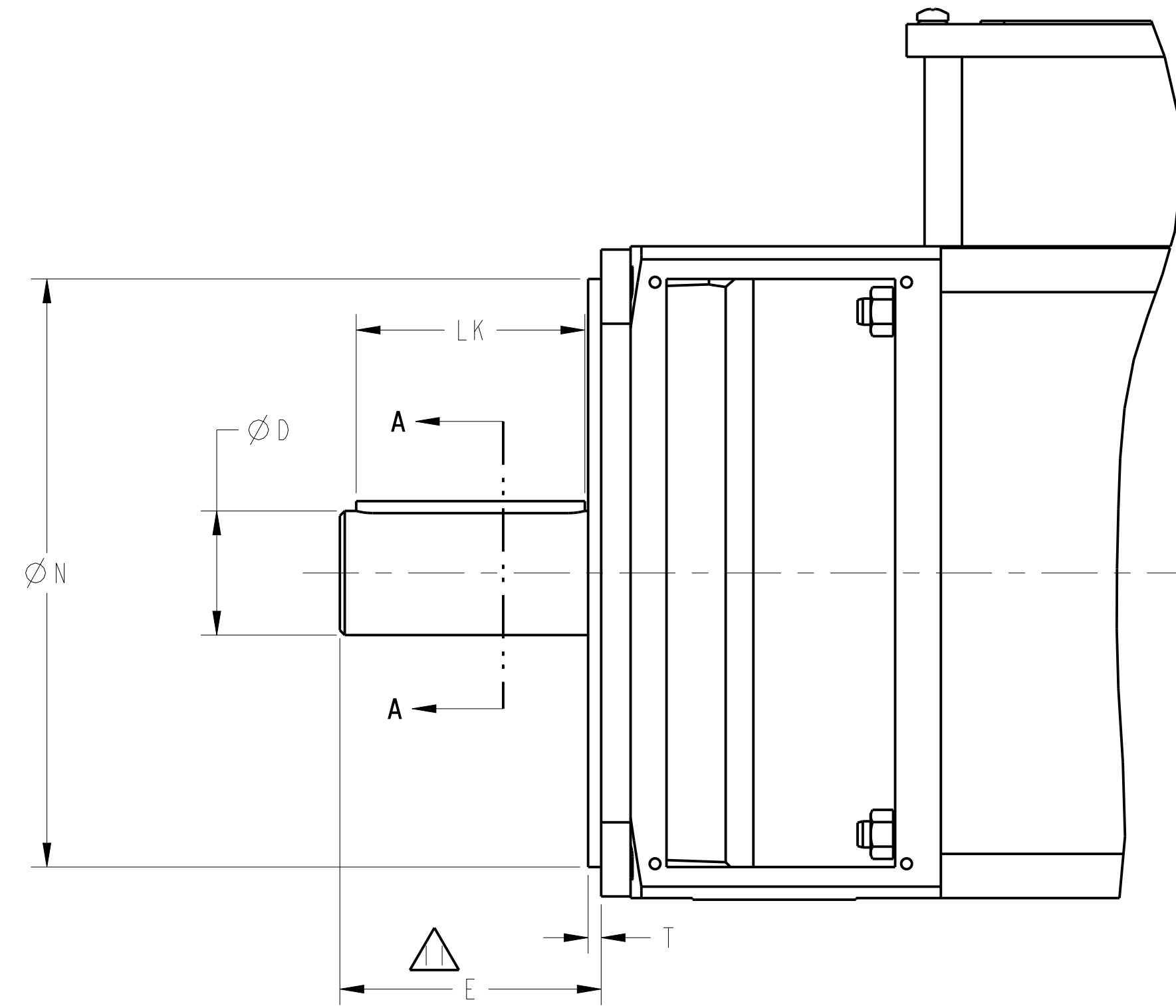
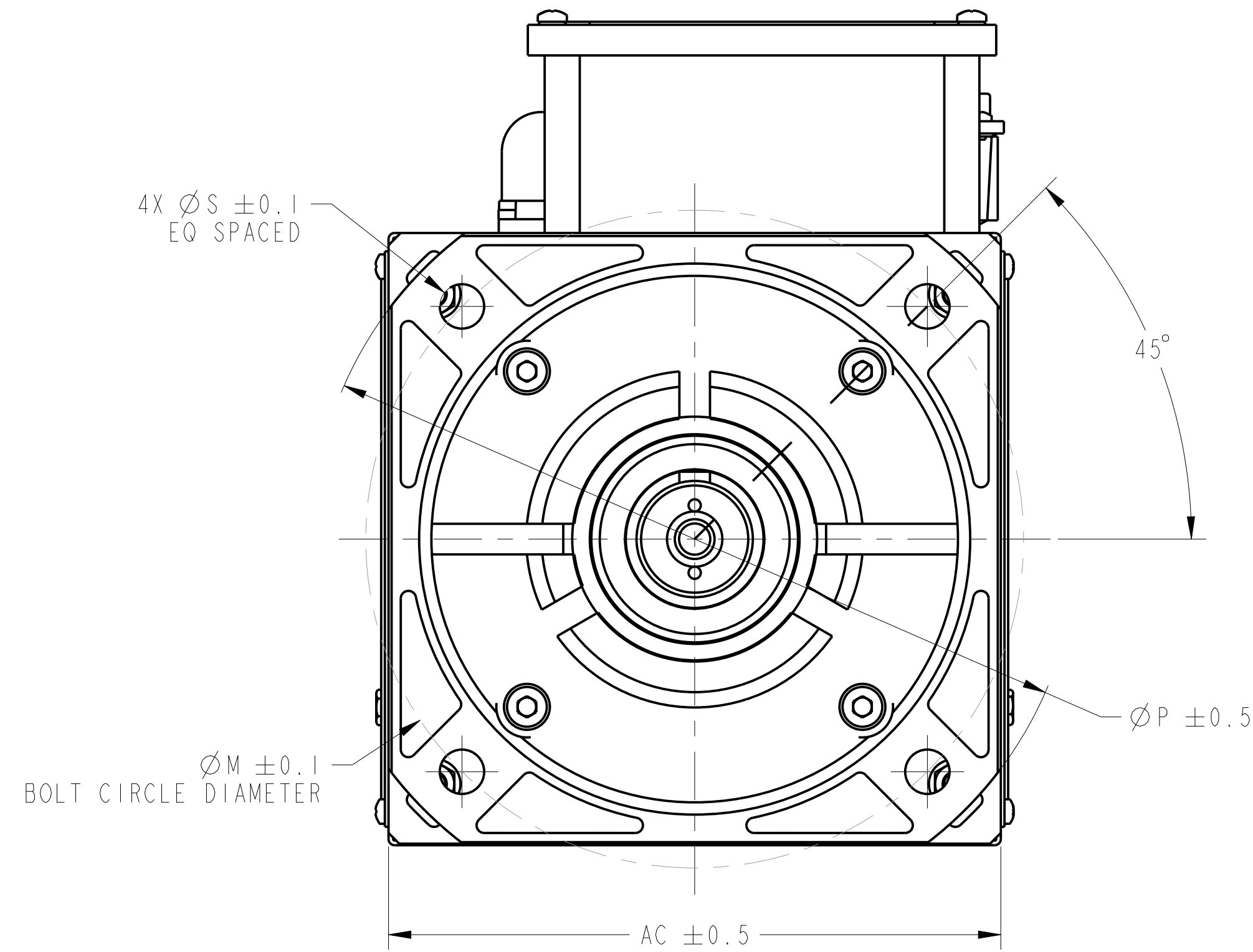

DIMENSIONS FOR IC17 COOLING OPTION
MMA-B100XXX-XXXXXXDXXXXXX

SHAFT AND KEY DIMENSIONS

MOTOR CATALOG (TRUNCATED)	SHAFT OPTIONS SELECTION CODES	KEY WIDTH F	SHAFT WIDTH OVER KEY GA	DEPTH OF KEYWAY GE	KEY LENGTH LK	DIAMETER D	SHAFT LENGTH E	THREAD SIZE TS
MMA-B0100AXX-XX	A,B,C,D	10	41	5	70	38 ^{+0.018} +0.002	80	M12
MMA-B0100BXX-XX								
MMA-B0100CXX-XX								
MMA-B0100DXX-XX								
MMA-B0100EXX-XX	E,F	NA	NA	NA	NA			
MMA-B0100AXX-XX	N,P,Q,R	8	31	4	50	28 ^{+0.009} -0.004	60	M10
	S,T	NA	NA	NA	NA			

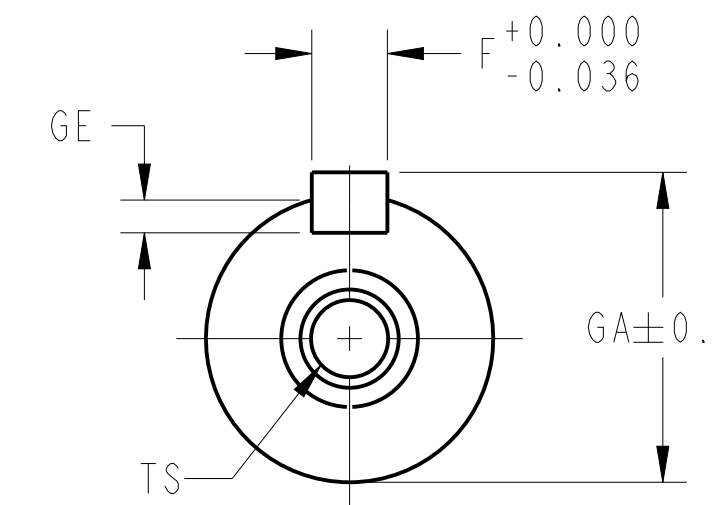

SECTION A-A

NOTES:

- 1. WHEN INCREASED DIMENSION FLANGE OPTION SELECTED (FLANGE CODES: E,F,G), LENGTH OF THE SHAFT WILL REDUCE BY 10 MM.
- 2. WHEN INCREASED FLANGE OPTION SELECTED (FLANGE CODES: E,F,G) DIMENSION "LB", "C" AND "W" WILL INCREASE BY 10 MM.
- 3. WHEN REDUCED SHAFT OPTION SELECTED (SHAFT CODES: N,P,Q,R,S,T) LENGTH "L" IS REDUCED BY 10 MM.

		<small>CONFIDENTIAL AND PROPRIETARY INFORMATION. THIS DOCUMENT CONTAINS CONFIDENTIAL AND PROPRIETARY INFORMATION OF ROCKWELL AUTOMATION, INC. AND MAY NOT BE USED, COPIED OR DISCLOSED TO OTHERS, EXCEPT WITH THE AUTHORIZED WRITTEN PERMISSION OF ROCKWELL AUTOMATION, INC.</small>	
		DATE: 2021-08-03	SHEET 2 OF 3
DESCRIPTION: DRW,MMA-B100X,KINETIX MOTOR,ESM	SIZE: D1R	D	VER: 00
CREATED BY: MGHANDI	CHANGED BY: -	10006066535	

MOTOR TERMINAL BOX

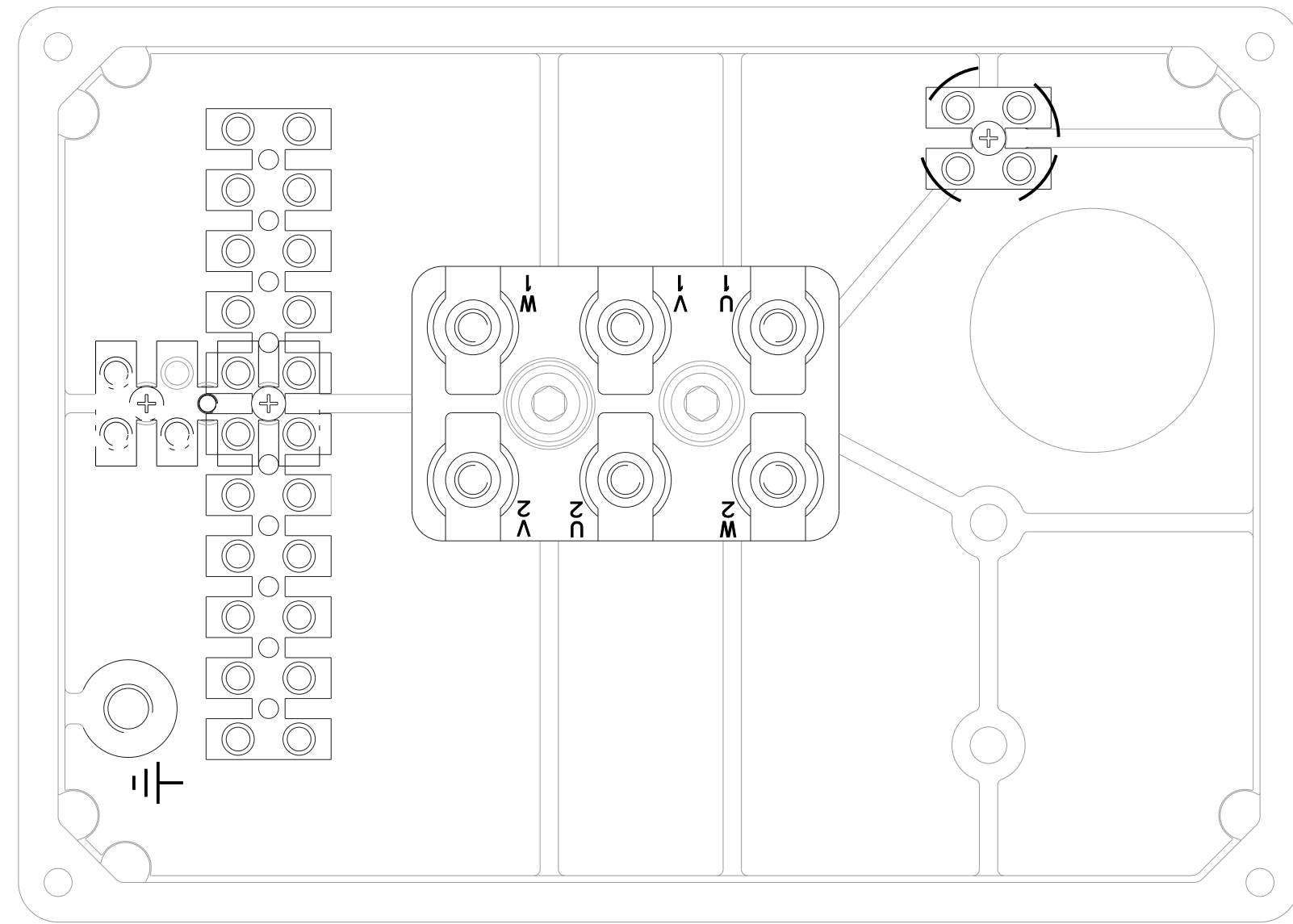

BLOWER TERMINAL BOX

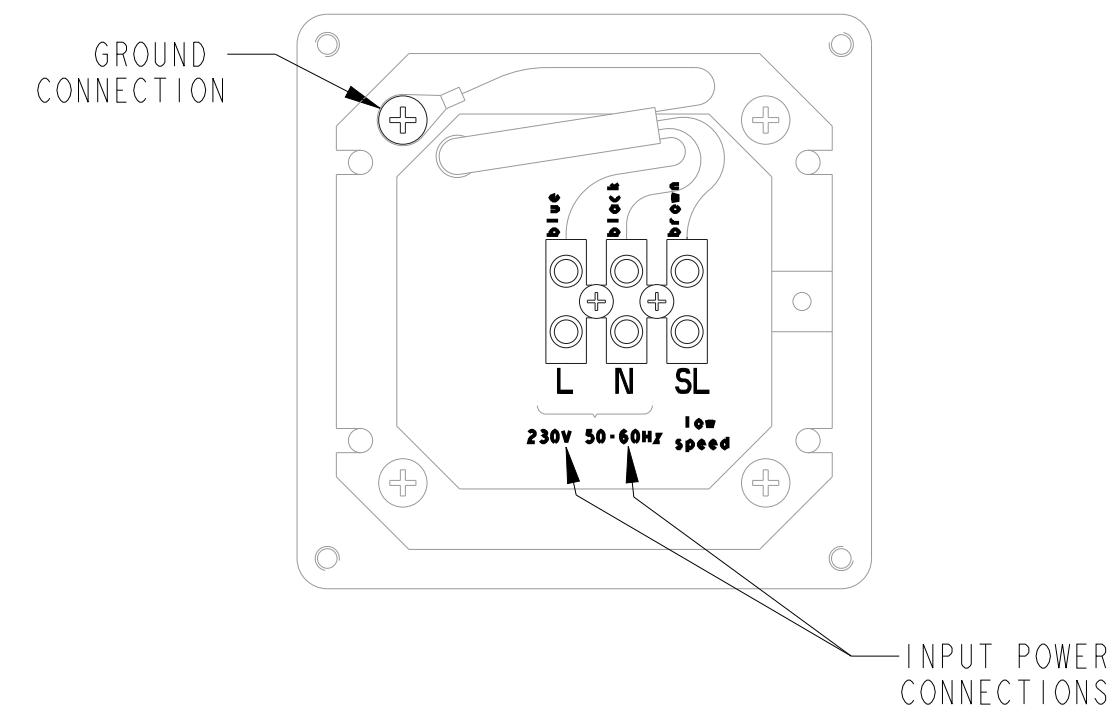

FEEDBACK CONNECTOR

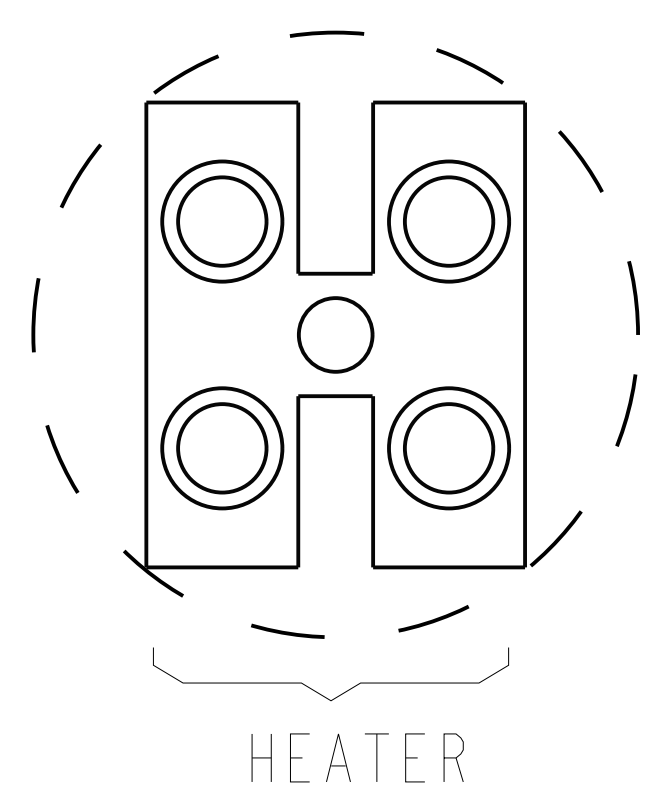
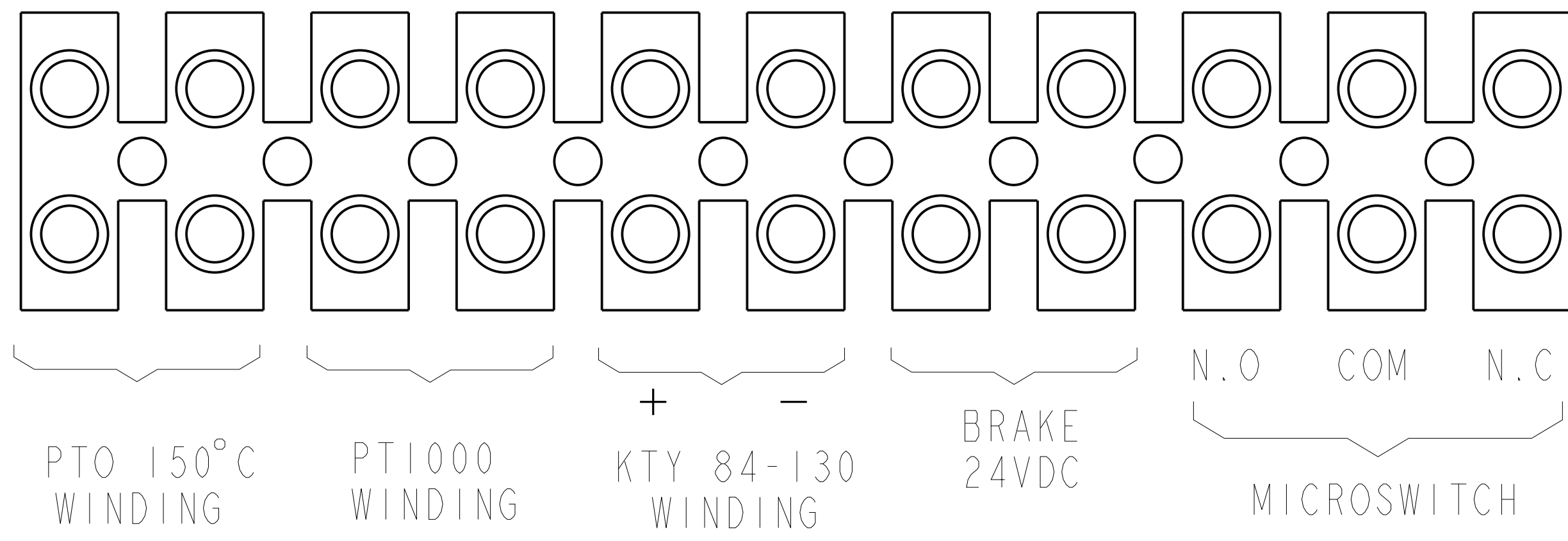
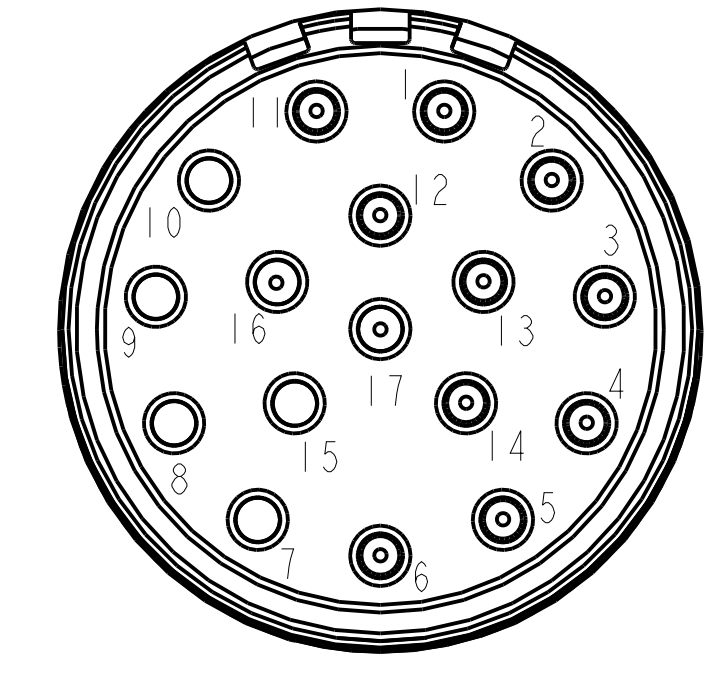

NOTES:
21 DEPENDING ON THE MOTOR CONFIGURATION OPTIONS, THE TERMINALS POSITION MAY BE CHANGED OR ELIMINATED

FEEDBACK CONNECTOR	RA CATALOG - ENCODER DESIGNATION			
	L2	S1, S2, M1, M2	S3, M3	S4, M4,
CONTACT NUMBER	VFx60	SF x60 MOTOR, SF x60 SAFETY	ECN413, EON425	ECN425, EON437
1	A+	SIN+	SIN+	-
2	A-	SIN-	SIN-	-
3	B+	COS+	COS+	-
4	B-	COS-	COS-	-
5	IM+	DATA+	DATA+	DATA+
6	IM-	DATA-	DATA-	DATA-
7	-	-	CLK+	CLK+
8	-	-	CLK-	CLK-
9	-	-	-	-
10	-	-	-	-
11	EPWR 9V	EPWR 9V	EPWR 9V	EPWR 9V
12	ECOM	ECOM	ECOM	ECOM
13	TS+	TS+	TS+	TS+
14	TS-	TS-	TS-	TS-
15	-	-	-	-
16	PT1	PT1	PT1	PT1
17	PT2	PT2	PT2	PT2

		<small>CONFIDENTIAL AND PROPRIETARY INFORMATION. THIS DOCUMENT CONTAINS CONFIDENTIAL AND PROPRIETARY INFORMATION OF ROCKWELL AUTOMATION, INC. AND MAY NOT BE USED, COPIED OR DISCLOSED TO OTHERS, EXCEPT WITH THE AUTHORIZED WRITTEN PERMISSION OF ROCKWELL AUTOMATION, INC.</small>	
		DESCRIPTION DRW, MMA-BIOOX, KINETIX MOTOR, ESM	DATE: 2021-08-03 SIZE: D1R
CREATED BY: MGANDHI	CHANGED BY: -	10006066535	00