

# **RDD-Series Rotary Direct Drive Bearingless Motors**

Catalog Numbers RDB-B2901, RDB-B2902, RDB-B2903, RDB-B4101, RDB-B4102, RDB-B4103

<b>Topic</b>	<b>Page</b>
Important User Information	2
Catalog Number Explanation	3
Before You Begin	4
Install the Motor	9
Remove the Motor	19
Connector Data	26
Product Dimensions	27
Specifications	30
Additional Resources	31

## **About the Direct Drive Bearingless Motors**

RDD-Series direct drive motors feature single-turn or multi-turn high resolution encoders. These bearingless housed motors provide a compact design for direct drive applications.

## Important User Information

Solid state equipment has operational characteristics differing from those of electromechanical equipment. Safety Guidelines for the Application, Installation and Maintenance of Solid State Controls, publication [SGL-1.1](#), is available from your local Rockwell Automation sales office or online at <http://literature.rockwellautomation.com> describes some important differences between solid state equipment and hard-wired electromechanical devices. Because of this difference, and also because of the wide variety of uses for solid state equipment, all persons responsible for applying this equipment must satisfy themselves that each intended application of this equipment is acceptable.





In no event will Rockwell Automation, Inc. be responsible or liable for indirect or consequential damages resulting from the use or application of this equipment.

The examples and diagrams in this manual are included solely for illustrative purposes. Because of the many variables and requirements associated with any particular installation, Rockwell Automation, Inc. cannot assume responsibility or liability for actual use based on the examples and diagrams.

No patent liability is assumed by Rockwell Automation, Inc. with respect to use of information, circuits, equipment, or software described in this manual.

Reproduction of the contents of this manual, in whole or in part, without written permission of Rockwell Automation, Inc., is prohibited.

Throughout this manual, when necessary, we use notes to make you aware of safety considerations.

<p><b>WARNING</b></p> 	<p>Identifies information about practices or circumstances that can cause an explosion in a hazardous environment, which may lead to personal injury or death, property damage, or economic loss.</p>
<p><b>IMPORTANT</b></p>	<p>Identifies information that is critical for successful application and understanding of the product.</p>
<p><b>ATTENTION</b></p> 	<p>Identifies information about practices or circumstances that can lead to personal injury or death, property damage, or economic loss. Attentions help you identify a hazard, avoid a hazard and recognize the consequences.</p>
<p><b>SHOCK HAZARD</b></p> 	<p>Labels may be on or inside the equipment, for example, a drive or motor, to alert people that dangerous voltage may be present.</p>
<p><b>BURN HAZARD</b></p> 	<p>Labels may be on or inside the equipment, for example, a drive or motor, to alert people that surfaces may reach dangerous temperatures.</p>

## Catalog Number Explanation

**R DB - B 410 3 F - 7 B 7 2 AA**

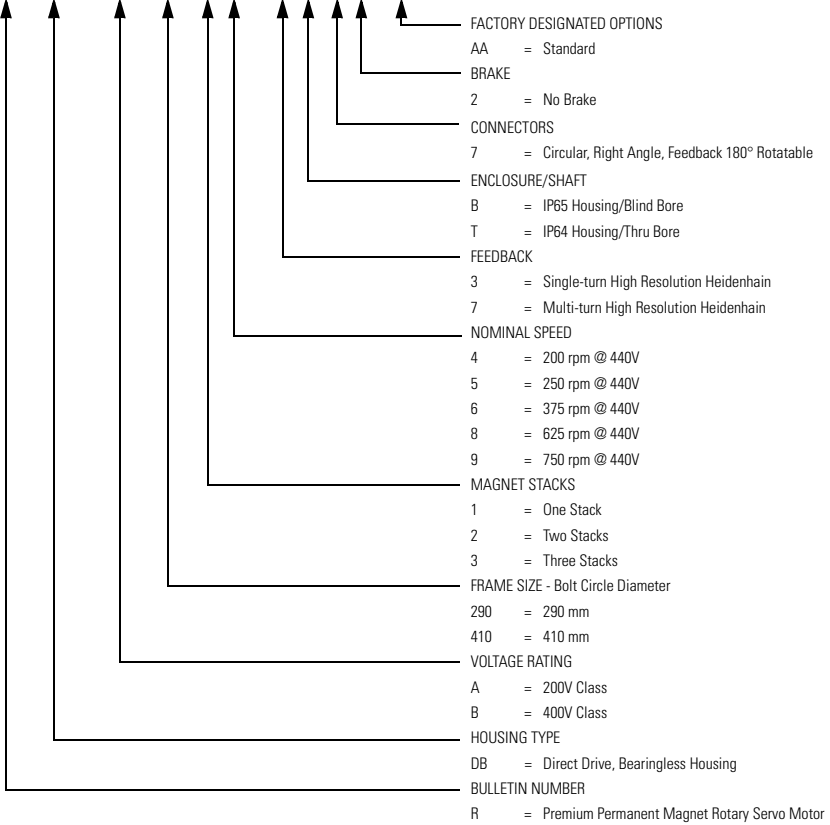

### Before You Begin

Remove all packing material, wedges, and braces from within and around the item. After unpacking, verify the nameplate catalog number against the purchase order.

1. Remove the motor carefully from its shipping container.
2. Visually inspect the motor, mounting pilot, and encoder for damage.
3. Notify the carrier of any shipping damage immediately.
4. Retain the cardboard cover and protective paper sleeving from the mounting end of the motor.

---

**ATTENTION**

The mounting end of the motor exposes magnetized material within the motor. Accidental entry of foreign material will harm motor performance.

Always cover the mounting end of motor immediately after removing the motor. This will greatly reduce magnetic or non-magnetic particles from accidentally entering the motor.

---

## Required Tools

These tools are needed to install this product.

<b>Tools Required for Installation</b>	<b>Value</b>
Hex bit, 150 mm (6 in.) minimum length	6 mm
Torque wrench	Capable of applying at least 65 N•m (50 lb•ft)
Screwdriver	Phillips #2
Micrometer	N/A
Straight edge	
Caliper	
Runout indicator	
Cleaning cloth	
Shaft key (provided)	

These additional tools are needed when removing this product.

<b>Additional Tools Required for Removal</b>	<b>Value</b>
M6 x 1 x 120 hex bolt or rod (For RDB-B4103 motor only)	Qty 1
M10 and M12 hex bolts	Qty 2 min
Flashlight	N/A
Hammer	

## Prolonging Motor Life

Thoughtful design and proper maintenance can increase the life of this motor. Follow these guidelines to maximize the life of the motor:

- Always provide a drip loop in each cable to carry liquids away from the connection to the motor.
- If design requirements permit, provide shields that protect the motor housing, shaft, seals, and their junctions from contamination by foreign matter or fluids.
- Inspect the motor for damage or wear on a regular basis. If damage or excessive wear is observed, replace the item.

## Preventing Electrical Noise

ElectroMagnetic Interference (EMI), commonly called electrical noise, can reduce motor performance. Effective techniques to counter EMI include filtering the AC power, using shielded cables, separating signal cables from power wiring, and practicing good grounding techniques.

Follow these guidelines to avoid the effects of EMI:

- Isolate the power transformers or install line filters on all AC input power lines.
- Physically separate signal cables from motor cabling and power wiring. Do not route signal cables with motor and power wires, or over the vent openings of servo drives.
- Ground all equipment by using a single-point parallel ground system that employs ground bus bars or large straps. If necessary, use additional electrical noise reduction techniques to reduce EMI in noisy environments.

Refer to the System Design for Control of Electrical Noise Reference Manual, publication [GMC-RM001](#), for additional information on reducing the effects of EMI.

## Build and Route Cables

Knowledgeable cable routing and careful cable construction improves system performance.

Follow these guidelines to build and install cables:

- Keep wire lengths as short as physically possible.
- Route noise sensitive wiring (encoder, serial, I/O) away from input power and motor power wiring.
- Separate cables by 0.3 m (1 ft) minimum for every 9 m (30 ft) of parallel run.
- Ground both ends of the encoder cable shield and twist the signal wire pairs to prevent electromagnetic interference (EMI) from other equipment.

---

**WARNING**

Do not tightly gather or coil the excess length of a power cable. Heat is generated within a cable whenever power is applied. Always position a power cable so it may freely dissipate any heat.

A power cable should not be coiled, except for temporary use when building or testing a machine. If you temporarily coil a power cable, you must also derate the cable to meet local code or follow an authoritative directive, such as Engineering Section 310.15(C) of the NEC Handbook.

Failure to observe these safety procedures could result in personal injury or equipment damage.

---

## Ground the Shielded Signal Wires within a Power Cable

Always ground the shield on any signal wires inside a power cable. Connecting this shield to chassis ground reduces the potential for voltage inductance and EMI.

### SHOCK HAZARD



If any shield on a power cable is not grounded, high voltage can be present on that shield.

Make sure there is a connection to ground for all shield wires inside a power cable, and for the overall power cable shield.

Failure to observe safety precautions could result in personal injury or damage to equipment.

To ground the shield wire on a 2090-CPBM7DF-xxAFxx or 2090-XXNPMF-xxSxx power cable:

1. Loop the signal wire pair to the overall cable shield as shown in the diagram.
  - Cable 2090-CPBM7DF-xxAFxx (shown) contains one signal wire pair.
  - Cable 2090-XXNPMF-xxSxx contains two signal wire pairs.
2. Clamp all signal wire shields and the overall power-cable shield in the power cable (chassis) ground clamp on the drive.

## Grounding of Signal Wire Shields in a Power Cable

Factory Supplied

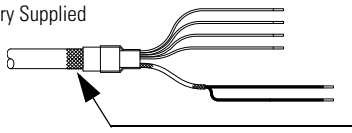

Shielded Signal Wires (one pair shown) within Power Cable

Overall Power Cable Shield

Field Modified

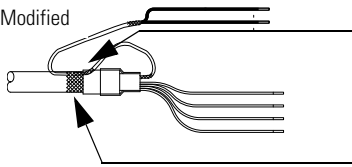

Signal Wire Shield Contacts Overall Power Cable Shield

All power and signal wire shields must connect to machine ground.



## Install the Motor

All motors include a mounting pilot for aligning the motor on the machine. Preferred fasteners are hardened steel. The installation must comply with all local regulations and use equipment and installation practices that promote safety and electromagnetic compatibility.

---

**ATTENTION**

Unmounted motors, disconnected mechanical couplings, loose shaft keys, and disconnected cables are dangerous if power is applied.

Disassembled equipment should be appropriately identified (tagged-out) and access to electrical power restricted (locked-out).

Before applying power to the motor, remove the shaft key and other mechanical couplings that could be thrown from the shaft.

Failure to observe these safety precautions could result in personal injury.

---

**ATTENTION**

Servo drive power must be turned off before connecting or disconnecting the cables to the motor, and if a cable is left disconnected at the motor end.

Arcing or unexpected motion could occur if the feedback, power, or brake cables are connected or disconnected while power is applied to the servo drive.

Failure to observe these safety procedures could result in personal injury or damage to the motor and equipment.

---

**ATTENTION**

Do not attempt to open or modify this motor.

Only an authorized Allen-Bradley repair center shall service this item. Refer to Rockwell Automation Support for assistance to locate the nearest repair center.

Failure to observe safety precautions could result in personal injury or damage to equipment.

---

## Preparing the Motor for Installation

Follow these steps to prepare a motor for installation.

1. Verify sufficient clearance, heatsink mass, and air flow for the motor so it stays within the operating temperature range of 0...40 °C (32...104 °F).

Do not enclose the motor unless cooling air is forced across the motor, and keep other heat producing devices away from the motor. Heatsink requirements are listed in a footnote to the [Specifications](#) table.

---

### **BURN HAZARD**



Outer surfaces of a motor can reach high temperatures, 125 °C (275 °F), during operation.

Take precautions to prevent accidental contact with hot surfaces. Consider motor surface temperature when selecting connections and cables to install on a motor.

Failure to observe safety precautions could result in personal injury or damage to equipment.

- 
2. Wipe the shaft and the rotor hub to remove excess grease or other contaminants.

A light oil coating is acceptable.

## Verify Machine Mounting Dimensions

Verify proper fit of the motor to the machine mount by measuring the following machine mounting dimensions:

1. Verify these dimensions are within the measurement range in the tables:
  - Pilot diameter
  - Shaft diameter, large and small
  - Shaft length, small and overall
2. Verify the Total Indicator Readout (TIR) of these dimensions is less than the value in the tables when measured with a dial indicator:
  - Shaft runout
  - Pilot concentricity
  - Mounting surface perpendicularity

### Machine Mounting Dimensions

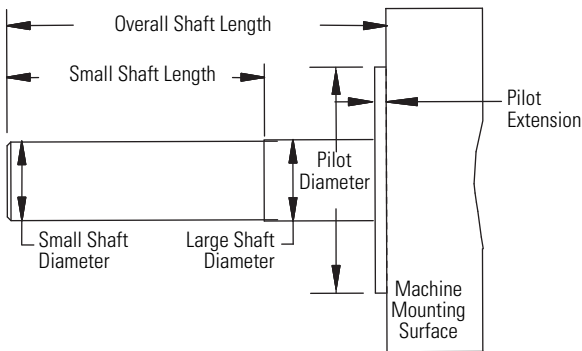

**RDB-B2901, RDB-B2902, RDB-B2903 Machine Mounting Dimensions**

<b>Attribute</b>	<b>Value</b>
Pilot Diameter	232.92...232.96 mm (9.170...9.172 in.)
Shaft Diameter, Small	59.988...59.999 mm (2.3617...2.3622 in.)
Shaft Diameter, Large	69.988...69.999 mm (2.7554...2.7559 in.)
Shaft Length, Small RDB-Bxxx1 RDB-Bxxx2 RDB-Bxxx3	43.81...44.07 mm (1.725...1.735 in.) 88.01...88.27 mm (3.465...3.475 in.) 124.58...124.84 mm (4.905...4.915 in.)
Shaft Length, Overall RDB-Bxxx1 RDB-Bxxx2 RDB-Bxxx3	89.42...91.42 mm (3.480...3.600 in.) 132.61...135.61 mm (5.220...5.340 in.) 169.19...172.19 mm (6.660...6.780 in.)
Shaft Runout	0.038 mm (0.0015 in.) max
Pilot Concentricity	0.05 mm (0.002 in.) max
Mounting Surface Perpendicularity	0.05 mm (0.002 in.) max

**RDB-B4101, RDB-B4102, RDB-B4103 Machine Mounting Dimensions**

<b>Attribute</b>	<b>Value</b>
Pilot Diameter	333.94...333.98 mm (13.147...13.149 in.)
Shaft Diameter, Small	69.988...69.999 mm (2.7554...2.7559 in.)
Shaft Diameter, Large	79.988...79.999 mm (3.1491...3.1496 in.)
Shaft Length, Small RDB-Bxxx1 RDB-Bxxx2 RDB-Bxxx3	40.26...40.52 mm (1.585...1.595 in.) 83.69...83.95 mm (3.295...3.305 in.) 118.49...118.75 mm (4.665...4.675 in.)
Shaft Length, Overall RDB-Bxxx1 RDB-Bxxx2 RDB-Bxxx3	112.55...115.55 mm (4.430...4.550 in.) 166.39...169.39 mm (6.550...6.670 in.) 251.99...254.99 mm (9.920...10.040 in.)
Shaft Runout	0.038 mm (0.0015 in.) max
Pilot Concentricity	0.05 mm (0.002 in.) max
Mounting Surface Perpendicularity	0.05 mm (0.002 in.) max

## Mount the Motor

Follow these steps to install a motor on the machine.

1. Insert the shaft key (provided) into the keyway of the machine shaft.

Position the point on the shaft key in the direction of the motor, and then fully seat the key in the slot.

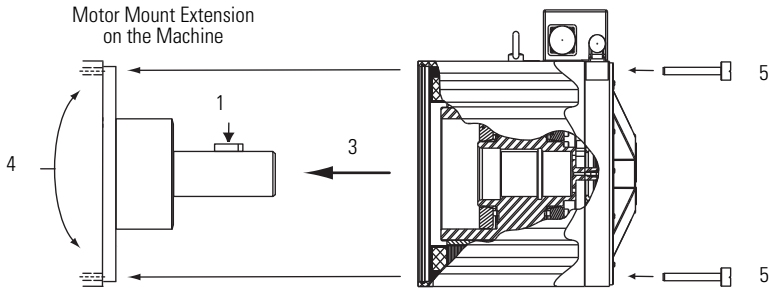

### **IMPORTANT**

When the shaft key is properly installed, it provides a rigid mechanical connection with the potential to assist in the alignment of the motor.

2. Verify the cardboard cover and protective paper sleeving are removed.
3. Slide the motor onto the shaft, and position the motor on the pilot extension of the machine.
4. Rotate the motor on the machine shaft to align the mounting holes with those on the machine.
5. Insert a fastener in each of the four (4) mounting holes in the motor faceplate, and hand-tighten each fastener to secure the motor to the machine frame.
6. Using an alternating pattern, tighten each fastener within the recommended torque range.

Cat. No.	Torque Range
RDB-x290x	50...65 N•m (40...50 lb•ft)
RDB-x410x	135...190 N•m (100...140 lb•ft)

## Remove the End Cover

Loosen each pan head screw with a Phillips screwdriver.

- The RDB-x290x motor has eight (8) screws to loosen.
- The RDB-x410x motor has eleven (11) screws to loosen.

---

**IMPORTANT**

Do not attempt to remove the pan head screws from the cover. The screws are attached to the end cover with a mechanical lock-ring.

---

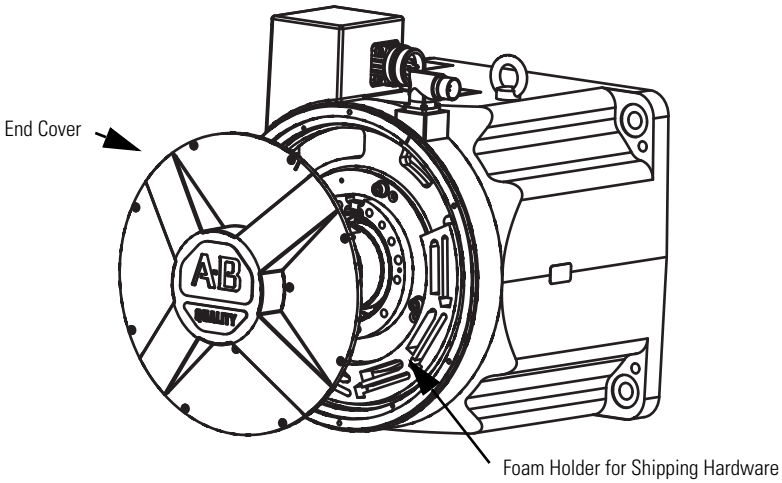

## Tighten the Compression Coupling

Follow these steps to secure the motor on the machine shaft.

1. Access the compression coupling bolts through the holes labeled A.
  - The RDB-x290x motor has six (6) bolts to tighten.
  - The RDB-x410x motor has ten (10) bolts to tighten.

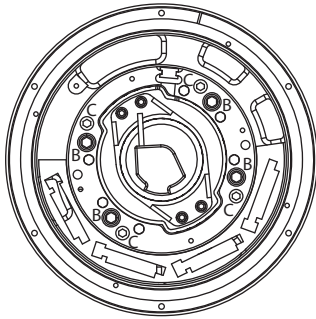

RDB-x290x with  
Rear Cover Removed

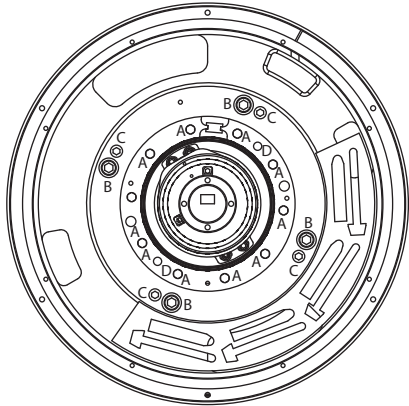

RDB-x410x with Rear Cover Removed  
(RDB-x4103 is shown)

2. Moving in a circular pattern, use a 6 mm hex bit to tighten each compression coupling bolt to the torque value shown in the table, and repeat as listed in the table.

Torque Value	Number of Repetitions
Hand-tighten - 0.1 N•m (1 lb•in.)	1x
13 N•m (10 lb•ft)	2x
20 N•m (15 lb•ft)	2x
30 N•m (22 lb•ft)	2x
30 N•m (22 lb•ft)	Until no bolt moves.

### IMPORTANT

The torque sequence requires at least eight steps to secure the compression coupling on the machine shaft. Each step gradually increases the torque value, until the final value is attained. Several steps are performed a more than once to verify the torque force is applied evenly to all bolts as they seat.

Tightening the compression coupling in this manner balances the forces applied by the compression coupling to the machine shaft. This result in a secure connection with evenly distributed forces that can be more easily released at a later time.

## Remove and Secure the Shipping Hardware

Follow these steps to remove the shipping bolts and set screws that prevent rotor movement during shipping.

1. Remove the shipping bolt from each hole B using a 6 mm hex bit, and store each bolt in the foam holder.

There are four (4) shipping bolts total. Refer to the diagram on [page 15](#) for the location of each hole B.

2. Remove the set screw from each hole C using a 6 mm hex bit, and store each screw in the foam holder.

There are four (4) set screws total. Refer to the diagram on [page 15](#) for the location of each hole C.

3. Rotate the shaft or load by hand to verify free rotation of the motor.

## Replace the End Cover

Follow these steps to align and secure the end cover in its original position.

1. Verify the O-ring is undamaged, and in position around the inside edge of the cover.
2. Carefully position the end cover over the motor opening.
3. Rotate the end cover so the alignment mark on the cover aligns with the corresponding mark on the motor housing.
4. Secure the end cover by tightening the pan head screws with a Phillips screwdriver.
  - The RDB-x290x motor has eight (8) screws to tighten.
  - The RDB-x410x motor has eleven (11) screws to tighten.



## Attach Motor Cables

Follow these steps to attach the feedback and power/brake cables after the motor is mounted.

### ATTENTION



Make sure that cables are installed and restrained to prevent uneven tension or flexing at the motor-to-cable connections.

Excessive and uneven lateral force at the motor connectors can result in the connector's environmental seal opening and closing as the cable flexes.

Failure to observe safety precautions could result in damage to the motor and its components.

1. Form a drip loop in the cable before attaching it.

A drip loop creates a low spot in the cable. Gravity causes any liquid to flow to the low spot and away from the connectors, thereby reducing the potential for any liquid to enter the connector.

2. If you use a cable with a SpeedTec plug, remove the O-ring from the motor connector.

The O-ring on the motor connector dampens the effects of vibration at the cable-to-motor connection. This creates a more secure connection for a cable with a threaded plug. O-rings interior to the threaded and SpeedTec plug provide complete environmental sealing for the cable.

Power Connector

Feedback Connector

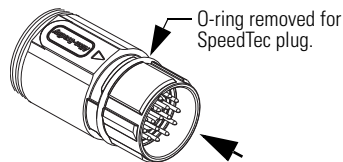
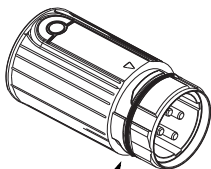

O-ring

O-ring removed for SpeedTec plug.

Align the flat surfaces before securing connection.

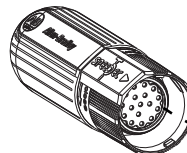
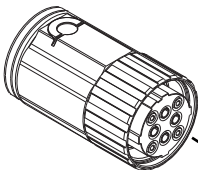

Threaded Power Plug - Install O-ring

SpeedTec Feedback Plug - Remove O-ring

### IMPORTANT

The 2090-XXNPMF-xxS.xx power cable and the 2090-XXNFMF-S.xx feedback cable require an O-ring on the motor connector.

- Carefully align the flat surface on the feedback or power/brake cable plug with the flat surface on the motor connector.

---

**IMPORTANT**

The connector orientation shown is used to clearly show the alignment marker on each cable socket.

The recommended orientation when installed positions the connectors at the bottom of the motor.

---

- Hand-tighten the collar on the plug to fully seat it on the connector.
  - The threaded plug requires five to six revolutions.
  - The SpeedTec plug requires approximately one-quarter of a revolution.

**TIP**

A fully-seated threaded plug leaves a small opening, approximately 1...4 mm (0.04...0.16 in.), between the connector and the plug.

Do not apply excessive force when mating the cable plug with the motor connector. If the plug and connector do not go together with light hand force, realign the flat surfaces and try again.

---

**ATTENTION**



Keyed connectors and cable plugs must properly align and be hand-tightened the recommended number of turns.

Improper alignment is indicated by the need for excessive force, such as the use of tools, to fully seat a plug.

Failure to observe safety precautions could result in damage to the motor and cable, and their components.

---

## Remove the Motor

Remove the motor from a machine as outlined below.

---

### **BURN HAZARD**



Outer surfaces of a motor can reach high temperatures, 125 °C (275 °F), during operation. Take precautions to prevent accidental contact with hot surfaces. Consider motor surface temperature when selecting connections and cables to install on a motor. Failure to observe safety precautions could result in personal injury or damage to equipment.

---

---

### **ATTENTION**



Servo drive power must be turned off before connecting or disconnecting the cables to the motor, and if a cable is left disconnected at the motor end. Arcing or unexpected motion could occur if the feedback, power, or brake cables are connected or disconnected while power is applied to the servo drive. Failure to observe these safety procedures could result in personal injury or damage to the motor and equipment.

---

---

## Remove the End Cover

Loosen each pan head screw with a Phillips screwdriver.

- The RDB-x290x motor has eight (8) screws to loosen.
  - The RDB-x410x motor has eleven (11) screws to loosen.
- 

### **IMPORTANT**

Do not attempt to remove the pan head screws from the cover. The screws are affixed to the end cover with a mechanical lock-ring.

---

---

## Align the Rotor

Follow these steps to align the rotor prior to removing the motor.

1. Use a flashlight to illuminate all holes (A, B and C) in the housing.

To locate the holes, refer to the diagrams on [page 15](#).

2. Turn the shaft by hand until a threaded hole directly aligns with each hole B, and the hex bolts on the compression coupling are visible through each hole A.
3. Verify each hole C shows the flat surface of the rotor.

---

**IMPORTANT**

Correct alignment of holes A and B is critical for the successful release of the compression coupling and the subsequent removal of the motor.

---

The holes are not evenly spaced. If necessary, continue to slowly rotate the shaft until the above conditions are met.

---

## Install the Set Screws and Shipping Bolts

Follow these steps to install the set screws that prevent rotor movement during shipping.

---

**ATTENTION**

Do not use a thread lock material on the shipping hardware.



- 
1. Remove each set screw from the foam holder, and insert it in a hole C.

There are four (4) set screws total. Refer to the diagram on [page 15](#) for the locations.

2. Tighten each set screw to 0.1 N•m (1 lb•in.) by hand with a 6 mm hex bit.
3. Remove each shipping bolt from the foam holder, and insert it in a hole B.

There are four (4) shipping bolts total. Refer to the diagram on [page 15](#) for the locations.

4. Tighten each shipping bolt to 16.0 N•m (142 lb•ft.) with a 6 mm hex bit. mounted on a torque wrench.

## Loosen the Compression Coupling Bolts

Follow these steps to loosen the compression coupling bolts prior to releasing the compression coupling from the shaft.

1. Access the compression coupling bolts through the holes labelled A.
  - The RDB-x290x motor has six (6) compression bolts to loosen.
  - The RDB-x410x motor has ten (10) compression bolts to loosen.

Refer to the diagram on [page 15](#) for the locations.

2. Moving in a circular pattern, use a 6 mm hex bit to loosen each compression coupling bolt.
3. Loosen each bolt two (2) revolutions beyond finger-tight.

---

**WARNING**



Loosening the compression coupling bolts more than two (2) revolutions beyond finger-tight may disengage the compression coupling from the rotor.

---

## Release the Compression Coupling

Follow these steps to loosen the respective motor from a machine shaft.

**TIP**

The RDB-x4103 motor has a two-stage compression coupling.

Release the first and second stages by performing both steps below, starting with the initial step that is common for all RDB-x290x or RDB-x410x motors.

### *RDB-x290x and RDB-x410x Motors*

1. Seat a 6 mm hex driver on the compression coupling bolt.

Access the compression coupling bolts through the holes labelled A.

- The RDB-x290x motor has six (6) compression bolts to loosen.
- The RDB-x410x motor has ten (10) compression bolts to loosen.

Refer to the diagram on [page 15](#) for the hole locations.

2. Release the compression coupling by lightly tapping the hex driver with a hammer.
3. Repeat steps 1 and 2 to the compression coupling bolt directly opposite the bolt accessed most recently.

Use this alternating pattern until all compression couplings are released.

### *RDB-x4103 Motors Only*

1. Seat a M6 x 1 x 120 screw or threaded rod into either hole D.

Access the second-stage compression coupling bolts on a RDB-x4103 motor through the holes labelled D.

The RDB-x410x motor has two (2) second-stage compression bolts.

Refer to the diagram on [page 15](#) for the hole locations.

2. Release the compression coupling by tightening the screw/rod until the coupling loosens.
3. Repeat steps 1 and 2 to the compression coupling bolt in the other hole D.

## Replace the End Cover

Follow these steps to align and secure the end cover in its original position.

1. Verify the O-ring is in position on the outside of the end cover.
2. Rotate the end cover so the alignment mark on the cover aligns with the corresponding mark on the motor housing.
3. Tighten each pan head screw to secure the end cover on the motor.
  - The RDB-x290x motor has eight (8) screws to tighten.
  - The RDB-x410x motor has eleven (11) screws to tighten.

## Remove the Motor From the Machine

Follow these steps to remove the motor from the machine shaft.

1. Remove the four (4) mounting bolts securing the motor frame to the machine.
2. Slide the motor off the machine shaft.

**TIP**

If the motor is locked to the machine, use the threaded holes adjacent to the mounting holes to separate the motor from the mounting surface of the machine. Insert at least two bolts in diagonally opposite holes to do this.

- The RDB-x290x motor has M10 holes.
- The RDB-x410x motor has M12 holes.



## Cover the Mounting End of the Motor

Seal the opening in the motor end by performing the following steps.

1. Insert the protective paper sleeving around the rotor.
2. Cover the opening at the mounting end of the motor with the cardboard cover that came with the motor.

---

**ATTENTION**

The mounting end of the motor contains magnetized materials that can attract metallic materials.

Accidental entry of foreign material can harm motor performance.

Always cover the mounting end of motor immediately after removing the motor. This prevents foreign material from accidentally entering the motor.

---

## Connector Data

These tables identify the pinouts for feedback and power connectors.

M23 EnDat Feedback	
Pin	Signal Name
1	Sin+
2	Sin-
3	Cos+
4	Cos-
5	Data+
6	Data-
7	CLK+
8	CLK-
9	EPWR 5V
10	ECOM
11	Reserved
12	Reserved
13	TS+
14	TS-
15	Reserved
16	
17	

M23 Power	
Pin	Signal Name
A	Phase U
B	Phase V
C	Phase W
⊕	Ground
E	Reserved
F	
G	
H	
L	

M40 Power	
Pin	Signal Name
U	Phase U
V	Phase V
W	Phase W
⊕	Ground
+	Reserved
-	
1	
2	

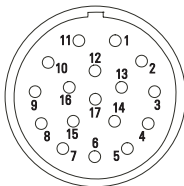

Intercontec P/N  
AEDC113NN00000202000

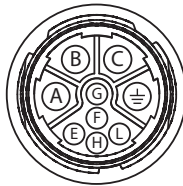

Intercontec P/N  
BEDC091NN00000202000

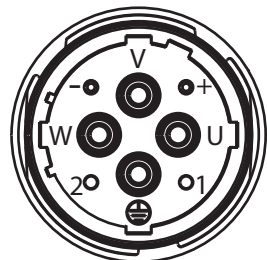

Intercontec P/N  
CEDE271NN00000051000

## Product Dimensions

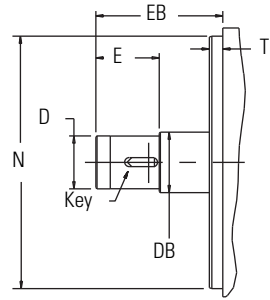
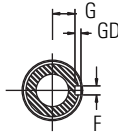
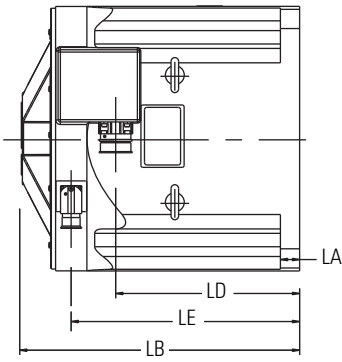

Key supplied with motor.  
Orient as shown.

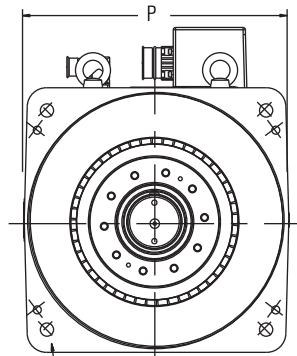
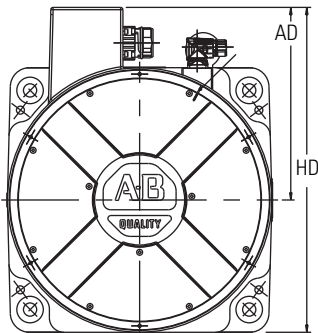
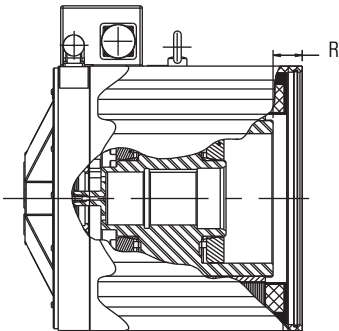

S = Dia. of Bolt Holes  
M = Dia. of Bolt Circle

The dimensions in the table are for motors with a single-turn or a multi-turn encoder. Footnotes identify tolerances and dimensional differences.

**Motor Dimensions**

Dimension mm (in.)	Motor Cat. No.					
	RDB-B2901	RDB-B2902	RDB-B2903	RDB-B4101	RDB-B4102	RDB-B4103
<b>AD max</b>	182.3 (7.18)			256.3 (10.09)		
<b>D</b>	59.988... 59.999 (2.3617... 2.3622)			69.988... 69.999 (2.7554... 2.7559)		
<b>DB</b>	69.988... 69.999 (2.7554... 2.7559)			79.988... 79.999 (3.1491... 3.1496)		
<b>E (1)</b>	43.94 (1.730)	88.14 (3.470)	124.71 (4.910)	40.39 (1.590)	83.82 (3.300)	118.62 (4.670)
<b>EB (2)</b>	89.92 (3.540)	134.11 (5.280)	170.69 (6.720)	114.05 (4.490)	167.89 (6.610)	253.49 (9.980)
<b>F</b>	11.957... 12.000 (0.4707... 0.4724)					
<b>G</b>	24.80... 24.99 (0.976... 0.984)			29.80... 29.99 (1.173... 1.181)		
<b>GD</b>	7.90... 8.00 (0.311... 0.315)					
<b>HD max</b>	305.9 (12.05)			432.1 (17.01)		
<b>LA (3)</b>	22.2 (0.88)			25.4 (1.00)		
<b>LB (4)</b>	201.2 (7.92)	250.7 (9.87)	300.5 (11.83)	229.9 (9.05)	299.0 (11.77)	368.1 (14.49)
<b>LE</b>	135.74 (5.344)	185.34 (7.297)	234.95 (9.250)	164.08 (6.460)	233.17 (9.180)	302.26 (11.90)
<b>M (5)</b>	290.0 (11.417)			410.0 (16.142)		
<b>N (6)</b>	232.94 (9.171)			333.96 (13.148)		

- (1) Tolerance for this dimension is  $\pm 0.13$  mm (0.005 in.).
- (2) Tolerance for this dimension is  $\pm 1.50$  mm (0.06 in.) static,  $\pm 0.05$  mm (0.002 in.) dynamic.
- (3) Tolerance for this dimension is  $\pm 2.15$  mm (0.085 in.).
- (4) Tolerance for this dimension is  $\pm 2.3$  mm (0.090 in.).
- (5) Total Indicator Runout (TIR) is 0.76 mm (0.030 in.).
- (6) Tolerance for this dimension is  $\pm 0.02$  mm ( $\pm 0.001$  in.).

**Motor Dimensions (cont.)**

Dimension mm (in.)	Motor Catalog No.					
	RDB-B2901	RDB-B2902	RDB-B2903	RDB-B4101	RDB-B4102	RDB-B4103
<b>P</b> <sup>(1)</sup>	245.9 (9.68)			350.0 (13.78)		
<b>R</b>	16.8 (0.66)			38.6 (1.52)		
<b>S</b>	14.0 (0.551)			17.5 (0.689)		
<b>T</b>	13.5 (0.53)			17.8 (0.70)		

(1) Tolerance for this dimension is  $\pm 1.52$  mm ( $\pm 0.060$  in.).

## Specifications

Attribute	Value
Temperature, operating	0...40 °C (32...104 °F) <sup>(2)</sup>
Temperature, storage	-30...70 °C (-22...158 °F)
Relative humidity, storage	5...95% noncondensing
Atmosphere, storage	Non-corrosive
IP rating <sup>(1)</sup>	IP65 - dust tight, water jet <sup>(3)</sup>

- (1) The motor rating excludes any reduction in the rating resulting from cables, plugs, or connections with a lower rating, and an unsealed customer machine mounting interface.
- (2) To obtain this thermal rating, mount RDB-x290 motors on a surface with heat dissipation equivalent to a 406.4 x 406.4 x 19.05 mm (16 x 16 x 0.75 in.) aluminum heatsink, or RDB-x410 motors on a surface with heat dissipation equivalent to a 508 x 508 x 19.05 mm (20 x 20 x 0.75 in.) aluminum heatsink.
- (3) International Protection Code (IP65) is roughly equivalent to a NEMA 12 (industrial use dust tight, drip tight).

## Additional Resources

These documents contain additional information concerning related Rockwell Automation products.

<b>Resource</b>	<b>Description</b>
Kinetix 6000 Multi-axis Servo Drives User Manual, publication <a href="#">2094-UM001</a>	Information on installing, configuring, starting up, and troubleshooting for your Kinetix 6000 servo drive system.
Kinetix 6200 Modular Multi-axis Servo Drives User Manual, publication <a href="#">2094-UM002</a>	Information on installing, configuring, starting up, and troubleshooting for your Kinetix 6200 servo drive system.
Kinetix 7000 Multi-axis Servo Drives User Manual, publication <a href="#">2099-UM001</a>	Information on installing, configuring, starting up, and troubleshooting for your Kinetix 7000 servo drive system.
Low-profile EnDat Feedback Module Installation Instructions, publication <a href="#">2090-IN020</a>	Information on connecting an EnDat Feedback Module to interface the feedback signal from an RDD-Series motor with a Kinetix servo drive system.
Allen-Bradley Industrial Automation Glossary, publication <a href="#">AG-7.1</a>	A glossary of industrial automation terms and abbreviations.
System Design for Control of Electrical Noise Reference Manual, publication <a href="#">GMC-BM001</a>	Information, examples, and techniques designed to minimize system failures caused by electrical noise.
Kinetix Motion Control Selection Guide, publication <a href="#">GMC-SG001</a>	Specifications, motor/servo-drive system combinations, and accessories for Kinetix motion control products.

You can view or download publications at <http://literature.rockwellautomation.com>. To order paper copies of technical documentation, contact your local Rockwell Automation distributor or sales representative.

# Rockwell Automation Support

Rockwell Automation provides technical information on the Web to assist you in using its products. At <http://support.rockwellautomation.com>, you can find technical manuals, a knowledge base of FAQs, technical and application notes, sample code and links to software service packs, and a MySupport feature that you can customize to make the best use of these tools.

For an additional level of technical phone support for installation, configuration and troubleshooting, we offer TechConnect support programs. For more information, contact your local distributor or Rockwell Automation representative, or visit <http://support.rockwellautomation.com>.

## Installation Assistance

If you experience a problem within the first 24 hours of installation, please review the information that's contained in this manual. You can also contact a special Customer Support number for initial help in getting your product up and running.

United States	1.440.646.3434 Monday – Friday, 8 a.m. – 5 p.m. EST
Outside United States	Please contact your local Rockwell Automation representative for any technical support issues.

## New Product Satisfaction Return

Rockwell Automation tests all of its products to ensure that they are fully operational when shipped from the manufacturing facility. However, if your product is not functioning and needs to be returned, follow these procedures.

United States	Contact your distributor. You must provide a Customer Support case number (call the phone number above to obtain one) to your distributor in order to complete the return process.
Outside United States	Please contact your local Rockwell Automation representative for the return procedure.

Allen-Bradley, Kinetix, Rockwell Automation, RDD-Series, Rockwell Software, and TechConnect are trademarks of Rockwell Automation, Inc.

Trademarks not belonging to Rockwell Automation are property of their respective companies.

[www.rockwellautomation.com](http://www.rockwellautomation.com)

### Power, Control and Information Solutions Headquarters

Americas: Rockwell Automation, 1201 South Second Street, Milwaukee, WI 53204-2496 USA, Tel: (1) 414.382.2000, Fax: (1) 414.382.4444  
Europe/Middle East/Africa: Rockwell Automation, Vorstlaan/Boulevard du Souverain 36, 1170 Brussels, Belgium, Tel: (32) 2 663 0600, Fax: (32) 2 663 0640  
Asia Pacific: Rockwell Automation, Level 14, Core F, Cyberport 3, 100 Cyberport Road, Hong Kong, Tel: (852) 2887 4788, Fax: (852) 2508 1846

Publication RDB-IN002A-EN-P — October 2009

PN-51290

Copyright © 2009 Rockwell Automation, Inc. All rights reserved. Printed in the U.S.A.