

# **RDD-Series Rotary Direct Drive Bearingless Motors**

Catalog Numbers RDB-B2151, RDB-B2152, RDB-B2153

<b>Topic</b>	<b>Page</b>
Important User Information	2
Catalog Number Explanation	3
Before You Begin	4
Install the Motor	8
Remove the Motor	16
Connector Data	18
Product Dimensions	19
Specifications	21
Additional Resources	22

## **About the Rotary Direct Drive Bearingless Motors**

RDD-Series direct drive motors feature single-turn or multi-turn high resolution encoders. These bearingless housed motors provide a compact design for direct drive applications.

## Important User Information

Solid state equipment has operational characteristics differing from those of electromechanical equipment. Safety Guidelines for the Application, Installation and Maintenance of Solid State Controls, publication [SGL-1.1](#), is available from your local Rockwell Automation sales office or online at <http://literature.rockwellautomation.com>, describes some important differences between solid state equipment and hard-wired electromechanical devices. Because of this difference, and also because of the wide variety of uses for solid state equipment, all persons responsible for applying this equipment must satisfy themselves that each intended application of this equipment is acceptable.





In no event will Rockwell Automation, Inc. be responsible or liable for indirect or consequential damages resulting from the use or application of this equipment.

The examples and diagrams in this manual are included solely for illustrative purposes. Because of the many variables and requirements associated with any particular installation, Rockwell Automation, Inc. cannot assume responsibility or liability for actual use based on the examples and diagrams.

No patent liability is assumed by Rockwell Automation, Inc. with respect to use of information, circuits, equipment, or software described in this manual.

Reproduction of the contents of this manual, in whole or in part, without written permission of Rockwell Automation, Inc., is prohibited.

Throughout this manual, when necessary, we use notes to make you aware of safety considerations.

<b>WARNING</b> 	Identifies information about practices or circumstances that can cause an explosion in a hazardous environment, which may lead to personal injury or death, property damage, or economic loss.
<b>IMPORTANT</b>	Identifies information that is critical for successful application and understanding of the product.
<b>ATTENTION</b> 	Identifies information about practices or circumstances that can lead to personal injury or death, property damage, or economic loss. Attentions help you identify a hazard, avoid a hazard and recognize the consequences.
<b>SHOCK HAZARD</b> 	Labels may be on or inside the equipment, for example, a drive or motor, to alert people that dangerous voltage may be present.
<b>BURN HAZARD</b> 	Labels may be on or inside the equipment, for example, a drive or motor, to alert people that surfaces may reach dangerous temperatures.

## Catalog Number Explanation

### R DB - B 215 3 F - 7 B 7 2 AA

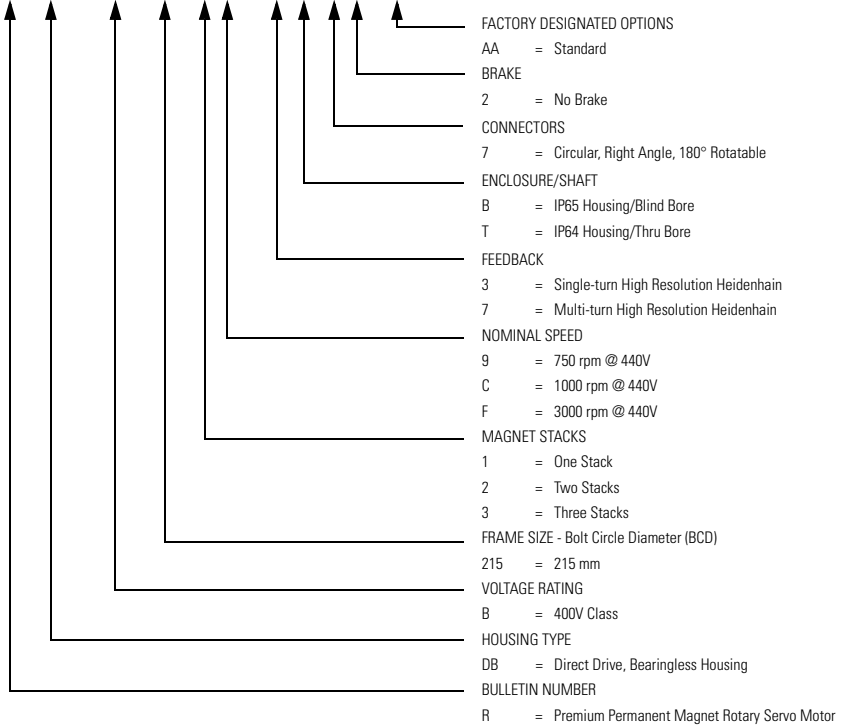

## Before You Begin

Remove all packing material, wedges, and braces from within and around the item. After unpacking, verify the nameplate catalog number against the purchase order.

1. Remove the motor carefully from its shipping container.
2. Visually inspect the motor frame, mounting pilot, and connectors for damage.
3. Notify the carrier of any shipping damage immediately.
4. Retain the cardboard cover and protective paper sleeving from the mounting end of the motor.

---

### ATTENTION



Magnetized material within the motor is exposed whenever the protective cover is removed and before the motor is mounted.

Accidental entry of foreign material can harm motor performance.

Always cover the mounting end of motor immediately after removing the motor or its protective cover. This will greatly reduce the possibility of magnetic or non-magnetic particles accidentally entering the motor.

---

## Required Tools

These tools are needed to install or remove the product.

Tools Required	Value
Hex bit, 150 mm (6 in.) minimum length	6 mm
Hex bit, 25 mm (1 in.) minimum length	8 mm
Torque wrench	Capable of applying at least 45 N•m (35 lb•ft)
Screwdriver	Phillips #4
Pry bar	Flat blade
Micrometer	N/A
Straight edge	
Caliper	
Runout indicator	
Cleaning cloth	
Flashlight	

## Prolonging Motor Life

Thoughtful design and proper maintenance can increase the life of this motor. Follow these guidelines to maximize the life of the motor:

- Always provide a drip loop in each cable to carry liquids away from the connection to the motor.
- If design requirements permit, provide shields that protect the motor housing, shaft bore, seals, and their junctions from contamination by foreign matter or fluids.
- Inspect the motor for damage or wear on a regular basis. If damage or excessive wear is observed, replace the item.

## Preventing Electrical Noise

ElectroMagnetic Interference (EMI), commonly called electrical noise, can reduce motor performance. Effective techniques to counter EMI include filtering the AC power, using shielded cables, separating signal cables from power wiring, and practicing good grounding techniques.

Follow these guidelines to avoid the effects of EMI:

- Isolate the power transformers or install line filters on all AC input power lines.
- Physically separate signal cables from motor cabling and power wiring. Do not route signal cables with motor and power wires, or over the vent openings of servo drives.
- Ground all equipment by using a single-point parallel ground system that employs ground bus bars or large straps. If necessary, use additional electrical noise reduction techniques to reduce EMI in noisy environments.

Refer to the System Design for Control of Electrical Noise Reference Manual, publication [GMC-RM001](#), for additional information on reducing the effects of EMI.

## Build and Route Cables

Knowledgeable cable routing and careful cable construction improves system performance.

Follow these guidelines to build and install cables:

- Keep wire lengths as short as physically possible.
- Route noise sensitive wiring (encoder, serial, I/O) away from input power and motor power wiring.
- Separate cables by 0.3 m (1 ft) minimum for every 9 m (30 ft) of parallel run.
- Ground both ends of the encoder cable shield and twist the signal wire pairs to prevent electromagnetic interference (EMI) from other equipment.

---

**ATTENTION**



Do not tightly gather or coil the excess length of a power cable. Heat is generated within a cable whenever power is applied. Always position a power cable so it may freely dissipate any heat.

A power cable should not be coiled, except for temporary use when building or testing a machine. If you temporarily coil a power cable, you must also derate the cable to meet local code or follow an authoritative directive, such as Engineering Section 310.15(C) of the NEC Handbook.

Failure to observe these safety procedures could result in personal injury or equipment damage.

---

## Ground the Shielded Signal Wires within a Power Cable

Always ground the shield on any signal wires inside a power cable. Connecting this shield to chassis ground reduces the potential for voltage inductance and EMI.

### **SHOCK HAZARD**



If any shield on a power cable is not grounded, high voltage can be present on that shield.

Make sure there is a connection to ground for all shield wires inside a power cable, and for the overall power cable shield.

Failure to observe safety precautions could result in personal injury or damage to equipment.

To ground the shield wire on a 2090-CPBM7DF-xxAFxx or 2090-XXNPMF-xxSxx power cable:

1. Loop the signal wire pair to the overall cable shield as shown in the diagram.
  - Cable 2090-CPBM7DF-xxAFxx (shown) contains one signal wire pair.
  - Cable 2090-XXNPMF-xxSxx contains two signal wire pairs.
2. Clamp all signal wire shields and the overall power-cable shield in the power cable (chassis) ground clamp on the drive.

## Grounding of Signal Wire Shields in a Power Cable

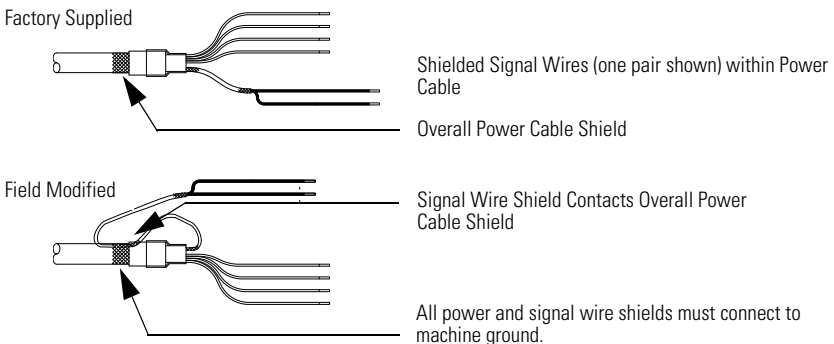

## Install the Motor

All motors include a mounting pilot for aligning the motor on the machine. Preferred fasteners are hardened steel. The installation must comply with all local regulations and use equipment and installation practices that promote safety and electromagnetic compatibility.

---

**ATTENTION**



Unmounted motors, disconnected mechanical couplings, loose shaft keys, and disconnected cables are dangerous if power is applied.

Disassembled equipment should be appropriately identified (tagged-out) and access to electrical power restricted (locked-out).

Before applying power to the motor, remove the shaft key and other mechanical couplings that could be thrown by the motor.

Failure to observe these safety precautions could result in personal injury.

---

**ATTENTION**



Servo drive power must be turned off before connecting or disconnecting the cables to the motor, and if a cable is left disconnected at the motor end.

Arcing or unexpected motion could occur if the feedback, power, or brake cables are connected or disconnected while power is applied to the servo drive.

Failure to observe these safety procedures could result in personal injury or damage to the motor and equipment.

---

**ATTENTION**



Do not attempt to open or modify this motor.

Only an authorized Allen-Bradley repair center shall service this item. Refer to Rockwell Automation Support for assistance to locate the nearest repair center.

Failure to observe safety precautions could result in personal injury or damage to equipment.

---



## Prepare the Motor for Installation

Follow these steps to prepare a motor for installation.

1. Verify sufficient clearance, heatsink mass, and air flow for the motor so it stays within the operating temperature range of 0...40 °C (32...104 °F).

Do not enclose the motor unless cooling air is forced across the motor, and keep other heat producing devices away from the motor. Heatsink requirements are listed in a footnote to the [Specifications](#) table.

---

**BURN HAZARD**

Outer surfaces of a motor can reach high temperatures, 125 °C (275 °F), during operation.

Take precautions to prevent accidental contact with hot surfaces. Consider motor surface temperature when selecting connections and cables to install on a motor.

Failure to observe safety precautions could result in personal injury or damage to equipment.

- 
2. Wipe the machine shaft and motor bore to remove excess grease or contaminants.

A light oil coating is acceptable.

## Verify Machine Mounting Dimensions

Verify proper fit of the motor to the machine mount by measuring the following machine mounting dimensions.

1. Verify these dimensions are within the measurement range in the table:
  - Pilot diameter
  - Shaft diameter, small and large
  - Shaft length, small and overall
2. Verify the Total Indicator Readout (TIR) of these dimensions is less than the value in the table when measured with a dial indicator:
  - Shaft runout
  - Pilot concentricity
  - Mounting surface perpendicularity

## Machine Mounting Dimensions

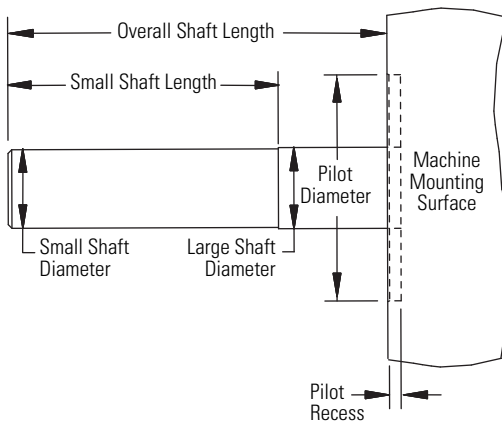

**RDB-B2151, RDB-B2152, RDB-B2153 Machine Mounting Dimensions**

<b>Attribute</b>	<b>Value</b>
Pilot diameter	164.040...164.090 mm (6.4583...6.4602 in.)
Shaft diameter, small	70.985...71.000 mm (2.7947...2.7953 in.)
Shaft diameter, large	71.985...72.000 mm (2.8340...2.8346 in.)
Shaft length, small RDB-B2151 RDB-B2152 RDB-B2153	48.60...49.40 mm (1.915...1.945 in.) 82.60...83.40 mm (3.255...3.285 in.) 116.60...117.40 mm (4.595...4.625 in.)
Shaft length, overall RDB-B2151 RDB-B2152 RDB-B2153	102.5...105.5 mm (4.031...4.149 in.) 136.5...139.5 mm (5.371...5.489 in.) 170.5...173.5 mm (6.711...6.829 in.)
Shaft runout	0.13 mm (0.005 in.) max
Pilot concentricity	0.10 mm (0.004 in.) max
Mounting surface perpendicularity	0.10 mm (0.004 in.) max

## Mount the Motor

Follow the diagram and steps below to install a motor on the machine.

---

**IMPORTANT**

The preferred motor-mounting orientation is with the feedback and power connectors on the bottom of the motor. The preferred orientation improves environmental protection. Alternate alignment ports are shown in the [Product Dimensions](#) drawing.

---

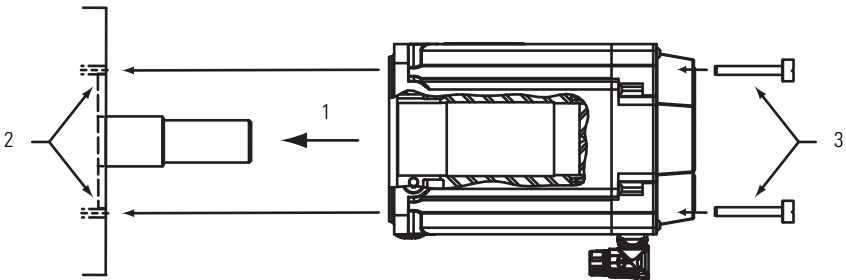

Step	Description
1	Center motor on shaft.
2	Position motor on machine shaft and mate pilot with machine recess.
3	Using an alternating pattern, insert and tighten fasteners.

## Tighten the Compression Coupling

Follow these steps to secure the motor on the machine shaft.

1. Remove the black cap screw from the hole labeled A using a Phillips #4 screwdriver. Refer to the motor outline on page 19 for the location of the compression coupling fitting and alignment screw.
2. Use a 6 mm hex bit to tighten the compression coupling in hole A to 29.8 N•m (22 lb•ft).

### ATTENTION



Improper torque values may cause the machine shaft to slip in the compression coupling. This may generate sufficient friction and heat to permanently weld the motor hub to the machine shaft.

Failure to observe this safety precaution could result in damage to the motor and the machine.

## Secure the Shipping Hardware

Follow these steps to secure loose hardware used during motor installation and to prepare the motor for use.

1. Remove the silver shipping alignment pin from hole B, and insert it in hole A.
2. Insert the black cap screw in hole B.
3. Tighten the alignment pin and the cap screw to the value specified in this table.

Motor Cat. No.	Fastener Type	Torque Value
RDB-B215x	Alignment pin with 8 mm hex head	18.0 N•m (13 lb•ft)
RDB-B215x	Cap screw	3.4 N•m (2.5 lb•ft)

4. Rotate the machine shaft or load by hand to verify free rotation of the motor.

## Attach the Motor Cables

Follow these steps to attach the feedback and power/brake cables after the motor is mounted.

### ATTENTION



Make sure that cables are installed and restrained to prevent uneven tension or flexing at the motor-to-cable connections.

Excessive and uneven lateral force at the motor connectors can result in the connector's environmental seal opening and closing as the cable flexes.

Failure to observe safety precautions could result in damage to the motor and its components.

1. Form a drip loop in the cable before attaching it.

A drip loop creates a low spot in the cable. Gravity causes any liquid to flow to the low spot and away from the connectors, thereby reducing the potential for any liquid to enter the connector.

2. Determine if you should remove the O-ring from the motor connectors.
  - Threaded plugs (power or feedback) require an O-ring.
  - SpeedTec plugs (power or feedback) do not require an O-ring.

The O-ring on the motor connector dampens the effects of vibration at the cable-to-motor connection. This creates a more secure connection for a cable with a threaded plug. O-rings interior to the threaded and SpeedTec plug provide complete environmental sealing for the connection.

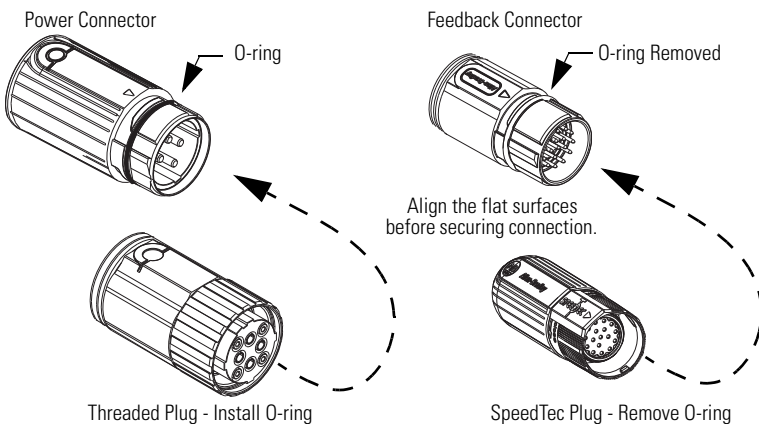

### IMPORTANT

The 2090-XXNPMF-xxSxx power cable and the 2090-XXNFMF-Sxx feedback cable require an O-ring on the motor connector.

- Carefully align the flat surface on the feedback or power/brake cable plug with the flat surface on the motor connector.

**IMPORTANT**

The connector orientation shown is used to clearly show the alignment marker on each cable socket.

The recommended orientation when installed positions the connectors at the bottom of the motor.

- Hand tighten the collar on the plug to fully seat it on the connector.
  - The threaded plug requires five to six revolutions.
  - The SpeedTec plug requires approximately one-quarter of a revolution.

**TIP**

A fully-seated threaded plug leaves a small opening, approximately 1...4 mm (0.04...0.16 in.), between the connector and the plug.

Do not apply excessive force when mating the cable plug with the motor connector. If the plug and connector do not go together with light hand force, realign the flat surfaces and try again.

**ATTENTION**

Keyed connectors and cable plugs must properly align and be hand-tightened the recommended number of turns.

Improper alignment is indicated by the need for excessive force, such as the use of tools, to fully seat a plug.

Failure to observe safety precautions could result in damage to the motor and cable, and their components.

## Remove the Motor

Follow these steps to remove a motor from a machine.

### BURN HAZARD



Outer surfaces of a motor can reach high temperatures, 125 °C (275 °F), during operation. Take precautions to prevent accidental contact with hot surfaces. Consider motor surface temperature when selecting connections and cables to install on a motor. Failure to observe safety precautions could result in personal injury or damage to equipment.

### ATTENTION



Servo drive power must be turned off before connecting or disconnecting the cables to the motor, and if a cable is left disconnected at the motor end. Arcing or unexpected motion could occur if the feedback, power, or brake cables are connected or disconnected while power is applied to the servo drive. Failure to observe these safety procedures could result in personal injury or damage to the motor and equipment.

## Align the Rotor

Follow these steps to align the rotor prior to dismounting the motor.

1. Remove the black cap screw from hole B.

Refer to the motor outline on page 19 for the location of the compression coupling fitting and alignment screw.

2. Use a flashlight to illuminate hole B.
3. Rotate the shaft by hand until the hole for the alignment pin comes into view.
4. Remove the alignment pin from hole A, and install it in hole B.

### IMPORTANT

The alignment pin must fully engage the rotor. The shoulder of the alignment pin engages the rotor when the pin is fully inserted.

5. Use a 8 mm hex bit to tighten the alignment pin in hole B to 18.0 N•m (13 lb•ft). **TBD** -> UPDATE CONDITIONAL TEXT and TABLE for 130/165 data.



## Release the Compression Coupling

Follow these steps to release the compression coupling prior to dismounting the motor.

1. Use a 6 mm hex bit to loosen the compression coupling in hole A.
2. Loosen the compression coupling one complete revolution beyond finger-tight to be sure the coupling releases from the machine shaft.
3. Secure the black cap screw in hole A by tightening it to 3.4 N•m (2.5 ft•lb).

## Remove the Motor From the Machine

Follow these steps to remove the motor and to cover the opening before storing it.

1. Remove the fastener from each of the four mounting holes in the motor faceplate.
2. Slide the motor off the machine shaft.

**TIP**

Notches in the motor-mounting surfaces provide a means to **gently** pry the motor loose from the machine.

A flat-bladed pry bar may be used to loosen the motor.

## Cover the Mounting End of the Motor

Seal the opening in the motor by performing the following steps.

1. Insert the protective paper sleeving around the rotor.
2. Cover the opening at the mounting end of the motor with the cardboard cover that came with the motor.

**ATTENTION**

Magnetized material within the motor is exposed whenever the protective cover is removed and before the motor is mounted.

Accidental entry of foreign material can harm motor performance.

Always cover the mounting end of motor immediately after removing the motor or its protective cover. This will greatly reduce the possibility of magnetic or non-magnetic particles accidentally entering the motor.

---

## Connector Data

These tables identify the pinouts for feedback and power connectors.

M23 EnDat Feedback <sup>(1)</sup>	
Pin	Signal Name
1	Sin+
2	Sin-
3	Cos+
4	Cos-
5	Data+
6	Data-
7	CLK+
8	CLK-
9	EPWR 5V
10	ECOM
11	Reserved
12	Reserved
13	TS+
14	TS-
15	Reserved
16	
17	

M23 Power	
Pin	Signal Name
A	Phase U
B	Phase V
C	Phase W
⊕	Ground
E	Reserved
F	
G	
H	
L	

M40 Power	
Pin	Signal Name
U	Phase U
V	Phase V
W	Phase W
⊕	Ground
+	Reserved
-	
1	
2	

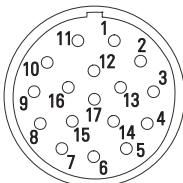

Intercontec P/N  
AEDC113NN00000202000



Intercontec P/N  
BEDC091NN00000202000

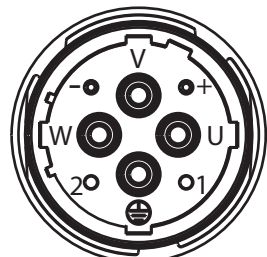

Intercontec P/N  
CEDE271NN00000051000

(1) Use a Low-profile EnDat Feedback Module to interface the feedback signal between this motor and a Kinetix drive. The module provides bi-directional feedback signal conversion between the EnDat encoding of a rotary direct drive motor and the Hyperface encoding format compatible with Kinetix drives. Refer to [Additional Resources](#) on [page 22](#) for information that describes how to interface the EnDat Feedback Module with compatible drives.

## Product Dimensions

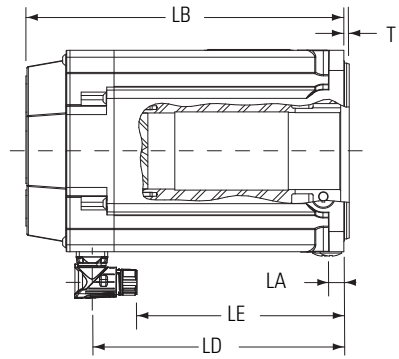
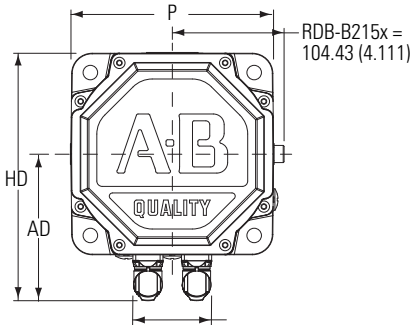

RDB-B215x with Connector Size:  
 M23 Fdbk and M23 Pwr = 73.1 mm (2.88 in.)  
 M23 Fdbk and M40 Pwr = **TBD** mm (**TBD** in.)

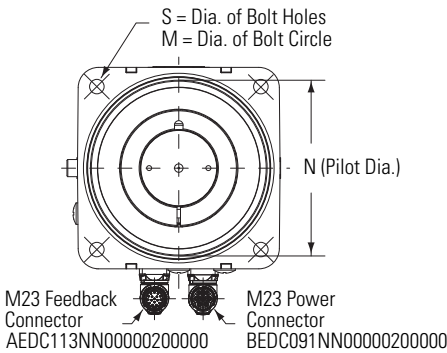
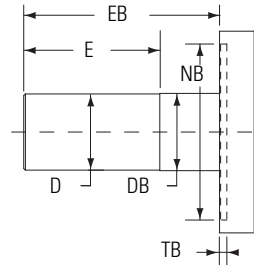
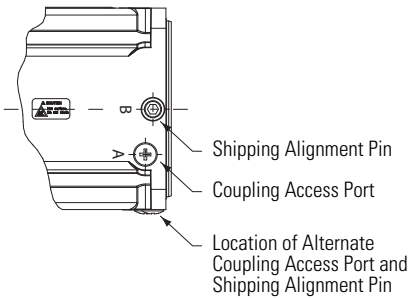

The tables list dimensions for bearingless motors with a single-turn or multi-turn encoder. Footnotes provide tolerances for the common dimensions.

**Bearingless Motor Dimensions**

<b>Cat No. RDB-</b>	<b>AD <sup>(1)</sup> Max mm (in.)</b>	<b>D mm (in.)</b>	<b>E <sup>(2)</sup> mm (in.)</b>	<b>EB <sup>(3)</sup> mm (in.)</b>	<b>HD <sup>(4)</sup> mm (in.)</b>	<b>LA mm (in.)</b>	<b>LB <sup>(5)</sup> mm (in.)</b>	<b>LD <sup>(6)</sup> mm (in.)</b>
B2151	136.70 (5.38)	71.0 (2.7953)	49.0 (1.93)	104.0 (4.09)	230.16 (9.062)	14.0 (0.55)	226.05 (8.90)	165.70 (6.524)
B2152			83.0 (3.27)	138.0 (5.43)			260.05 (10.238)	199.70 (7.862)
B2153			117.0 (4.61)	172.0 (6.77)			294.05 (11.577)	233.70 (9.201)

- (1) For motors with a M40 power connector the max dimension is 250.46 (9.861).
- (2) Tolerance for this dimension is ±0.4 mm (0.015 in.).
- (3) Tolerance for this dimension is ±1.50 mm (0.059 in.) static, ±0.13 mm (0.005 in.) dynamic.
- (4) For motors with the M40 power connector (catalog numbers RDB-B2151F, RDB-B2152F, RDB-B2153C, and RDB-B42153E) add 20.30 (0.799) to this dimension.
- (5) Tolerance for this dimension is ±0.052 mm (0.02 in.).
- (6) Tolerance for this dimension is ±0.26 mm (0.01 in.).

<b>Cat No. RDB-</b>	<b>M <sup>(1)</sup> mm (in.)</b>	<b>N <sup>(2)</sup> mm (in.)</b>	<b>NB mm (in.)</b>	<b>P <sup>(3)</sup> mm (in.)</b>	<b>S <sup>(4)</sup> mm (in.)</b>	<b>T mm (in.)</b>	<b>TB Min <sup>(5)</sup> mm (in.)</b>
B2151	215.00 (8.465)	164.000 (6.4567)	164.040...164.090 (6.4583...6.4602)	188.0 (7.402)	13.500 (0.5315)	5.00 (0.197)	5.5 (0.22)
B2152							
B2153							

- (1) Total Indicator Runout (TIR) is 0.25 mm (0.010 in.).
- (2) Tolerance for this dimension is +0.014, -0.011 mm (+0.0005, -0.0004 in.).
- (3) Tolerance for this dimension is ±1.0 mm (±0.0393 in.).
- (4) Tolerance for this dimension is +0.430, -0.0000 mm(+0.0169, -0.0000 in.).
- (5) Measurement is the minimum for this dimension.

## Specifications

Attribute	Value
Temperature, operating	0...40 °C (32...104 °F) <sup>(2)</sup>
Temperature, storage	-30...70 °C (-22...158 °F)
Relative humidity, storage	5...95% noncondensing
Atmosphere, storage	Non-corrosive
IP rating <sup>(1)</sup>	IP65 - dust tight, water jet <sup>(3)</sup>

(1) The motor rating excludes any reduction in the rating resulting from cables, plugs, or connections with a lower rating, and an unsealed customer machine mounting interface.

(2) To obtain this thermal rating, mount RDB-x215 motors on a surface with heat dissipation equivalent to a 457.2 x 457.2 x 12.7 mm (18 x 18 x 0.5 in.) aluminum heatsink.

(3) International Protection Code (IP65) is roughly equivalent to a NEMA 12 (industrial use dust tight, drip tight).

## Additional Resources

These documents contain additional information concerning related Rockwell Automation products.

Resource	Description
Kinetix 6000 Multi-axis Servo Drives User Manual, publication <a href="#">2094-UM001</a>	Information on installing, configuring, starting up, and troubleshooting for your Kinetix 6000 servo drive system.
Kinetix 6200 Multi-axis Servo Drives User Manual, publication <a href="#">2094-UM002</a>	Information on installing, configuring, starting up, and troubleshooting for your Kinetix 6200 servo drive system.
Kinetix 7000 Multi-axis Servo Drives User Manual, publication <a href="#">2099-UM001</a>	Information on installing, configuring, starting up, and troubleshooting for your Kinetix 7000 servo drive system.
Low-profile EnDat Feedback Module Installation Instructions, publication <a href="#">2090-IN020</a>	Information on connecting an EnDat Feedback Module to interface the feedback signal from an RDD-Series motor with a Kinetix servo drive system.
Allen-Bradley Industrial Automation Glossary, publication <a href="#">AG-7.1</a>	A glossary of industrial automation terms and abbreviations.
System Design for Control of Electrical Noise Reference Manual, publication <a href="#">GMC-BM001</a>	Information, examples, and techniques designed to minimize system failures caused by electrical noise.
Kinetix Motion Control Selection Guide, publication <a href="#">GMC-SG001</a>	Specifications, motor/servo-drive system combinations, and accessories for Kinetix motion control products.

You can view or download publications at <http://literature.rockwellautomation.com>. To order paper copies of technical documentation, contact your local Rockwell Automation distributor or sales representative.

## **Notes:**

# Rockwell Automation Support

Rockwell Automation provides technical information on the Web to assist you in using its products. At <http://support.rockwellautomation.com>, you can find technical manuals, a knowledge base of FAQs, technical and application notes, sample code and links to software service packs, and a MySupport feature that you can customize to make the best use of these tools.

For an additional level of technical phone support for installation, configuration and troubleshooting, we offer TechConnect support programs. For more information, contact your local distributor or Rockwell Automation representative, or visit <http://support.rockwellautomation.com>.

## Installation Assistance

If you experience a problem within the first 24 hours of installation, please review the information that's contained in this manual. You can also contact a special Customer Support number for initial help in getting your product up and running.

United States	1.440.646.3434 Monday – Friday, 8 a.m. – 5 p.m. EST
Outside United States	Please contact your local Rockwell Automation representative for any technical support issues.

## New Product Satisfaction Return

Rockwell Automation tests all of its products to ensure that they are fully operational when shipped from the manufacturing facility. However, if your product is not functioning and needs to be returned, follow these procedures.

United States	Contact your distributor. You must provide a Customer Support case number (call the phone number above to obtain one) to your distributor in order to complete the return process.
Outside United States	Please contact your local Rockwell Automation representative for the return procedure.

Allen-Bradley, Kinetix, Rockwell Automation, RDD-Series, Rockwell Software, and TechConnect are trademarks of Rockwell Automation, Inc.

Trademarks not belonging to Rockwell Automation are property of their respective companies.

[www.rockwellautomation.com](http://www.rockwellautomation.com)

### Power, Control and Information Solutions Headquarters

Americas: Rockwell Automation, 1201 South Second Street, Milwaukee, WI 53204-2496 USA, Tel: (1) 414.382.2000, Fax: (1) 414.382.4444

Europe/Middle East/Africa: Rockwell Automation, Vorstlaan/Boulevard du Souverain 36, 1170 Brussels, Belgium, Tel: (32) 2 663 0600, Fax: (32) 2 663 0640

Asia Pacific: Rockwell Automation, Level 14, Core F, Cyberport 3, 100 Cyberport Road, Hong Kong, Tel: (852) 2887 4788, Fax: (852) 2508 1846

Publication RDB-IN001A-EN-P — October 2009

PN-51289

Copyright © 2009 Rockwell Automation, Inc. All rights reserved. Printed in the U.S.A.