

SCALE 0.500

IP20, NEMA/UL TYPE OPEN

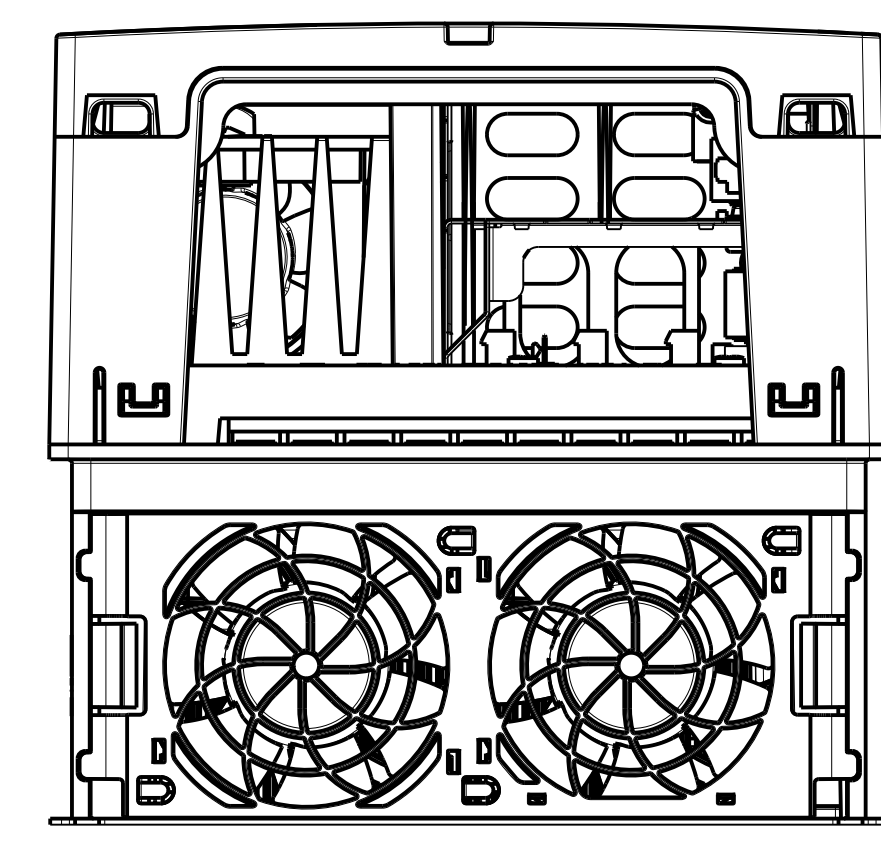

IP20, NEMA/UL TYPE OPEN

		<small>CONFIDENTIAL AND PROPRIETARY INFORMATION. THIS DOCUMENT CONTAINS CONFIDENTIAL AND PROPRIETARY INFORMATION OF ROCKWELL AUTOMATION, INC. AND MAY NOT BE USED, COPIED OR DISCLOSED TO OTHERS, EXCEPT WITH THE AUTHORIZED WRITTEN PERMISSION OF ROCKWELL AUTOMATION, INC.</small>	
		Sheet 1 Of 4	
<small>DESCRIPTION</small> STANDARD PF750-FRAME-4-IP20	<small>SIZE D1R</small> D	<small>VER</small> 06	<small>VER</small> 06
		<small>DRAWN BY:</small> XTAO1 <small>DATE:</small> 12-02-13	

1 2 3 4 5 6 7 8

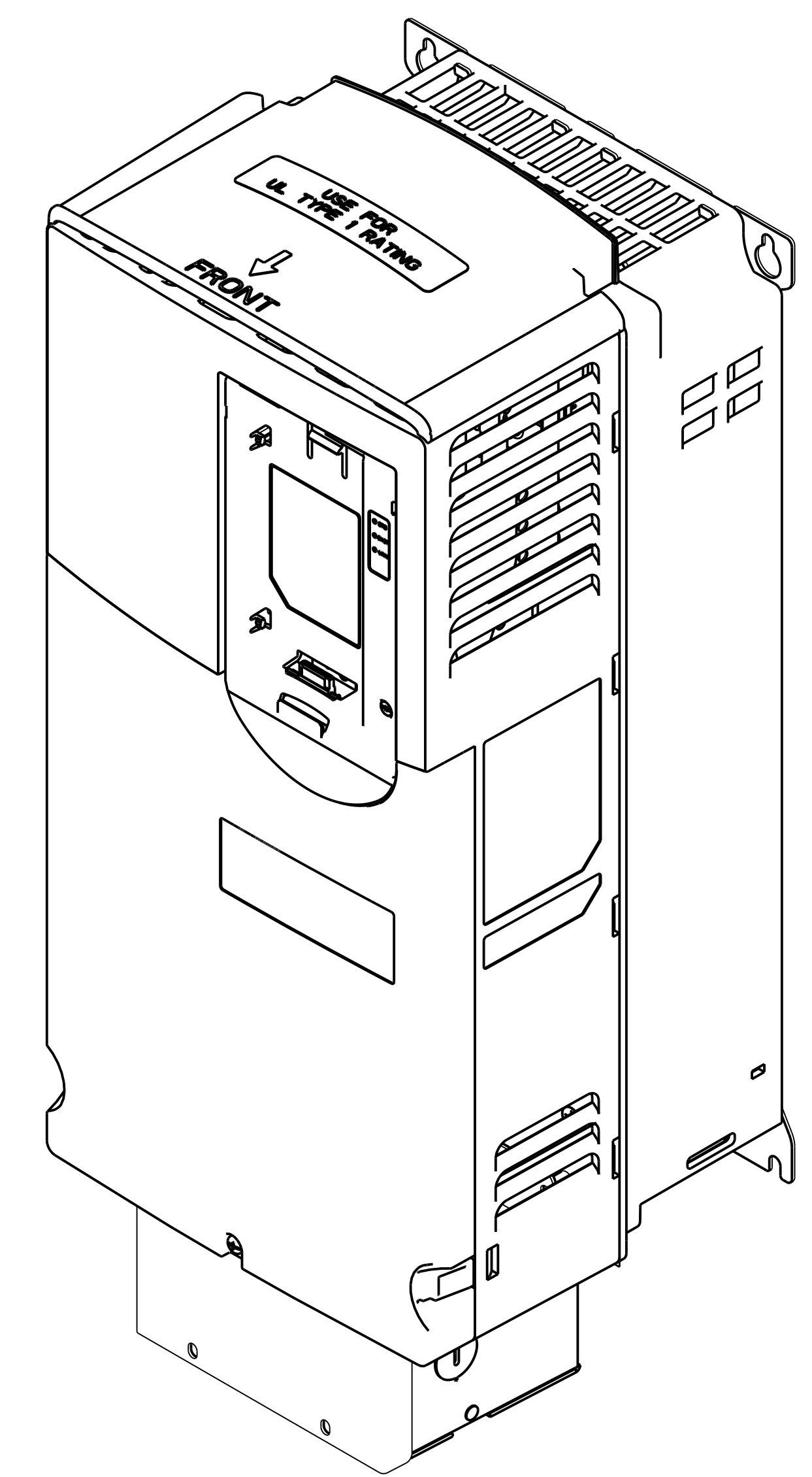
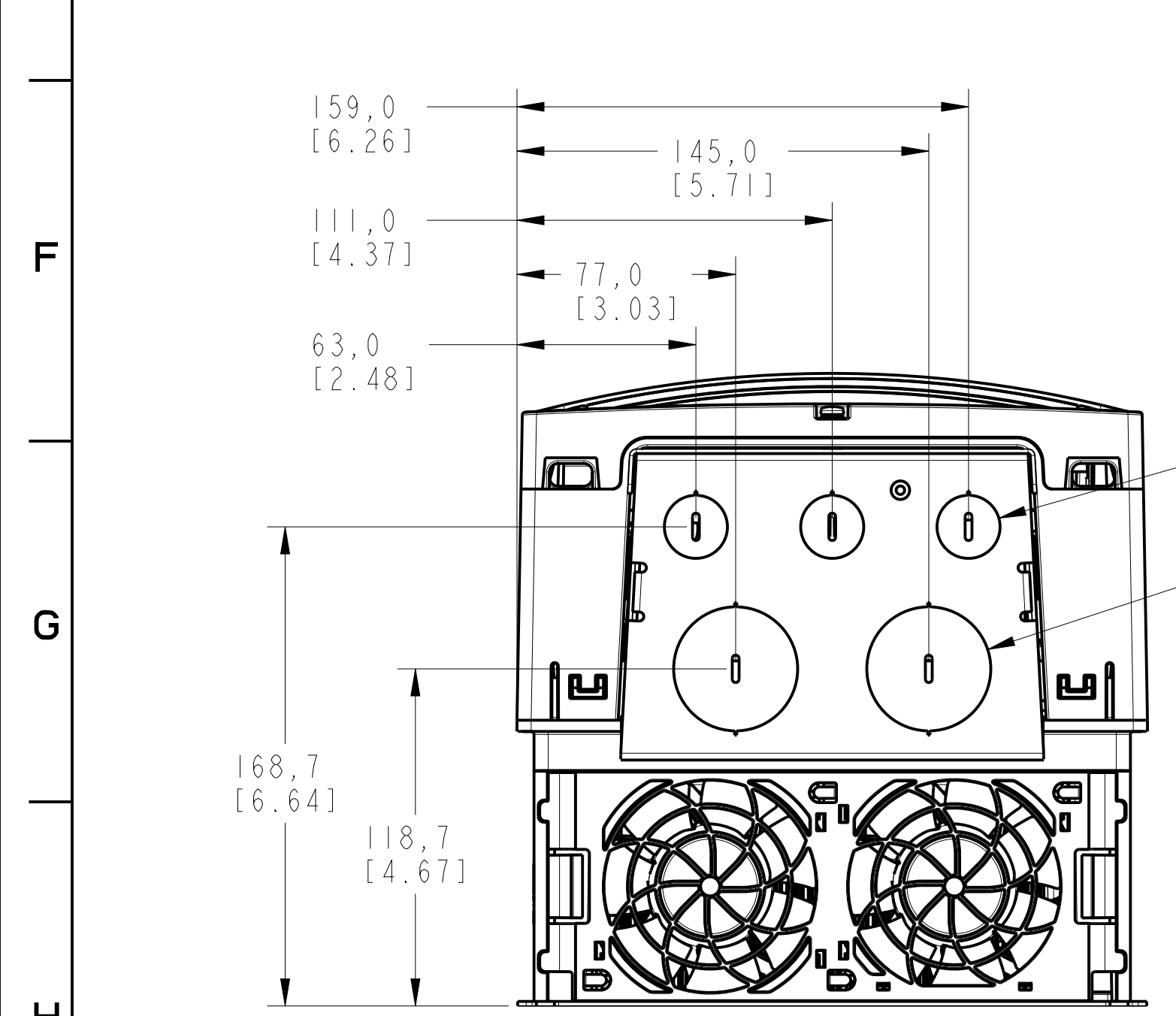
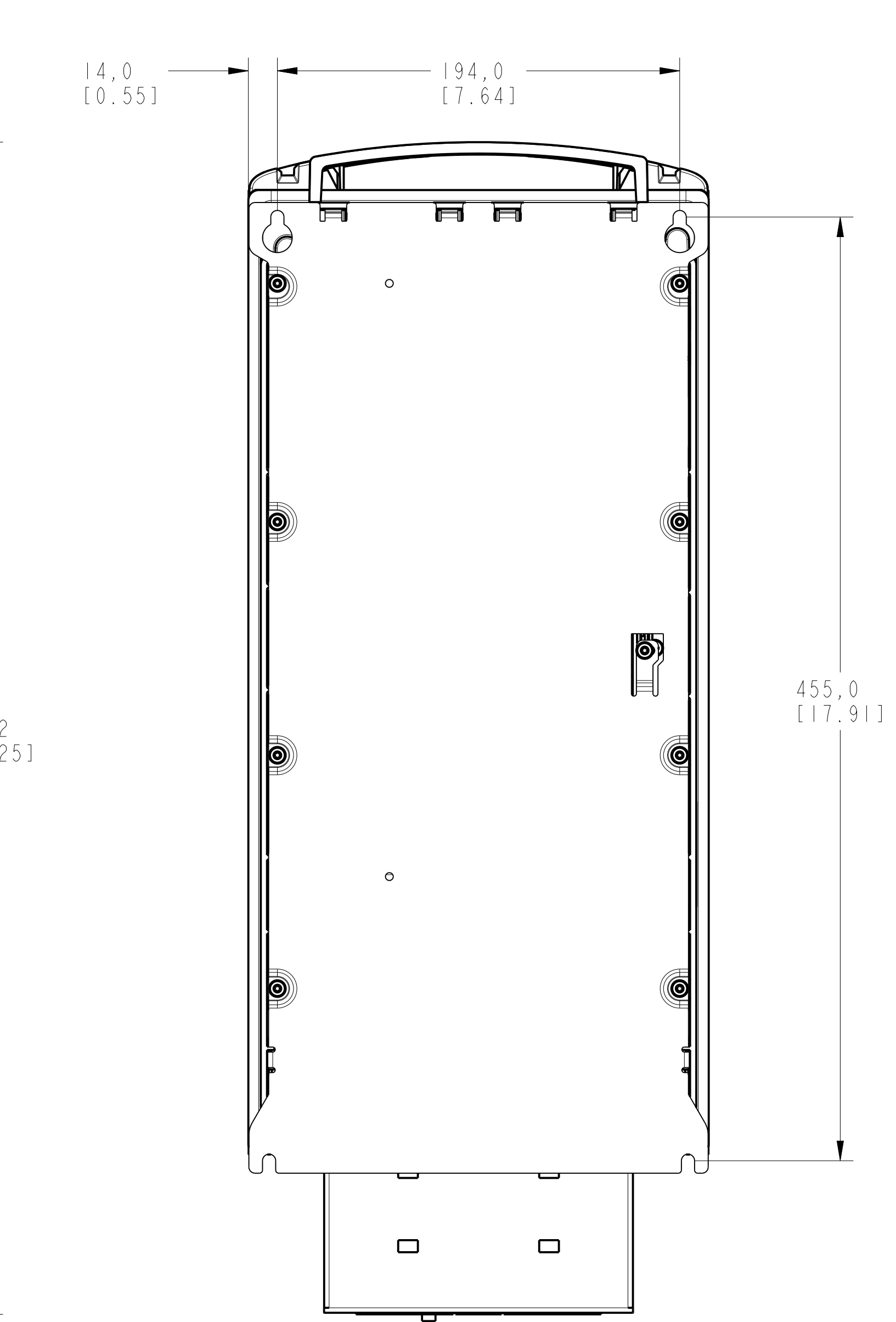
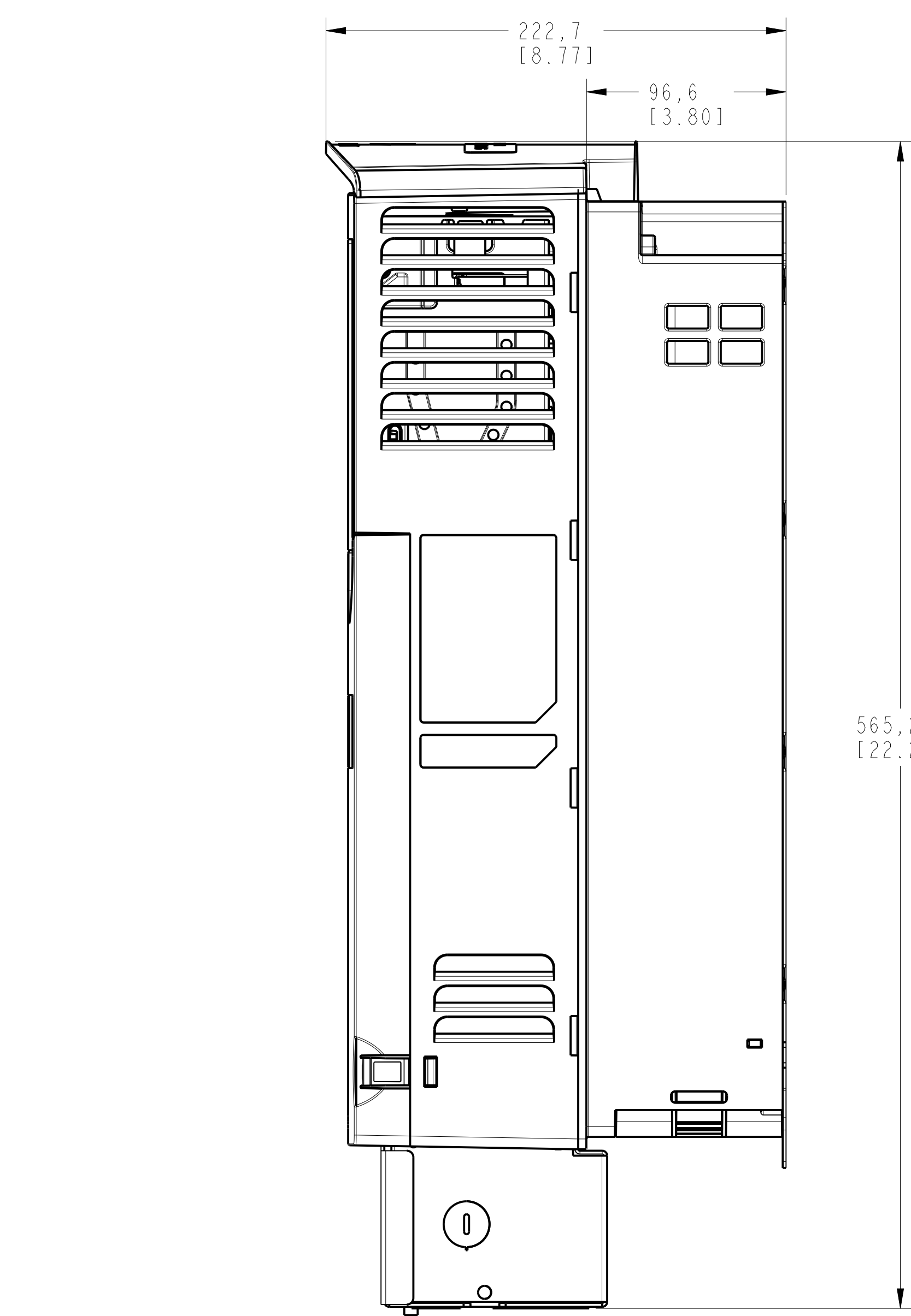
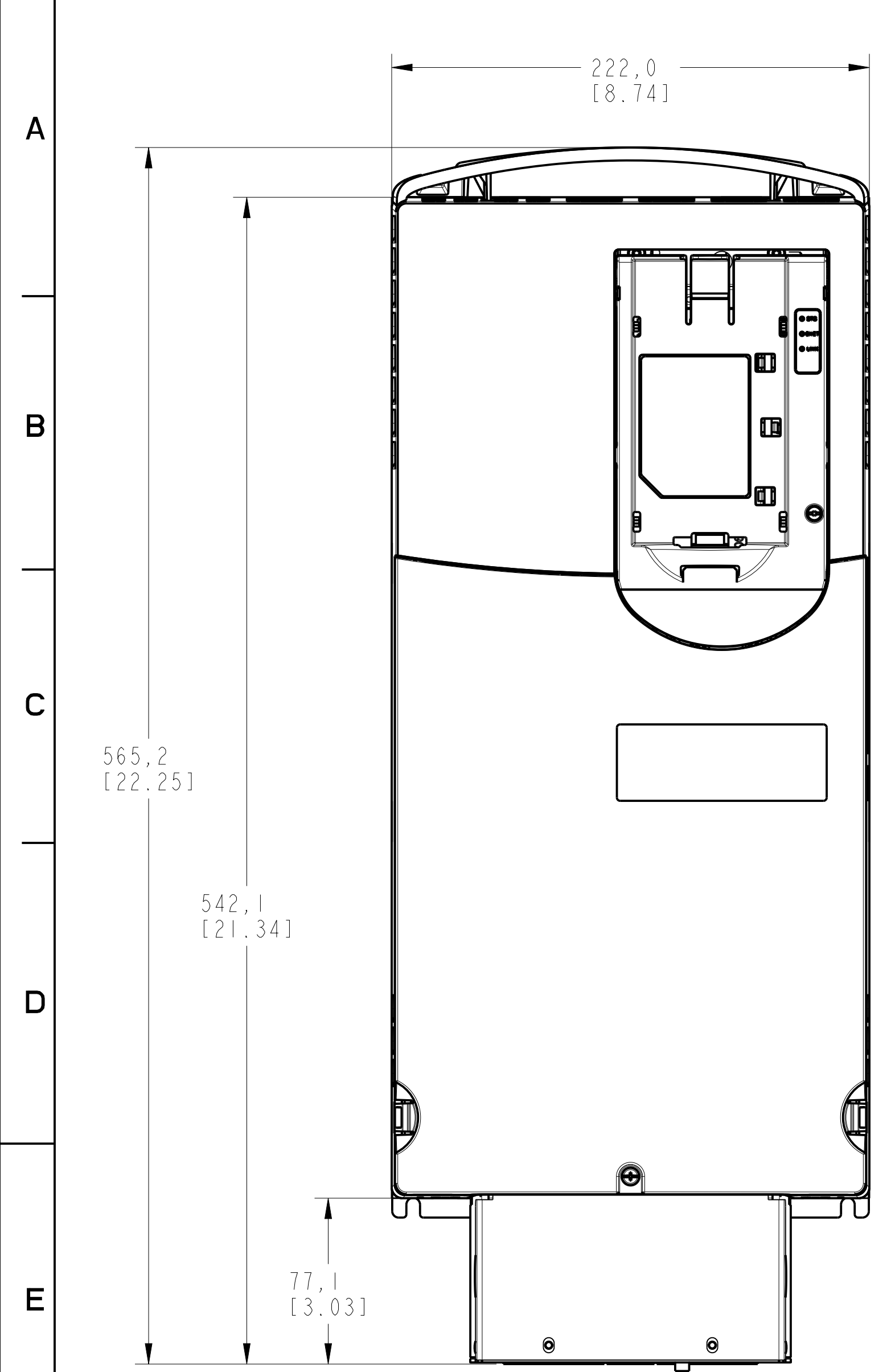

SCALE 0.500

NEMA/UL TYPE 1

NEMA/UL TYPE 1

		<small>CONFIDENTIAL AND PROPRIETARY INFORMATION THIS DOCUMENT CONTAINS CONFIDENTIAL AND PROPRIETARY INFORMATION OF ROCKWELL AUTOMATION, INC. AND MAY NOT BE USED, COPIED OR DISCLOSED TO OTHERS, EXCEPT WITH THE AUTHORIZED WRITTEN PERMISSION OF ROCKWELL AUTOMATION, INC.</small>	
		<small>DESCRIPTION</small> STANDARD PF750-FRAME-4-TYPE1	<small>Sheet 2 Of 4</small>
<small>DRAWN BY:</small> XTAO1	<small>DATE:</small> 12-02-13	<small>SIZE D1R</small> D	<small>VER</small> 06

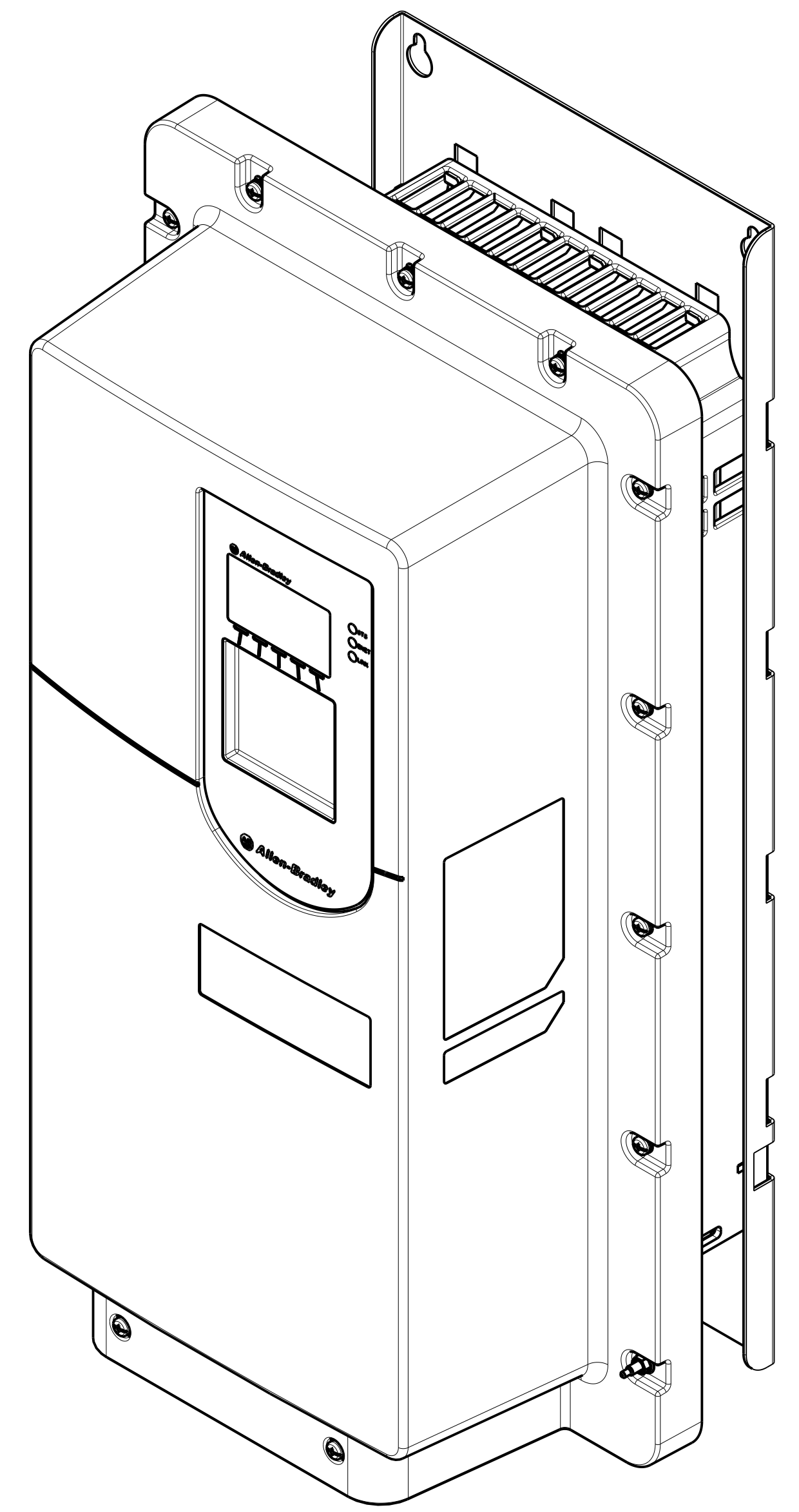
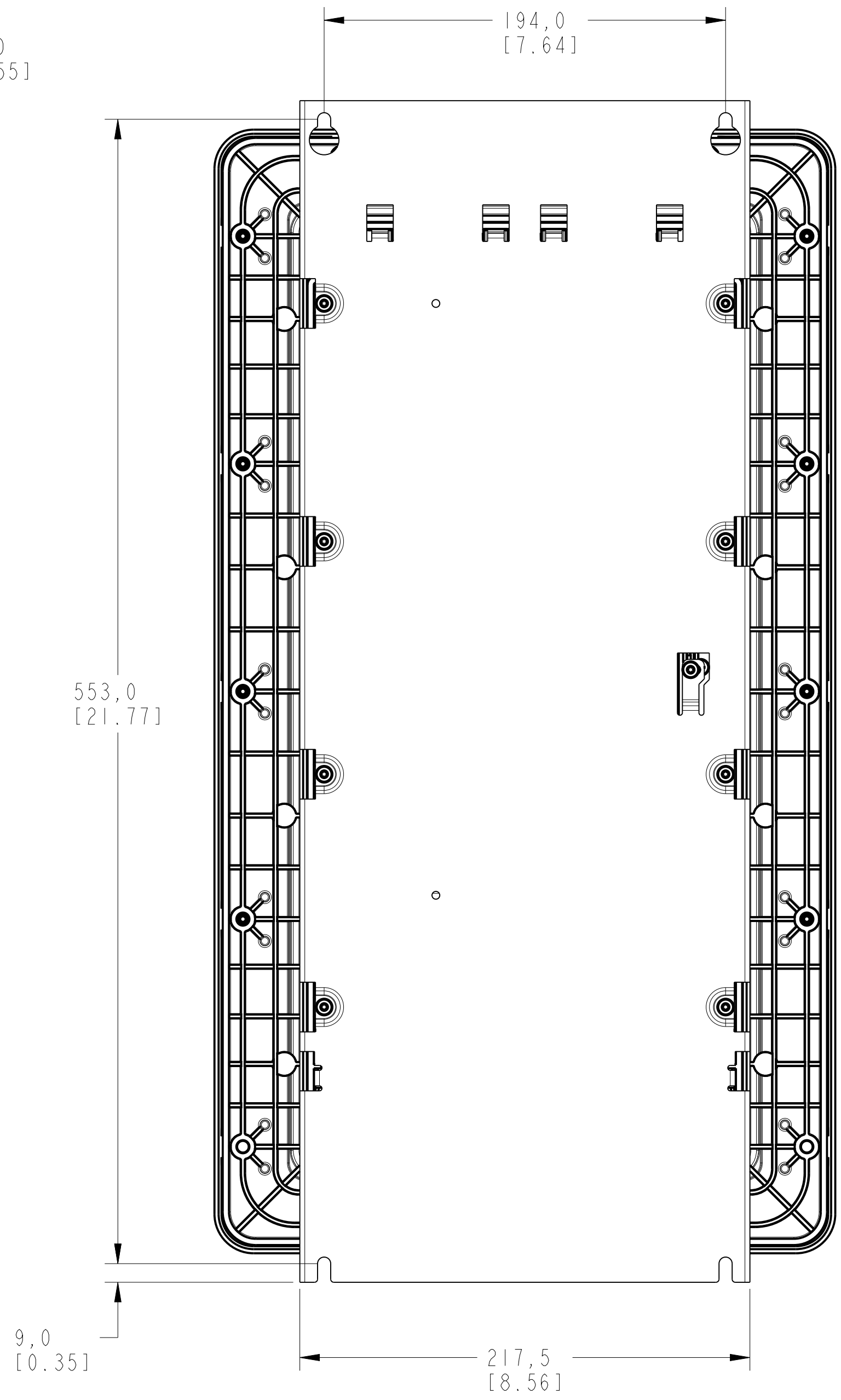
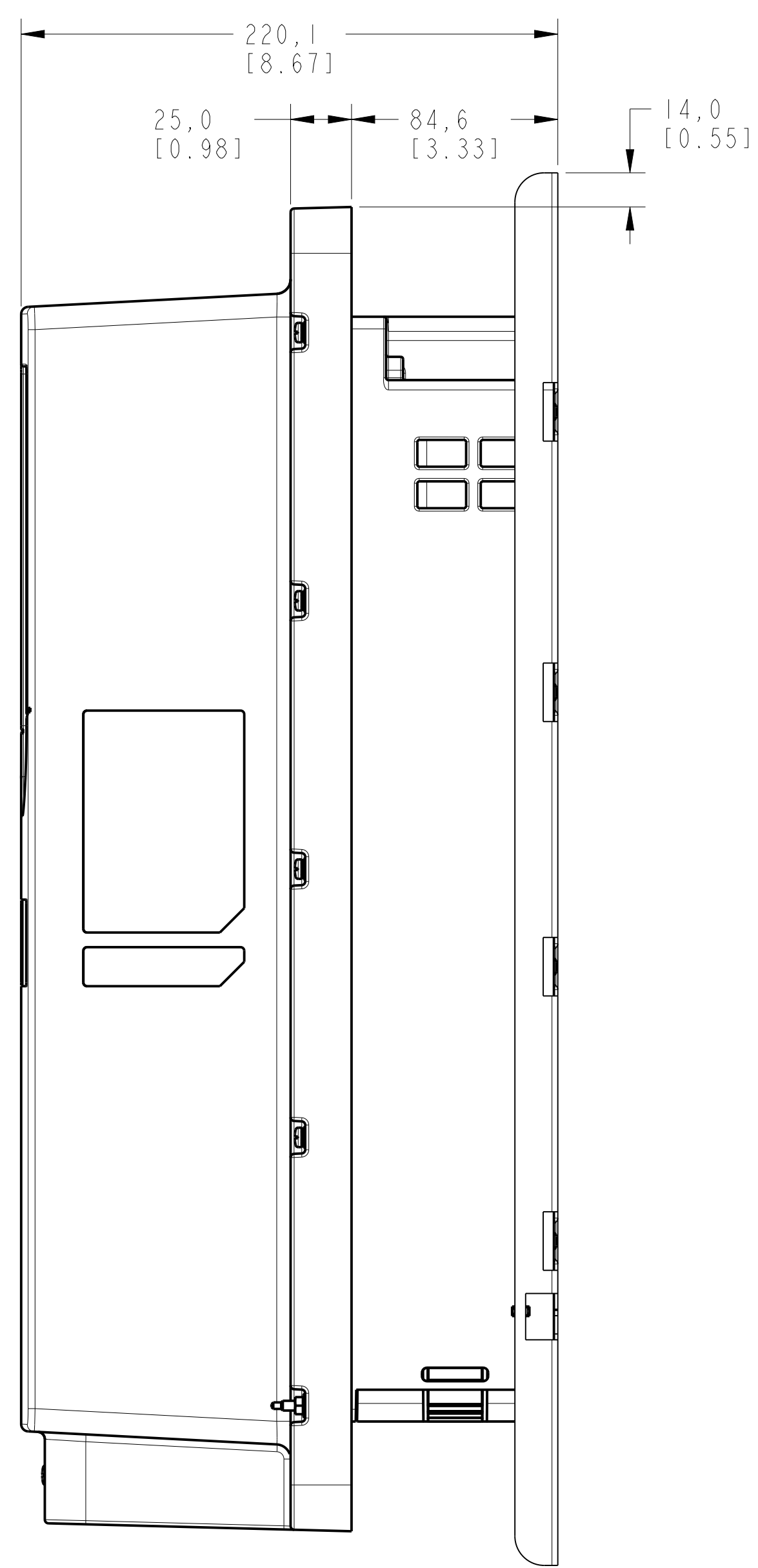
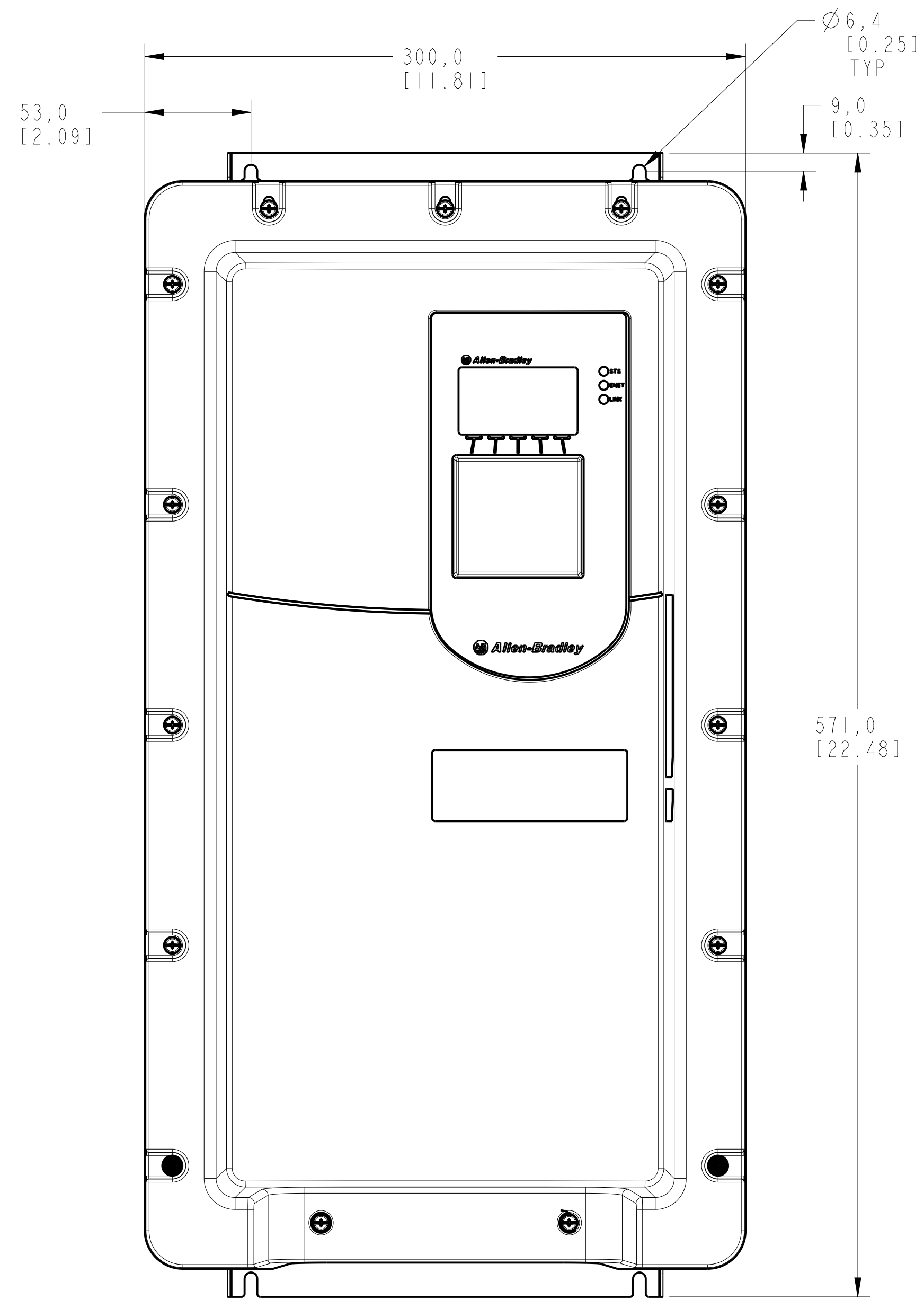

SCALE 0.500

NEMA/UL TYPE12

NEMA/UL TYPE12

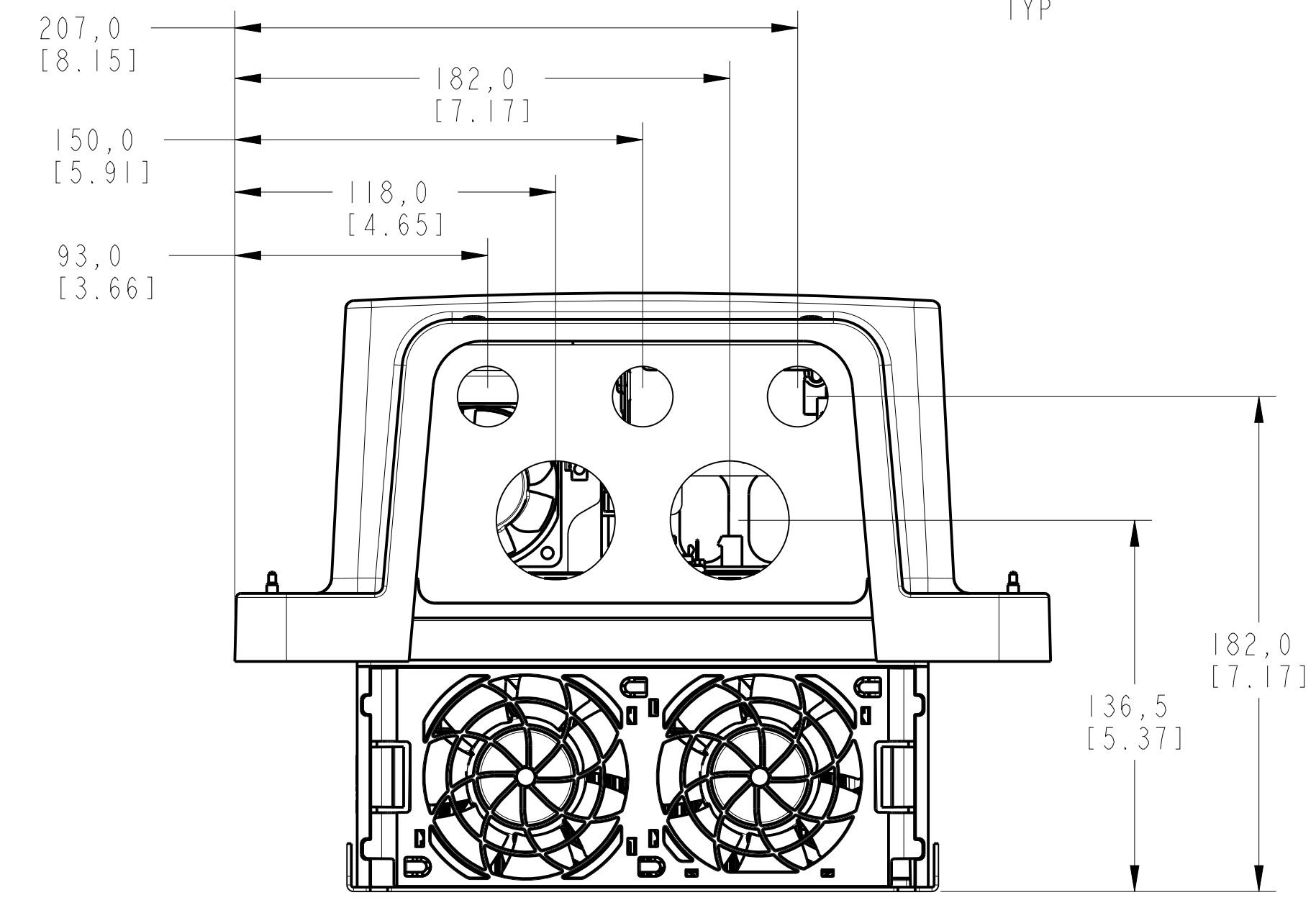

		<small>CONFIDENTIAL AND PROPRIETARY INFORMATION. THIS DOCUMENT CONTAINS CONFIDENTIAL AND PROPRIETARY INFORMATION OF ROCKWELL AUTOMATION, INC. AND MAY NOT BE USED, COPIED OR DISCLOSED TO OTHERS, EXCEPT WITH THE AUTHORIZED WRITTEN PERMISSION OF ROCKWELL AUTOMATION, INC.</small>	
		Sheet 3 Of 4	
DESCRIPTION STANDARD PF750-FRAME-4-TYPE12	SIZE D1R D	VER 396828-6	VER 06
DRAWN BY: XTAO1	DATE: 12-02-13		

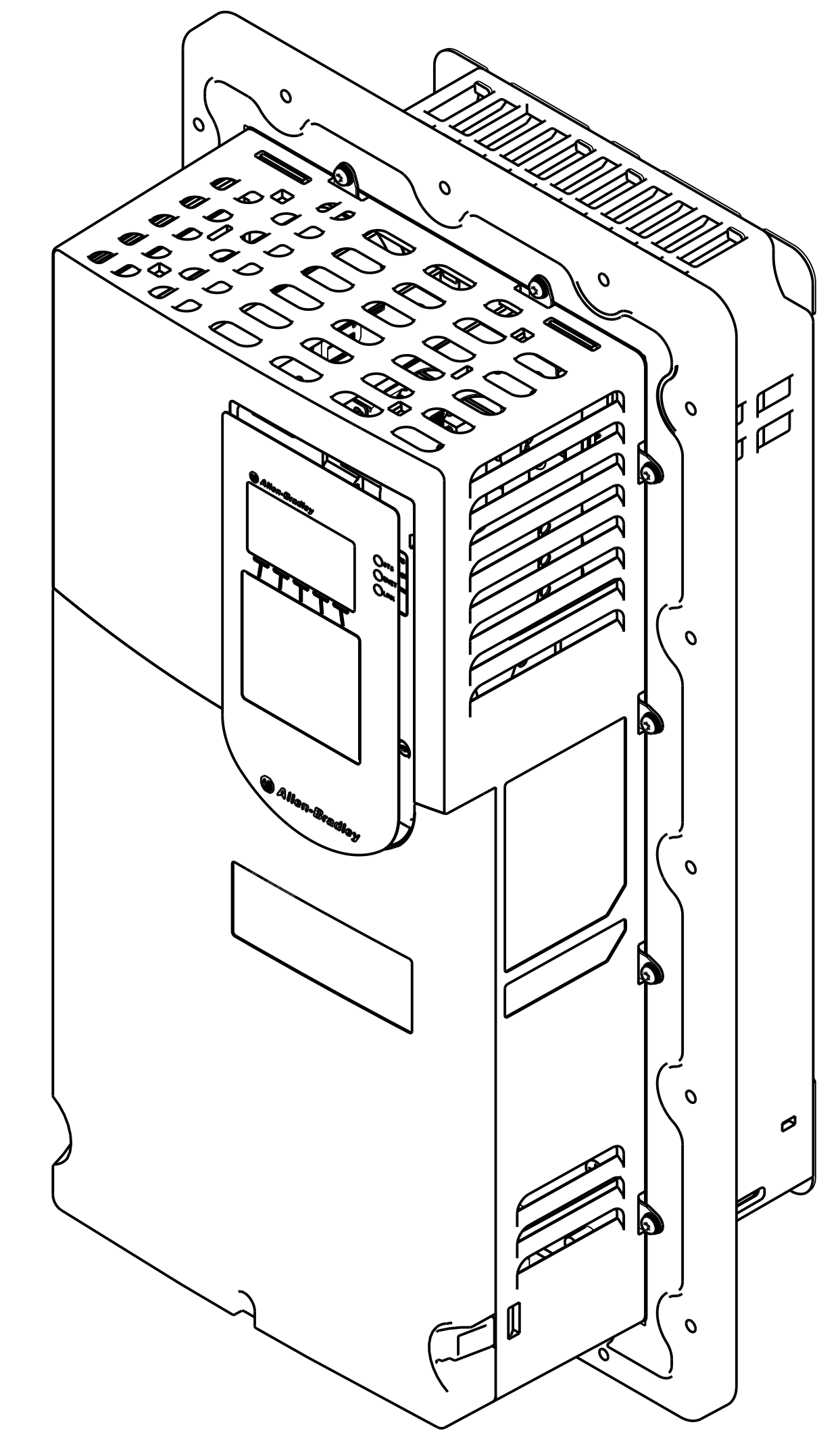
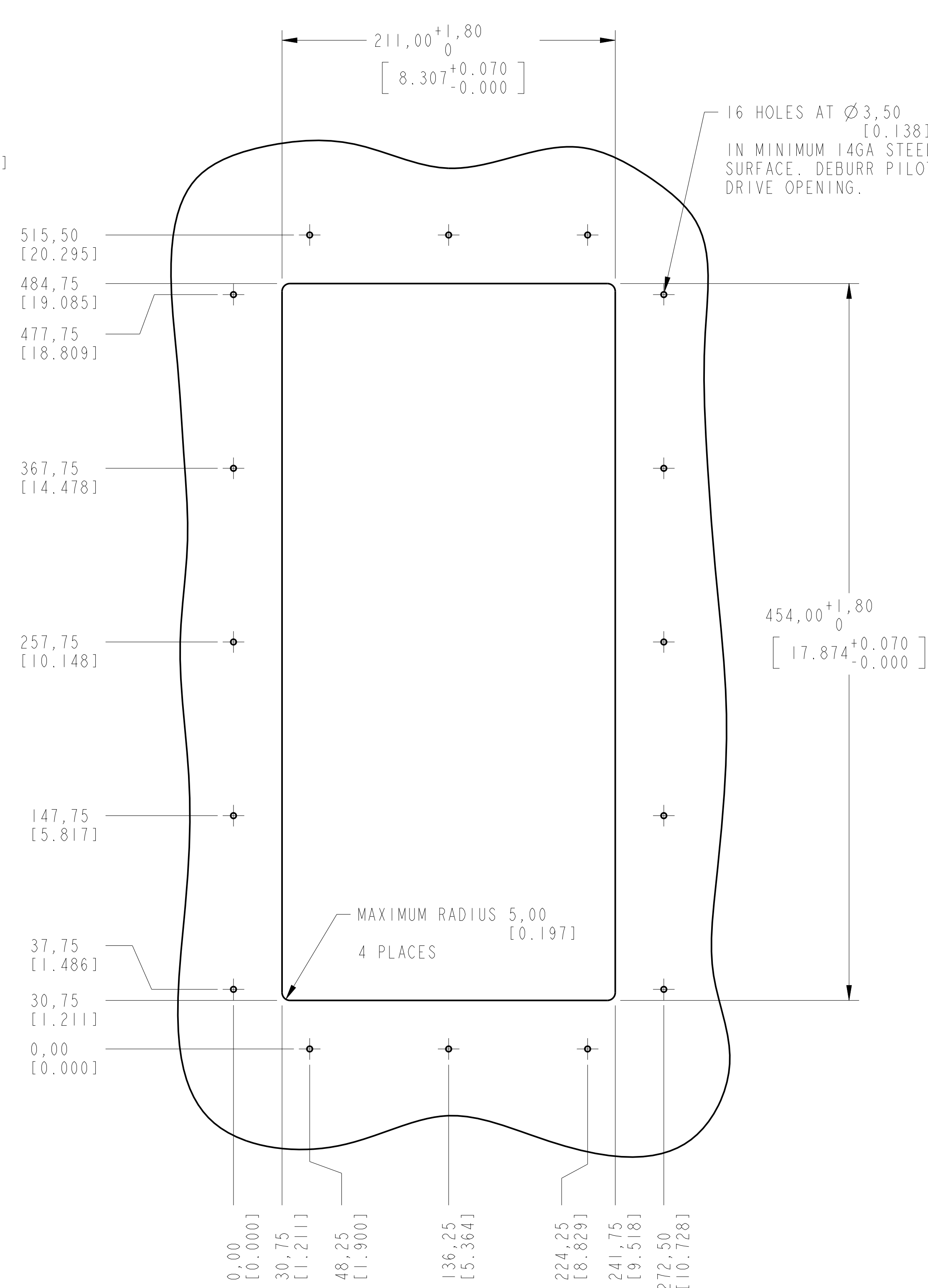
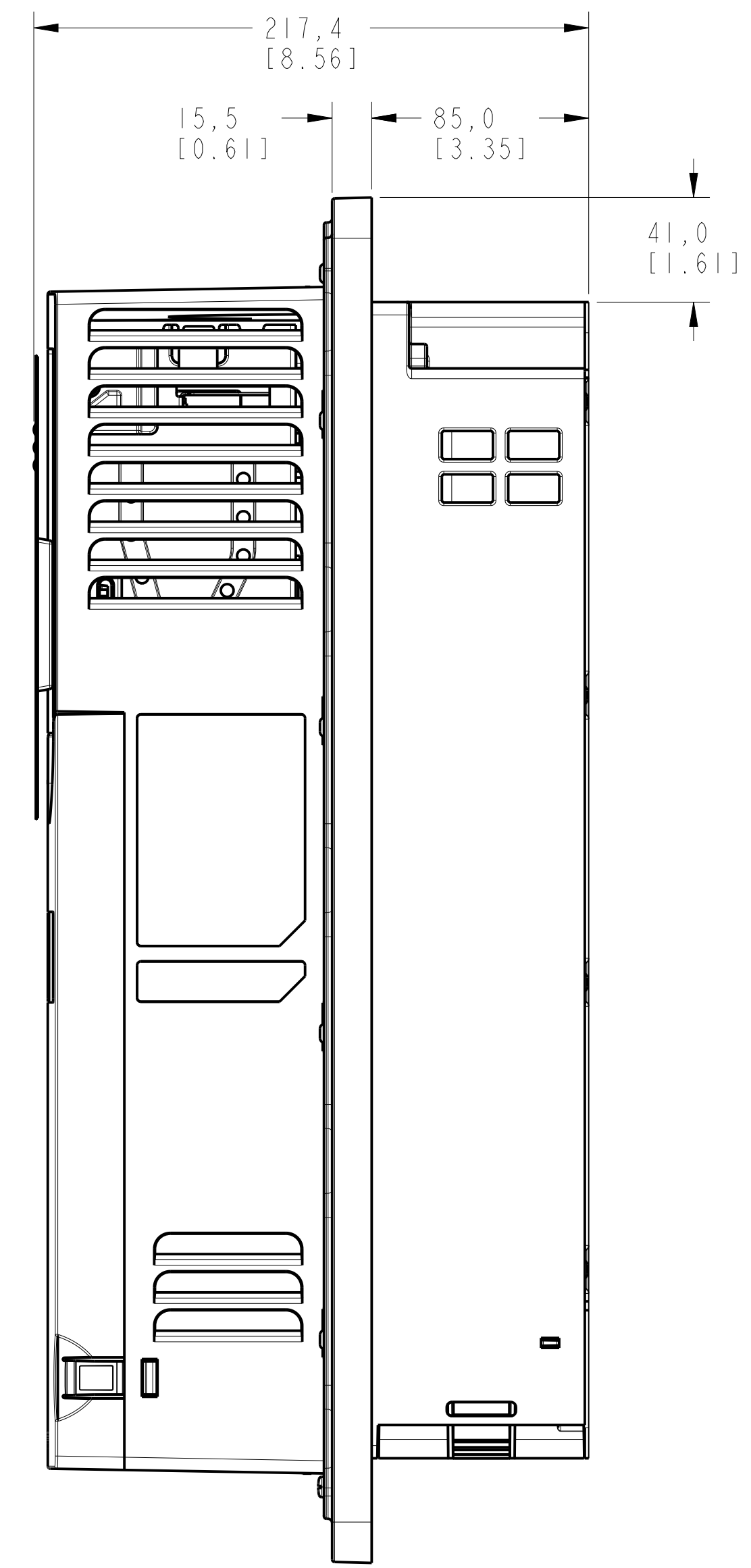
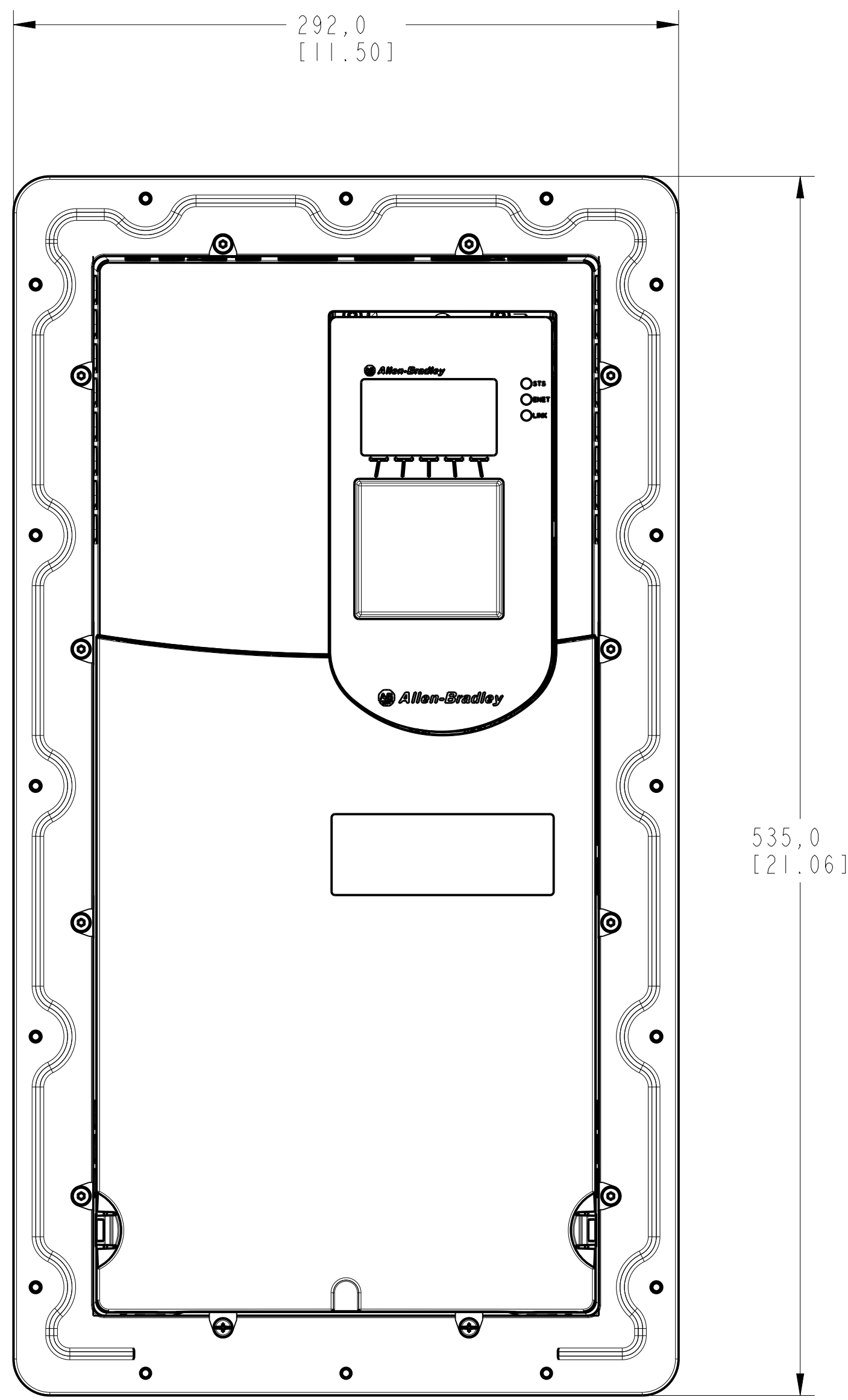

SCALE 0.500

TYPE 4X, FLANGE MOUNT

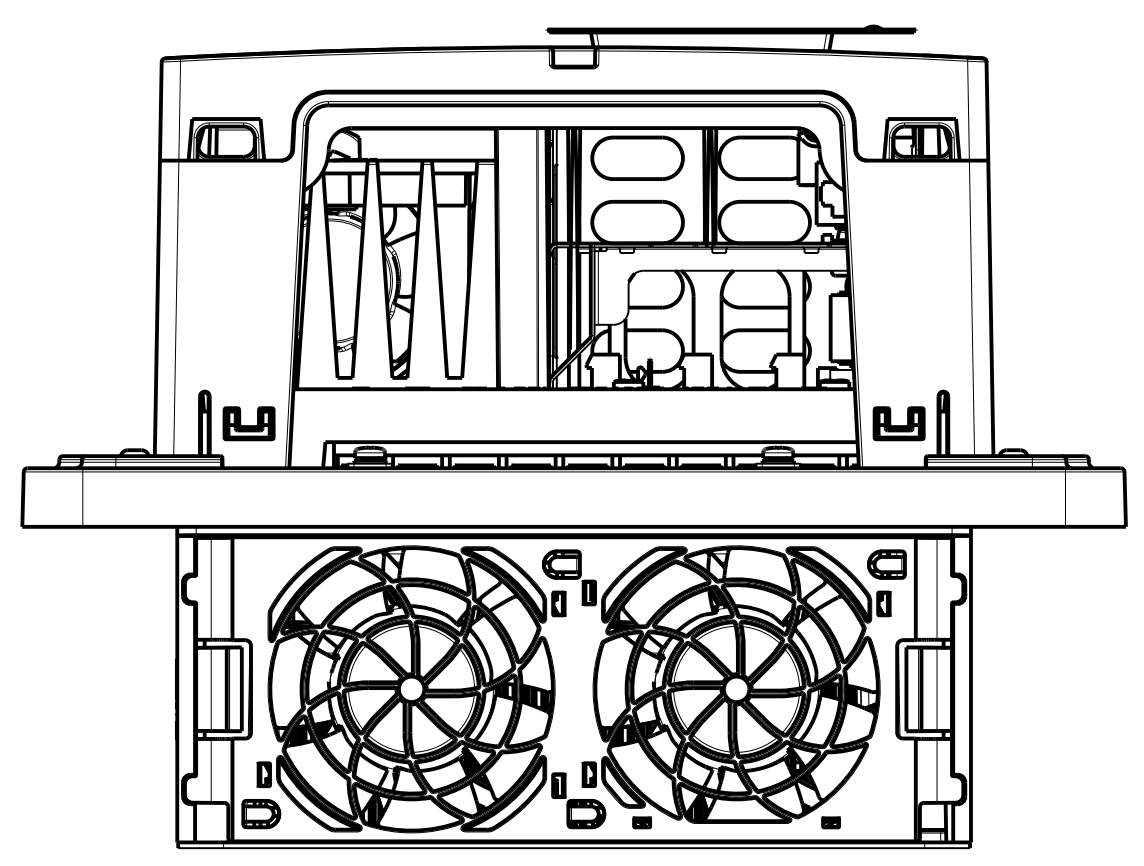

TYPE 4X, FLANGE MOUNT

SCALE 0.500

FLANGE MOUNT DRIVE PANEL CUTOUT

NOTE:
1. MOUNTING HARDWARE SHIPPED WITH FLANGE MOUNT DRIVE.

		<small>CONFIDENTIAL AND PROPRIETARY INFORMATION. THIS DOCUMENT CONTAINS CONFIDENTIAL AND PROPRIETARY INFORMATION OF ROCKWELL AUTOMATION, INC. AND MAY NOT BE USED, COPIED OR DISCLOSED TO OTHERS, EXCEPT WITH THE AUTHORIZED WRITTEN PERMISSION OF ROCKWELL AUTOMATION, INC.</small>	
		Sheet 4 of 4	
DESCRIPTION STANDARD PF750-FRAME-4-FLANGE MOUNT	SIZE D1R D	396828-6	VER 06
DRAWN BY: XTACI	DATE: 12-02-13		