

FRAME-STACKS	BRAKE OPTION	MOTOR DIMENSIONS		CATALOG STRING	APPROX MOTOR BODY WEIGHT KG [LBS]
		L	LC		
115-2	2	217,9 [8.58]	141,8 [5.58]	VPH-x1152x-xxx2xxx	12.8 [28.2]
	4	253,7 [9.99]	177,6 [6.99]	VPH-x1152x-xxx4xxx	15.1 [33.3]
115-3	2	243,3 [9.58]	167,2 [6.58]	VPH-x1153x-xxx2xxx	14.8 [32.6]
	4	279,1 [10.99]	203,0 [7.99]	VPH-x1153x-xxx4xxx	17.0 [37.5]

CABLE LENGTH OPTION	CABLE TYPE	CABLE LENGTH DIMENSION C	CATALOG STRING	APPROX CABLE WEIGHT KG [LBS]
03	FLEX	3000 [118.11] (3 METERS)	VPH-x115xx-xx0xx03 VPH-x115xx-xx1xx03	1.2 [2.6] 1.5 [3.3]
05	FLEX	5000 [196.85] (5 METERS)	VPH-x115xx-xx0xx05 VPH-x115xx-xx1xx05	1.6 [3.4] 2.5 [5.5]
07	FLEX	7000 [275.59] (7 METERS)	VPH-x115xx-xx0xx07 VPH-x115xx-xx1xx07	2.7 [6.0] 3.5 [7.7]
09	STANDARD	9000 [354.33] (9 METERS)	VPH-x115xx-xx0xx09 VPH-x115xx-xx1xx09	3.5 [7.7] 4.7 [10.3]
12	STANDARD	12000 [472.44] (12 METERS)	VPH-x115xx-xx0xx12 VPH-x115xx-xx1xx12	4.7 [10.2] 5.6 [12.3]
15	STANDARD	15000 [590.55] (15 METERS)	VPH-x115xx-xx0xx15 VPH-x115xx-xx1xx15	5.8 [12.8] 6.7 [14.8]

- NOTES:
- DXF OF THIS DRAWING MUST BE SCALED TO LENGTH. SEE MOTOR DIMENSIONS CHART.
 - 3D STEP (.stp) FILES ARE AVAILABLE FOR ALL MOTOR CONFIGURATIONS.
 - FOR ADDITIONAL SPECIFICATIONS SEE ESE DRAWING DIR 10004356352.
 - APPROX TOTAL MOTOR WEIGHT EQUALS MOTOR BODY WEIGHT PLUS CABLE WEIGHT (SEE CHARTS).
 - MOTOR OUTER BODY MATERIAL: 316 STAINLESS STEEL
 - VPH CATALOG STRING CODE:

BRAKE: 2 = NO BRAKE, 4 = BRAKE
CONNECTOR: 0 = FLYING LEADS, 1 = SINGLE SPEEDTEC DIN CONNECTOR
CABLE LENGTH: SEE CHART

TYPE OF BEND RADIUS	TYPE OF CABLE	MINIMUM BEND RADIUS
STATIC BEND RADIUS	STANDARD	119 [4.7]
	FLEX	
CONTINUOUS BEND RADIUS	FLEX	170 [6.7]

UNLESS OTHERWISE SPECIFIED, DO NOT SCALE DRAWING DIMENSIONS ARE IN MILLIMETERS WITH INCHES REFERENCED (X) UNLESS OTHERWISE REFERENCED. 3RD ANGLE PROJECTION

Rockwell Automation

VPH, F115, ESM

CONFIDENTIAL AND PROPRIETARY INFORMATION. THIS DOCUMENT CONTAINS CONFIDENTIAL AND PROPRIETARY INFORMATION OF ROCKWELL AUTOMATION, INC. AND MAY NOT BE USED, COPIED OR DISCLOSED TO OTHERS, EXCEPT WITH THE AUTHORIZED WRITTEN PERMISSION OF ROCKWELL AUTOMATION, INC.

SHEET 1 OF 2

SIZE D1R: D, 10003680112, VER: 00

DRAWN BY: SRGADDAM, DATE: DEC-06-2018

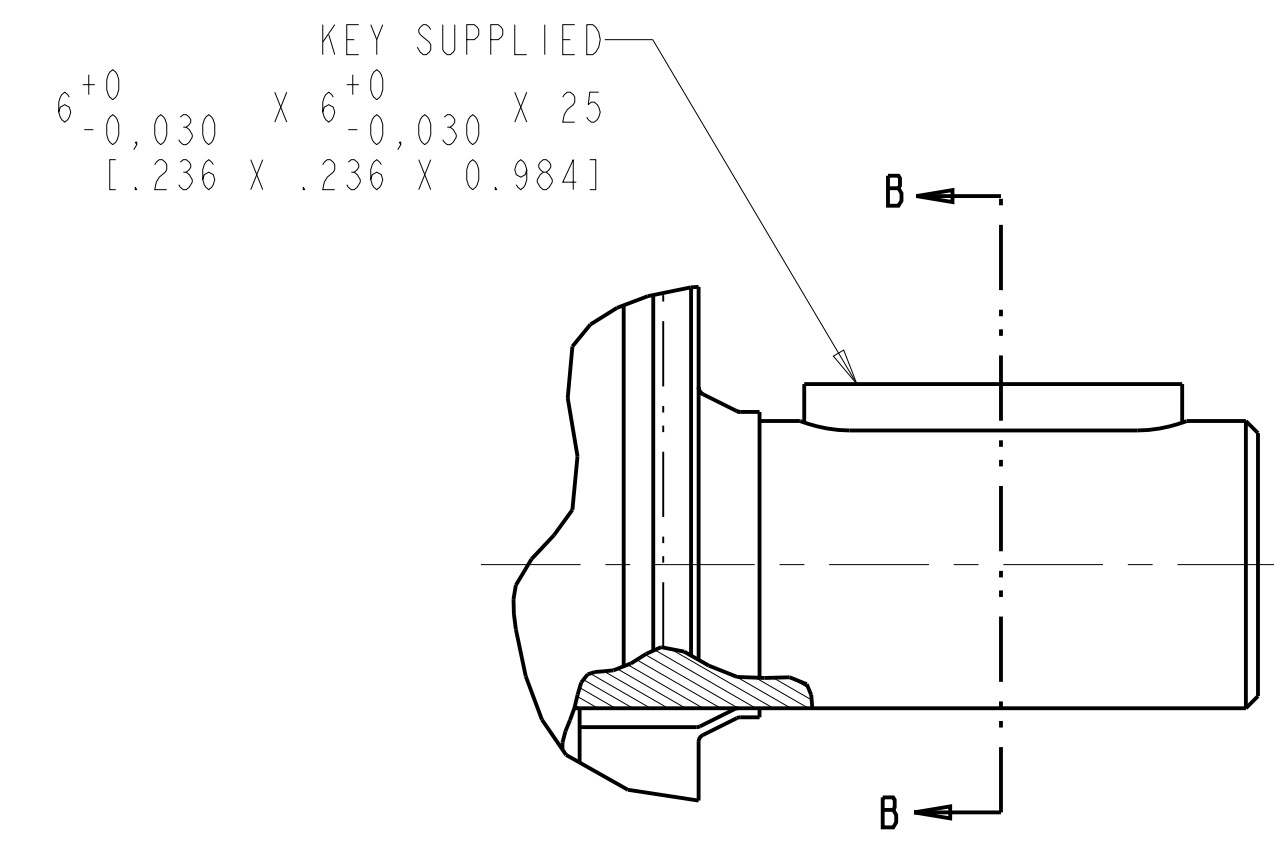
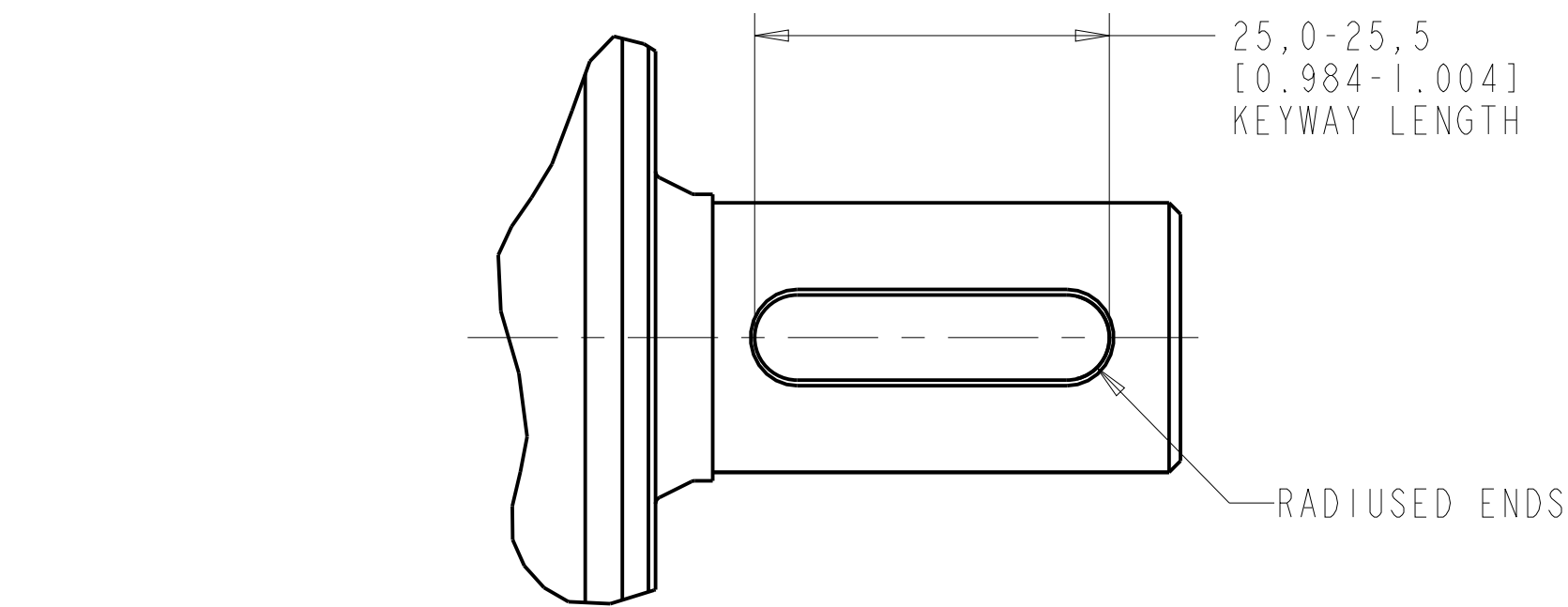

DETAIL B
SH 1, ZONE D6
SCALE 2.000

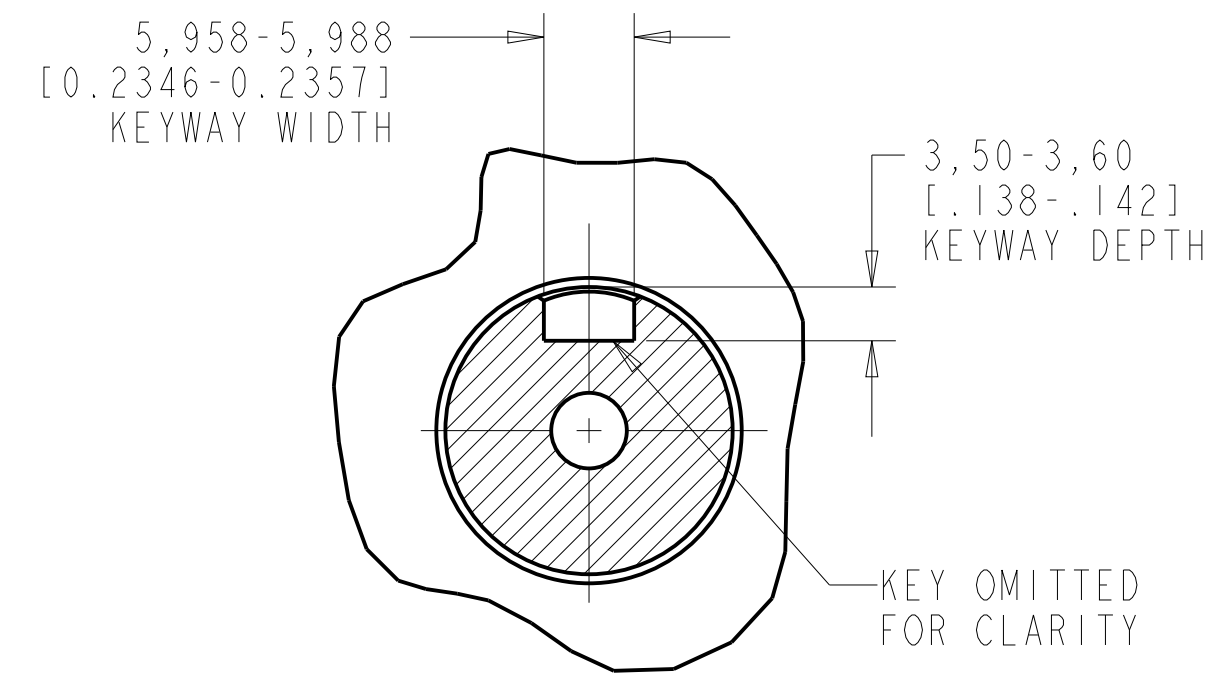

SECTION B-B

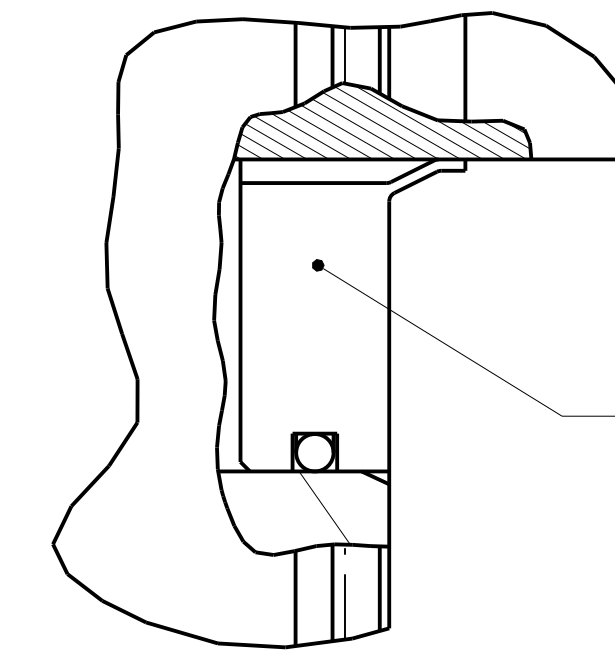

DETAIL A
SH 1, ZONE E5
SCALE 2.500

CONNECTOR OPTION "0"		
FLYING LEADS		
WIRE COLOR	AWG	FUNCTION
BROWN	14	U
BLACK	14	V
BLUE	14	W
GREEN/YELLOW	14	GND
BLUE	22	DSL +
BLACK	18	MBRK +
WHITE	18	MBRK -
WHITE/BLUE	22	DSL -
-	-	-
APPLICABLE CATALOG STRINGS		
VPH-x165xx-xx0xxxx		

CONNECTOR OPTION "1"	
M923 EXTENSION CONNECTOR	
PIN ID	FUNCTION
A	U
B	V
C	W
⊕	GND
E	DSL +
F	MBRK +
G	MBRK -
H	DSL -
L	-
APPLICABLE CATALOG STRINGS	
VPH-x165xx-xx1xxxx	

